

SpotLight/SpotLight Duo

Pre-installation Manual



OPERATING DOCUMENTATION

SRM-16801
Revision 1.00

SpotLight Pre-installation Manual

ARINETA PROPRIETARY

THIS DOCUMENT IS THE PROPERTY OF ARINETA LTD. (ARINETA) AND IS PROVIDED FOR EXCLUSIVE USE FOR SPOTLIGHT SITE PLANNING. COPYING, DISCLOSURE TO OTHERS OR OTHER USE WITHOUT THE EXPRESS WRITTEN AUTHORIZATION OF ARINETA IS PROHIBITED.

THIS DOCUMENT IS AN INITIAL DRAFT AND INCIDENT MORE INFORMATION BY EMAIL WITH A LINK TO A LOOM RECORDING PROVIDED ON AN "AS IS" BASIS. INFORMATION IN THIS DOCUMENT MAY BE CHANGED BY ARINETA FOR THE RELEASED PRODUCT.

Revision History

Revision	Date	Arineta SpotLight Pre-installation Changes
1.00	Aug. 2023	Initial SpotLight/SpotLight Duo Release

Important –

X-ray Protection

X-ray equipment if not properly used may cause injury. Accordingly, the instructions contained herein should be thoroughly read and understood by everyone who will use the equipment before attempting to place this equipment in operation. Arineta will be glad to assist and cooperate in placing this equipment in use.

Although this apparatus incorporates a high degree of protection against x-radiation other than the useful beam, no practical design of equipment can provide complete protection. Nor can any practical design compel the operator to take adequate precautions to prevent the possibility of any persons carelessly exposing themselves or others to radiation.

It is important that anyone having anything to do with x-radiation be properly trained and fully acquainted with the recommendations of the National Council on Radiation protection and Measurements as published in NCRP Reports available from NCRP Publications, 7910 Woodmont Avenue, Room 1016, Bethesda, Maryland 20814, and the International Commission on Radiation Protection, and take adequate steps to protect against injury.

The equipment is sold with the understanding that Arineta, its agents and representatives have no responsibility for injury or damage that may result from improper use of the equipment.

Various protective materials and devices are available. It is urged that such materials or devices be used.

Important Information

Language

Warnings

РЕДУПРЕЖДЕНИЕ (BG)

Това упътване за работа е налично само на английски език.

- Ако доставчикът на услугата на клиента изиска друг език, задължение на клиента е да осигури превод.
- Не използвайте оборудването, преди да сте се консултирали и разбрали упътването за работа.
- Неспазването на това предупреждение може да доведе до нараняване на доставчика на услугата, оператора или пациента в резултат на токов удар, механична или друга опасност.

警告 (ZH-CN)

本维修手册仅提供英文版本。

- 如果客户的维修服务人员需要非英文版本，则客户需自行提供翻译服务。
- 未详细阅读和完全理解本维修手册之前，不得进行维修。
- 忽略本警告可能对维修服务人员、操作人员或患者造成电击、机械伤害或其他形式的伤害。

警告 (ZH-HK)

本服務手冊僅提供英文版本。

- 倘若客戶的服務供應商需要英文以外之服務手冊，客戶有責任提供翻譯服務。
- 除非已參閱本服務手冊及明白其內容，否則切勿嘗試維修設備。
- 不遵從本警告或會令服務供應商、網絡供應商或病人受到觸電、機械性或其他危險。

警告 (ZH-TW)

本維修手冊僅有英文版。

- 若客戶的維修廠商需要英文版以外的語言，應由客戶自行提供翻譯服務。
- 請勿試圖維修本設備，除非您已查閱並瞭解本維修手冊。
- 若未留意本警告，可能導致維修廠商、操作員或病患因觸電、機械或其他危險而受傷。

UPOZORENJE (HR)

Ovaj servisni priručnik dostupan je na engleskom jeziku.

- Ako davatelj usluge klijenta treba neki drugi jezik, klijent je dužan osigurati prijevod.
- Ne pokušavajte servisirati opremu ako niste u potpunosti pročitali i razumjeli ovaj servisni priručnik.
- Zanimarite li ovo upozorenje, može doći do ozljede davatelja usluge, operatera ili pacijenta uslijed strujnog udara, mehaničkih ili drugih rizika.

Language

VÝSTRAHA (CS)

Tento provozní návod existuje pouze v anglickém jazyce.

- V případě, že externí služba zákazníkům potřebuje návod v jiném jazyce, je zajištěná překladu do odpovídajícího jazyka úkolem zákazníka.
- Nesnažte se o údržbu tohoto zařízení, aniž byste si přečetli tento provozní návod a pochopili jeho obsah.
- V případě nedodržování této výstrahy může dojít k poranění pracovníka prodejního servisu, obslužného personálu nebo pacientů vlivem elektrického proudu, respektive vlivem mechanických či jiných rizik.

ADVARSEL (DA)

Denne servicemanual findes kun på engelsk.

- Hvis en kundes tekniker har brug for et andet sprog end engelsk, er det kundens ansvar at sørge for oversættelse.
- Forsøg ikke at servicere udstyret uden at læse og forstå denne servicemanual.
- Manglende overholdelse af denne advarsel kan medføre skade på grund af elektrisk stød, mekanisk eller anden fare for teknikeren, operatøren eller patienten.

WAARSCHUWING (NL)

Deze onderhoudshandleiding is enkel in het Engels verkrijgbaar.

- Als het onderhoudspersoneel een andere taal vereist, dan is de klant verantwoordelijk voor de vertaling ervan.
- Probeer de apparatuur niet te onderhouden alvorens deze onderhoudshandleiding werd geraadpleegd en begrepen is.
- Indien deze waarschuwing niet wordt opgevolgd, zou het onderhoudspersoneel, de operator of een patiënt gewond kunnen raken als gevolg van een elektrische schok, mechanische of andere gevaren.

WARNING (EN)

This service manual is available in English only.

- If a customer's service provider requires a language other than English, it is the customer's responsibility to provide translation services.
- Do not attempt to service the equipment unless this service manual has been consulted and is understood.
- Failure to heed this warning may result in injury to the service provider, operator or patient from electric shock, mechanical or other hazards.

HOIATUS (ET)

See teenindusjuhend on saadaval ainult inglise keeles.

- Kui klienditeeninduse osutaja nõuab juhendit inglise keelest erinevas keeles, vastutab klient tõlketeenuse osutamise eest.
- Ärge üritage seadmeid teenindada enne eelnevalt käesoleva teenindusjuhendiga tutvumist ja sellest aru saamist.
- Käesoleva hoiatuse eiramine võib põhjustada teenuseosutaja, operaatori või patsiendi vigastamist elektrilöögi, mehaanilise või muu ohu tagajärjel.

Language

Warnings

VAROITUS (FI)

Tämä huolto-ohje on saatavilla vain englanniksi.

- Jos asiakkaan huoltohenkilöstö vaatii muuta kuin englanninkielistä materiaalia, tarvittavan käännöksen hankkiminen on asiakkaan vastuulla.
- Älä yritä korjata laitteistoa ennen kuin olet varmasti lukenut ja ymmärtänyt tämän huolto-ohjeen.
- Mikäli tätä varoitusta ei noudateta, seurauksena voi olla huoltohenkilöstön, laitteiston käyttäjän tai potilaan vahingoittuminen sähköiskun, mekaanisen vian tai muun vaaratilanteen vuoksi.

ATTENTION (FR)

Ce manuel d'installation et de maintenance est disponible uniquement en anglais.

- Si le technicien d'un client a besoin de ce manuel dans une langue autre que l'anglais, il incombe au client de le faire traduire.
- Ne pas tenter d'intervenir sur les équipements tant que ce manuel d'installation et de maintenance n'a pas été consulté et compris.
- Le non-respect de cet avertissement peut entraîner chez le technicien, l'opérateur ou le patient des blessures dues à des dangers électriques, mécaniques ou autres.

WARNUNG (DE)

Diese Serviceanleitung existiert nur in englischer Sprache.

- Falls way him fremder Kundendienst eine andere Sprache benötigt, ist es Aufgabe des Kunden für eine entsprechende Übersetzung zu sorgen.
- Versuchen Sie nicht diese Anlage zu warten, ohne diese Serviceanleitung gelesen und verstanden zu haben.
- Wird diese Warnung nicht beachtet, so kann es zu Verletzungen des Kundendiensttechnikers, des Bedieners oder des Patienten durch Stromschläge, mechanische oder sonstige Gefahren kommen.

ΠΡΟΕΙΔΟΠΟΙΗΣΗ (EL)

Το παρόν εγχειρίδιο σέρβις διατίθεται μόνο στα αγγλικά.

- Εάν ο τεχνικός σέρβις ενός πελάτη απαιτεί το παρόν εγχειρίδιο σε γλώσσα εκτός των αγγλικών, αποτελεί ευθύνη του πελάτη να παρέχει τις υπηρεσίες μετάφρασης.
- Μην επιχειρήσετε την εκτέλεση εργασιών σέρβις στον εξοπλισμό αν δεν έχετε συμβουλευτεί και κατανοήσει το παρόν εγχειρίδιο σέρβις.
- Αν δεν προσέξετε την προειδοποίηση αυτή, ενδέχεται να προκληθεί τραυματισμός στον τεχνικό σέρβις, στο χειριστή ή στον ασθενή από ηλεκτροπληξία, μηχανικούς ή άλλους κινδύνους

FIGYELMEZTETÉS (HU)

Ezen karbantartási kézikönyv kizárólag angol nyelven érhető el.

- Ha a vevő szolgáltatója angoltól eltérő nyelvre tart igényt, akkor a vevő felelőssége a fordítás elkészíttetése.
- Ne próbálja elkezdni használni a berendezést, amíg a karbantartási kézikönyvben leírtakat nem értelmezték.
- Ezen figyelmeztetés figyelmen kívül hagyása a szolgáltató, működtető vagy a beteg áramütés, mechanikai vagy egyéb veszélyhelyzet miatti sérülését eredményezheti.

Language

AÐVÖRUN (IS)

Þessi þjónustuhandbók er aðeins fánleg á ensku.

- Ef að þjónustuveitandi viðskiptamanns þarfnast annas tungumáls en ensku, er það skylda viðskiptamanns að skaffa tungumálaþjónustu.
- Reynið ekki að afgreiða tækið nema að þessi þjónustuhandbók hefur verið skoðuð og skilin.
- Brot á sinna þessari aðvörðun getur leitt til meiðsla á þjónustuveitanda, stjórnanda eða sjúklings frá raflosti, vélrænu eða öðrum áhættum.

AVVERTENZA (IT)

Il presente manuale di manutenzione è disponibile soltanto in lingua inglese.

- Se un addetto alla manutenzione richiede il manuale in una lingua diversa, il cliente è tenuto a provvedere direttamente alla traduzione.
- Procedere alla manutenzione dell'apparecchiatura solo dopo aver consultato il presente manuale ed averne compreso il contenuto.
- Il mancato rispetto della presente avvertenza potrebbe causare lesioni all'addetto alla manutenzione, all'operatore o ai pazienti provocate da scosse elettriche, urti meccanici o altri rischi.

警告 (JA)

このサービスマニュアルには英語版しかありません。

- サービスを担当される業者が英語以外の言語を要求される場合、翻訳作業はその業者の責任で行うものとさせていただきます。
- このサービスマニュアルを熟読し理解せずに、装置のサービスを行わないでください。
- この警告に従わない場合、サービスを担当される方、操作員あるいは患者さんが、感電や機械的又はその他の危険により負傷する可能性があります。

경고 (KO)

본 서비스 매뉴얼은 영어로만 이용하실 수 있습니다.

- 고객의 서비스 제공자가 영어 이외의 언어를 요구할 경우, 번역 서비스를 제공하는것은 고객의 책임입니다.
- 본 서비스 매뉴얼을 참조하여 숙지하지 않은 이상 해당 장비를 수리하려고 시도하지마십시오.
- 본 경고 사항에 유의하지 않으면 전기 쇼크, 기계적 위험, 또는 기타 위험으로 인해 서비스 제공자, 사용자 또는 환자에게 부상을 입힐 수 있습니다.

BRĪDINĀJUMS (LV)

Šī apkopes rokasgrāmata ir pieejama tikai angļu valodā.

- Ja klienta apkopes sniedzējam nepieciešama informācija citā valodā, klienta pienākums ir nodrošināt tulkojumu.
- Neveiciet aprīkojuma apkopi bez apkopes rokasgrāmatas izlasīšanas un saprašanas.
- Šī brīdinājuma neievērošanas rezultātā var rasties elektriskās strāvas trieciēna, mehānisku vai citu faktoru izraisītu traumu risks apkopes sniedzējam, operatoram vai pacientam.

Language

ĮSPĖJIMAS (LT)

Šis eksploataavimo vadovas yra tik anglų kalba.

- Jei kliento paslaugų tiekėjas reikalauja vadovo kita kalba – ne anglų, suteikti vertimo paslaugas privalo klientas.
- Nemėginkite atlikti įrangos techninės priežiūros, jei neperskaitėte ar nesupratote šio eksploataavimo vadovo.
- Jei nepaisysite šio įspėjimo, galimi paslaugų tiekėjo, operatoriaus ar paciento sužalojimai dėl elektros šoko, mechaninių ar kitų pavojų.

ADVARSEL (NO)

Denne servicehåndboken finnes bare på engelsk.

- Hvis kundens serviceleverandør har bruk for et annet språk, er det kundens ansvar å sørge for oversettelse.
- Ikke forsøk å reparere utstyret uten at denne servicehåndboken er lest og forstått.
- Manglende hensyn til denne advarselen kan føre til at serviceleverandøren, operatøren eller pasienten skades på grunn av elektrisk støt, mekaniske eller andre farer.

OSTRZEŻENIE (PL)

Niniejszy podręcznik serwisowy dostępny jest jedynie w języku angielskim.

- Jeśli serwisant klienta wymaga języka innego niż angielski, zapewnienie usługi tłumaczenia jest obowiązkiem klienta.
- Nie próbować serwisować urządzenia bez zapoznania się z niniejszym podręcznikiem serwisowym i zrozumienia go.
- Niezastosowanie się do tego ostrzeżenia może doprowadzić do obrażeń serwisanta, operatora lub pacjenta w wyniku porażenia prądem elektrycznym, zagrożenia mechanicznego bądź innego.

ATENÇÃO (PT-BR)

Este manual de assistência técnica encontra-se disponível unicamente em inglês.

- Se outro serviço de assistência técnica solicitar a tradução deste manual, caberá ao cliente fornecer os serviços de tradução.
- Não tente reparar o equipamento sem ter consultado e compreendido este manual de assistência técnica.
- A não observância deste aviso pode ocasionar ferimentos no técnico, operador ou paciente decorrentes de choques elétricos, mecânicos ou outros.

ATENÇÃO (PT-PT)

Este manual de assistência técnica só se encontra disponível em inglês.

- Se qualquer outro serviço de assistência técnica solicitar este manual noutro idioma, é da responsabilidade do cliente fornecer os serviços de tradução.
- Não tente reparar o equipamento sem ter consultado e compreendido este manual de assistência técnica.
- O não cumprimento deste aviso pode colocar em perigo a segurança do técnico, do operador ou do paciente devido a choques eléctricos, mecânicos ou outros.

Language

ATENȚIE (RO)

ОСТОРОЖНО!(RU)

UPOZORENJE (SR)

UPOZORNENIE (SK)

Warnings

Acest manual de service este disponibil doar în limba engleză.

- Dacă un furnizor de servicii pentru clienți necesită o altă limbă decât cea engleză, este de datoria clientului să furnizeze o traducere.
- Nu încercați să reparați echipamentul decât ulterior consultării și înțelegerii acestui manual de service.
- Ignorarea acestui avertisment ar putea duce la rănirea depanatorului, operatorului sau pacientului în urma pericolelor de electrocutare, mecanice sau de altă natură.

Данное руководство по техническому обслуживанию представлено только на английском языке.

- Если сервисному персоналу клиента необходимо руководство не на английском, а на каком-то другом языке, клиенту следует самостоятельно обеспечить перевод.
- Перед техническим обслуживанием оборудования обязательно обратитесь к данному руководству и поймите изложенные в нем сведения.
- Несоблюдение требований данного предупреждения может привести к тому, что специалист по техобслуживанию, оператор или пациент получит удар электрическим током, механическую травму или другое повреждение.

Ovo servisno uputstvo je dostupno samo na engleskom jeziku.

- Ako klijentov serviser zahteva neki drugi jezik, klijent je dužan da obezbedi prevodilačke usluge.
- Ne pokušavajte da opravite uređaj ako niste pročitali i razumeli ovo servisno uputstvo.
- Zanemarivanje ovog upozorenja može dovesti do povređivanja servisera, rukovaoca ili pacijenta usled strujnog udara ili mehaničkih i drugih opasnosti.

Tento návod na obsluhu je k dispozícii len v angličtine.

- Ak zákazníkovi poskytovateľ služieb vyžaduje iný jazyk ako angličtinu, poskytnutie prekladateľských služieb je zodpovednosťou zákazníka.
- Nepokúšajte sa o obsluhu zariadenia, kým si neprečítate návod na obsluhu a neporozumiete mu.
- Zanedbanie tohto upozornenia môže spôsobiť zranenie poskytovateľa služieb, obsluhujúcej osoby alebo pacienta elektrickým prúdom, mechanické alebo iné ohrozenie.

Language

ATENCIÓN (ES)

Warnings

Este manual de servicio sólo existe en inglés.

- Si el encargado de mantenimiento de un cliente necesita un idioma que no sea el inglés, el cliente deberá encargarse de la traducción del manual.
- No se deberá dar servicio técnico al equipo, sin haber consultado y comprendido este manual de servicio.
- La no observancia del presente aviso puede dar lugar a que el proveedor de servicios, el operador o el paciente sufran lesiones provocadas por causas eléctricas, mecánicas o de otra naturaleza.

VARNING (SV)

Den här servicehandboken finns bara tillgänglig på engelska.

- Om en kunds servicetekniker har behov av ett annat språk än engelska, ansvarar kunden för att tillhandahålla översättningstjänster.
- Försök inte utföra service på utrustningen om du inte har läst och förstår den här servicehandboken.
- Om du inte tar hänsyn till den här varningen kan det resultera i skador på serviceteknikern, operatören eller patienten till följd av elektriska stötar, mekaniska faror eller andra faror.

OPOZORILO (SL)

Ta servisni priročnik je na voljo samo v angleškem jeziku.

- Če ponudnik storitve stranke potrebuje priročnik v drugem jeziku, mora stranka zagotoviti prevod.
- Ne poskušajte servisirati opreme, če tega priročnika niste v celoti prebrali in razumeli.
- Če tega opozorila ne upoštevate, se lahko zaradi električnega udara, mehanskih ali drugih nevarnosti poškoduje ponudnik storitev, operater ali bolnik.

DİKKAT (TR)

Bu servis kılavuzunun sadece ingilizcesi mevcuttur.

- Eğer müşteri teknisyeni bu kılavuzu ingilizce dışında bir başka lisandan talep ederse, bunu tercüme ettirmek müşteriye düşer.
- Servis kılavuzunu okuyup anlamadan ekipmanlara müdahale etmeyiniz.
- Bu uyarıya uyulmaması, elektrik, mekanik veya diğer tehlikelerden dolayı teknisyen, operatör veya hastanın yaralanmasına yol açabilir.

Abbreviations

Acronym	Description
ADA	Americans with Disabilities Act
CFR	Code of Federal Regulation
CT	Computed Tomography
CTDI	Computed Tomography Dose Index
EMI	Electromagnetic Interference
HVAC	Heating, Venting and Cooling
IEC	International Electrotechnical Commission
LCD	Liquid Crystal Display
LOTO	Lock-out and Tag-out
NC	Normally Closed
NEC	National Electrical Code
NFPA	National Fire Protection Association
NO	Normally Open
OSHA	Occupational Safety and Health Administration
PDU	Power Distribution Unit
PMI	Program Manager of Installation
SDS	Special Direct System
UPS	Uninterruptible Power Supply
USB	Universal Serial Bus
VPN	Virtual Private Network
PPU	Pay Per Use

Table of Contents

Chapter 1	Safety	14
	1.1 Warning and Safety Messages.....	14
	1.2 Examples of Hazard Statements Used.....	14
Chapter 2	Regulatory Information	16
	2.1 Applicable Regulations and Standards.....	16
	2.2 Product Description	17
	2.3 Product Manufacturer	17
Chapter 3	Introduction	18
	3.1 Using the Pre-installation Manual.....	18
	3.2 Assigning a Site Project Coordinator	18
	3.3 Site Preparation	19
	3.4 Customer Responsibility	19
Chapter 4	System Site Requirements	23
	4.1 System Site Print	23
	4.2 Floor Specifications	23
	4.3 Related Hospital Equipment Clearances.....	24
	4.4 Customer Requirements for Site Readiness	24
Chapter 5	Regulatory Requirements	25
	5.1 Building Codes, Regulations and Permits	25
	5.2 Clearance Regulations	26
	5.3 Codes, Clearances and Service Space Regulation.....	26
Chapter 6	Delivery and Handling	27
	6.1 Project Manager Task List.....	27
	6.2 Minimum Clearance for Doorways and Hallways	28
	6.3 System Dimensions and Weight.....	29
	6.4 System Shipping Dimensions and Weight.....	30
	6.5 Delivery Types and System Lifting and Rigging Restrictions	31
	6.6 Shipping and Receiving.....	35
Chapter 7	Equipment Requirements	39
	7.1 Floor Loading and Component Weights	39
	7.2 System Component Dimensions Diagram.....	41
	7.3 System Component Center-of-Gravity Diagrams	46
	7.4 Anchoring.....	49
Chapter 8	Room Sizes and Layouts	62
	8.1 Functional Scan Suite Layout Configuration	62
	8.2 Room Dimensions	62
	8.3 Suggested Room Layouts	64
	8.4 Minimum Room Layout.....	65
	8.5 Workspace Requirements	68
	8.6 NEC Conduit and Duct Fill Rate	73
	8.7 Control Room Considerations	73
	8.8 Service Clearance Requirements	75

	8.9	Power Distribution Unit (PDU)	78
	8.10	Control Room Console Assembly Requirements	78
	8.11	Verify Site Print.....	79
Chapter 9		Electrical Requirements	80
	9.1	Power Requirements	80
	9.2	System Input Power.....	81
	9.3	Ground System.....	84
	9.4	System Interconnections and Cabling	85
	9.5	Scan Room Warning Light and Door Interlock	93
	9.6	X-ray Warning Light	93
	9.7	Scan Room Door Switch Connections	93
Chapter 10		Environmental Requirements	94
	10.1	Air Quality	94
	10.2	Altitude Operating Range	96
	10.3	Temperature and Humidity	96
Chapter 11		Special Construction Requirements	98
	11.1	Electromagnetic Interference (EMI) Consideration.....	98
	11.2	Radiation Protection Requirements	103
	11.3	Vibration Isolation	106
	11.4	Maximum Gantry Audible Sound Level	107
	11.5	Other Construction Considerations	110
Chapter 12		Communications Requirements	111
	12.1	Network Cable Routing.....	111
	12.2	Broadband Connectivity Information	111

Chapter 1 Safety

1.1 Warning and Safety Messages

Within this publication, paragraph prefixes, such as hazard, caution, danger and warning are used to identify important safety information.

Safety information normally includes:

- Type of potential hazard
- Nature of potential injury
- Causative condition
- How to avoid or correct the causative condition

1.2 Examples of Hazard Statements Used

This manual address four safety classifications, as described below.

 **DANGER**

DANGER IS USED WHEN A HAZARD EXISTS THAT MAY CAUSE SEVERE PERSONAL INJURY OR DEATH IF INSTRUCTIONS ARE IGNORED. THEY INCLUDE FOR EXAMPLE:



- EXCESSIVE VOLTAGE ARINETA - ELECTROCUTION
- CRUSHING POINT - CRUSHING
- RADIATION
- PINCH POINT - SERIOUS INJURY.

 **WARNING**

WARNING IS USED WHEN A HAZARD EXISTS THAT MAY CAUSE SERIOUS PERSONAL INJURY OR DEATH IF INSTRUCTIONS ARE IGNORED. THEY CAN INCLUDE:



- POTENTIAL FOR SHOCK
- EXPOSED WIRES
- ROTATING
- PINCH POINT – INJURY.

 **CAUTION**

Caution is used when a hazard exists that may cause minor injury to oneself or others if instructions are ignored. They include for example:



- Loss of data - loss of critical patient data
- Pinch points - crush or pinch points
- Sharp objects.

Failure to tag and lock out system power may lead to unwanted or unexpected motion.

NOTICE



Notice is used when a hazard is present that may cause property damage, but has absolutely no personal injury risk. They can include:

- Disk drive may crash
- Internal mechanical damage, such as to the X-ray tube
- Coasting the rotor through resonance.

It is important that the reader does not ignore hazard statements in this document.

Chapter 2 Regulatory Information

2.1 Applicable Regulations and Standards

The system is classified as Class II according to FDA's product code classification and Class IIb according to MDR's classification rules . It is rated for continuous operation with intermittent loading, with the maximum permissible ratings. No sterilization is applied. The patient table stretcher and patient support accessories are considered Type B applied parts. The integrated ECG trigger module is considered a Type CF applied part.

This product complies with the requirements of the following regulations and standards:

- Code of Federal Regulations, Title 21, Part 820 — Quality System Regulation
- Code of Federal Regulations, Title 21, Subchapter J — Radiological Health
- Federal U.S. law restricts this device for sale by or on the order of a physician.
- The manufacturer, Arineta Ltd., is ISO 13485 certified.
- The SpotLight system complies with IEC 60601.
- The SpotLight system complies with radiation protection in accordance with IEC 60601-1-3.
- The SpotLight system complies with IEC 60601-2-44, safety of X-ray equipment for computed tomography.
- The SpotLight system complies with IEC 60601-1-2. Detailed information concerning Electromagnetic Compatibility can be found in the Electromagnetic Compatibility chapter of the Technical Reference Manual.
- ROHS Directive 2011/65/EU.
- All portions of the SpotLight system are suitable for use in the patient environment.
- The system should only be used with manufacturer approved equipment.

2.2 Product Description

2.2.1 Intended Use of the System

The SpotLight Computed Tomography X-ray system is intended for head, body, cardiac and vascular X-ray Computed Tomography applications.

2.2.2 Indications for Use of the System

The SpotLight is intended to produce cross-sectional images of the body by computer reconstruction of X-ray transmission projection data taken at different angles. The system has the capability to image whole organs, including the heart, in a single rotation. The system may acquire data using Axial, Cine and Cardiac scan techniques from patients of all ages. These images may be obtained either with or without contrast. This device may include signal analysis and display equipment, patient and equipment supports, components and accessories.

This device may include data and image processing to produce images in a variety of trans-axial and reformatted planes.

The system is indicated for X-ray Computed Tomography imaging of organs that fit in the scan field of view, including cardiac and vascular CT imaging. The device output is useful for diagnosis of disease or abnormality and for planning of therapy procedures.

2.2.3 Contraindications

None known.

2.3 Product Manufacturer

Table 1: SpotLight Product Manufacturer

Model Name	Manufacturer	Distributor
SpotLight/ SpotLight Due	 Arineta Ltd., 15 Halamish St. Caesarea 3088900 Israel Tel: +972 4 6374000 Fax: +972 4 6277006 E-Mail: office@arineta.com	 Distributed by ARINETA Inc.

Chapter 3 Introduction



NOTICE

This document should be reviewed by the Arineta Program Manager of Installation (PMI) for the installation and site service personnel at least six weeks prior to the actual installation.



NOTICE

It is highly recommended that the PMI review the product Installation manual prior to starting an installation, in order to ensure that there are no major changes to the installation process that require additional pre-work.

3.1 Using the Pre-installation Manual

This manual is the official source of prerequisites for installing a SpotLight/SpotLight Duo system. Wherever it is mentioned in the manual, SpotLight system, it refers to all SpotLight family. Topics covered in the manual, include site planning, site preparation and system requirements. This manual is divided into sections to address the requirements of the customer, the system, the environment and on-site construction. It also describes the local and national regulatory requirements, which may be specific to your location.

An Arineta Project Manager of Installation (PMI) is available for specific questions or concerns. The PMI's primary responsibility is to assist the customer with site requirements. This manual is a guide for preparing your SpotLight system. Arineta Architectural Planning must be approved and must completely satisfy all preliminary concepts, site plans and final working drawings. To aid in the process, a checklist is included to stay on track and ensure that all requirements are fulfilled.

Pre-installation includes the procurement and installation of required materials and services necessary for the installation and startup of a CT system.

3.2 Assigning a Site Project Coordinator

It is the customer's (purchaser's) responsibility to assign a site project coordinator.

The site project coordinator is the primary contact and liaison between the construction planners, architects, contractors and any other site administrative personnel for all site-related functions. This individual reports to the purchaser.

The primary responsibility of the site project coordinator, who works closely with Arineta, is to ensure that purchaser upholds all requirements outlined in this manual. To ensure a successful installation, it is recommended that the site project coordinator manage the entire project from pre-installation to final startup, and that he/she be familiar with all phases of pre-installation and installation of similar medical device construction projects. The site project coordinator should read and understand the contents of this manual and be familiar with the installation procedures.

3.3 Site Preparation

The SpotLight System comprises four units for installation:

- The gantry and table are provided in separate packages and are installed as an integrated unit in the shielded scan room.
- The console includes the computer cabinet and accessories that are installed in a control room.
- The PDU may be positioned in the scan room or in a separate utility room, subject to cable length limitations. It is not recommended to position the PDU in the control room.

The units are interconnected by system cables.

In addition, typical installations include a power injector.

The requirements listed in this manual apply to all fixed-site customer installations, including installations within re-locatable buildings. The following requirements represent the **minimum** that a site must meet before beginning **any** new or replacement system installation.

All parties should review these requirements to ensure that the site meets all the following:

- Service requirements
- Regulatory requirements
- Minimum structural, flooring and vibration requirements
- Minimum HVAC requirements
- Minimum electrical requirements
- All network requirements
- All radiation-protection requirements
- All operational clearances
- That all finished doors, floors, windows, ceilings, walls and all plumbing and cabinets are installed

3.4 Customer Responsibility

It is the responsibility of the customer to prepare the site in accordance with all the specifications provided in this manual and be familiar with site-specific drawings and applicable regulations.

Consideration should be given to future expansion during the design phase of the site. It is essential to verify all aspects of the site configuration before construction has begun, as subsequent changes can be costly or impractical.

- **Site Readiness Checklist**

A detailed site-readiness checklist is provided in document PN SRM-16808.

It is the responsibility of the customer to ensure that all requirements of the checklist are fulfilled and that the site conforms to all specifications and requirements detailed in this manual.

- **Planning and Design Work**

The customer will select the location of the site.

All architectural, mechanical and electrical drawings associated with the design and planning of the site are the responsibility of the customer.

Any alterations or modifications to the drawings or to products not specifically included in the sales contract are the customer's responsibility.

The customer shall provide a project coordinator, a clean and safe work environment including proper lighting.

All floors, walls and ceiling should be in a finished state prior to installation, and all site construction renovation completed.

- **Regulatory Compliance**

The customer shall be solely responsible for all regulatory compliance. All work shall comply with national, state and local regulatory and building codes for the location in which the installation occurs. This includes, but is not limited to, permits, inspections, radiation licensing, fire control devices, earthquake regulations, international building codes, service, structural, flooring, vibration, HVAC, electrical, IT network, radiation protection, operational clearance requirements and all applicable codes.

- **Electrical Requirements**

The customer shall be solely responsible for providing all electrical material and service required as outlined and illustrated in this publication. This includes, but is not limited to:

- Installation of all properly sized junction boxes.
- Outlets with covers.
- Line safety switches.
- Fittings installed at the locations specified in the site design.

The customer shall be solely responsible for supplying electrical power of the required voltage, all necessary power supply cables and grounds, all necessary power cables, and grounds to the PDU and an Emergency Off switch in the scan room.



NOTICE

Arineta does not provide or install conduits, junction boxes or ducting illustrated in this publication. Arineta only supplies part of the wires in this publication and customers must supply the rest of wires.

Accessory Installation Accessories ordered for use on the SpotLight system come with their own service manuals and installation instructions provided by the OEM (non-Arineta) supplier. For items not installed by Arineta Service, the customer must ensure that the accessory is installed per OEM specifications. For ceiling, wall or floor-mounted accessories, ensure the item is mounted properly and will not be a hazard to users. Arineta is not responsible for the contents and accuracy of the non-Arineta supplied OEM installation manual.

For items installed by Arineta Service, but for which the pre-installation is under customer responsibility, the customer must ensure that the pre-installation work is performed per OEM specifications. For any ceiling, wall or floor support structure part of the pre-installation requirement, the customer must ensure that those structures have been validated by a mechanical engineer. Arineta is not responsible for the contents and accuracy of the non-Arineta supplied OEM equipment.

3.4.1 Roles and Responsibilities

- **Customer:** Also known as Buyer or Purchaser or End User. This is the entity that has entered into contract with Arineta to buy the product.
- **Arineta Salesperson:** Responsible for completing the customer order process. He/she coordinates the completion of the customer order as required by the customer, for the customer. He/she is responsible for correcting incorrect orders, changing orders, coordinating any replacement of damage in shipment items and resolving missing shipment issues.
- **Arineta Project Manager of Installation (PMI):** Responsibilities include overall project coordination and site planning of Arineta products, as well as managing activities cross-functionally with sales, customer, customer contractors and local field teams in order to ensure that the customer site is designed and prepared to accept and install the product in the facility.
- **Arineta Field Engineer:** Arineta trained and certified field personnel are responsible for the actual assembly, installation, calibration and verification of the proper operation and configuration of the Arineta product. This may include the physical movement of the system and its subcomponents from the point of delivery to the scan suite.
- **Mechanical Installer:** Individuals trained to perform all the tasks to mechanically install the system subcomponents. These individuals may be Arineta personnel or third-party contractors hired by and trained to perform these tasks by Arineta.
- **Zone Broadband Specialist:** Arineta personnel responsible for providing IT expertise and maintaining records of specific network IT connectivity parameters that are required to properly configure the product's connection to the broadband connection provided by the customer.
- **Network IT Personnel:** Dedicated on-site personnel affiliated with or contracted by the customer. They are responsible for providing IT expertise necessary to ensure successful network IT connectivity between the Arineta product and the facility.
- **Qualified Electrician:** Also known as Electrical Contractor. Qualified (certified by a regulatory agency), in-house individual or entity contracted by the customer. Responsible for electrical connections between the customer power source and up to and including the final connection to the Arineta product.
- **Architectural Engineer:** Dedicated on-site personnel affiliated with the customer or contracted by the customer to manage the details of the construction parameters defined by regulatory agencies and as defined by parameters in the *Arineta SpotLight Pre-installation Manual* for the proper installation of the Arineta product.
- **Structural Engineer:** Dedicated on-site personnel affiliated with the customer or contracted by the customer to manage the details of the structural parameters defined by regulatory agencies and as defined by the structural parameters provided in the *Arineta SpotLight Pre-installation Manual* for the proper installation of the Arineta product.
- **HVAC Design Engineer:** Dedicated on-site personnel affiliated with the customer or contracted by the customer to manage the details of the air conditioning and air handling parameters defined by regulatory agencies and as defined by parameters in the *Arineta SpotLight Pre-installation Manual* for the proper installation of the Arineta product.

- **Independent Contractor:** Person or entity who contracts to do work for another person according to his or her own processes and methods. The contractor is not subject to another's control except for what is specified in a mutually binding agreement for a specific job. Such personnel can be contracted by Arineta personnel or by the customer for a unique or special task as part of the Arineta product installation process.
- **Customer-provided Project Coordinator:** A dedicated contact person that works with the Arineta PMI. This individual acts as the single point of contact for the customer. This role is responsible for coordinating with all persons or entities contracted by the customer for the successful installation of an Arineta product.
- **Rigger:** Person, persons or entity hired as an independent contractor to perform a specific task related to the movement of the Arineta product from the point of delivery to the scan suite where it is to be installed.

Chapter 4 System Site Requirements

4.1 System Site Print

A system installation, relocation or move requires a site print. The CT room layout must match the layout detailed on the siteprint.

4.2 Floor Specifications

For information about the weight and floor loading data for the load of the system on the concrete floor directly beneath the table and gantry, see [Floor Loading and Component Weights](#) on page 39. It is very important to check and recognize early in the site planning process that the floor shall maintain the levelness specifications under the much heavier weight of the SpotLight system.

The customer must meet the flooring requirements defined by this pre-installation manual:

- It is recommended to install the SpotLight gantry on a concrete surface. In some sites, it may be necessary to install the gantry on a raised platform.
- The minimum concrete floor thickness beneath the gantry and patient table shall be
- 102.0 mm (4.0 in) (160 mm [6.25 in] for a Seismic site).
- Wood, asphalt and marble floors are prohibited in the foot pad load bearing areas under the gantry and the patient table.
- If the concrete floor has a floor covering installed over it (such as floor tile), the foot pad load bearing areas under the gantry and the patient table shall be cut into the flooring to ensure that the table and gantry rest on a solid surface. (Openings cut during installation.)
- Refer to [Floor Loading and Component Weights](#) on page 39 for the load of the system on the concrete floor directly beneath the table and gantry.
- Arineta floor template (part number SRK-16240) can be used to locate the table and gantry anchor holes, and measure the floor levelness (details are provided in the *Arineta SpotLight Installation Manual*). Contact the Arineta PMI to order the Arineta floor template.
- The floor must have no greater than a 6mm (0.250 in) slope over a 3-meter (9.8 ft) range under the full system load. Levelness is defined as the distance between the highest and lowest points on the floor.
- For older facilities, if the scan room flooring (floor tile, for example) is to be installed or replaced after the gantry and table are installed, the floor should be clean-finished with a dust-free concrete before the system is installed.
- The customer shall be responsible for ensuring that the finished floor material that does not contain hazardous substances, such as lead and asbestos. If these substances are in the flooring material, the Customer shall be responsible for the abatement of this material prior to system installation.

- For new construction, refer to the site print and avoid embedding rebar, electric conduits or any object that may interfere with the installation of the anchors in the concrete directly beneath the table and gantry footprint.
- Shims are not recommended to level the gantry or patient table.

4.3 Related Hospital Equipment Clearances

Check/verify the room layout for the necessary clearances required by any related hospital equipment. Avoid compromising important system features by ensuring that there is ample working space around the patient table for the hospital cart, emergency equipment, personal items and so on.

4.4 Customer Requirements for Site Readiness

- **Site Readiness Completion and Verification**

Installation cannot proceed until all site-readiness requirements have been completed and verified. A site is ready when all renovations/modifications have been completed and the scan suite meets all regulatory, code and system requirements, system delivery needs and all requirements for any options.

- **Contractor's Final Confirmation**

Final confirmation of installation site readiness shall be made by all contractors associated with the project, including the structural engineer/architect, HVAC contractor, electrical contractor, qualified radiological health physicist, cleaning service and so on.

- **Schedule of Site-Ready Visit**

To ensure timely system delivery and installation, the customer shall complete all necessary work listed in this manual and schedule a site-ready PMI visit prior to system delivery.

- **Arineta Site Readiness Checklist**

The customer is responsible for proper site preparation regardless of any Arineta measurements/inspection/assessments. The customer shall fill out and sign the Arineta Site Readiness Checklist, see DOC – SRM-16808.

The PMI works in cooperation with the customer to follow up and ensure that actions in this checklist are complete, and if necessary, aids in the rescheduling of the delivery and installation date.

Chapter 5 Regulatory Requirements

5.1 Building Codes, Regulations and Permits

5.1.1 Building Codes and Regulations

The customer is responsible for ensuring that the scan suite meets all building codes and applicable regulations.

Compliance with the specifications defined in this manual, as well as all federal, state, territory, province, city or local regulations (building codes and so on), are the responsibility of the customer. If a federal, state, territory, province, city or local regulation is in conflict with a specification defined in this manual, the most restrictive of the two specifications applies.

5.1.2 Surface Penetration Permit

Prior to drilling holes in the floor, conduit or any customer surface, a penetration permit for customer approval of the penetrations is required. An Arineta surface penetration permit must be approved by the appropriate facility or building representative. Drilling holes into a concrete floor is an example of surface penetration. The Arineta surface penetration permit can be obtained through Arineta Service Operations.

An Arineta Penetration Permit is not required if the customer has made other arrangements to drill holes, install anchors and provide the necessary mounting hardware as specified in this manual.

5.2 Clearance Regulations

5.2.1 Federal and National Association Regulations

Clearance regulations for all systems installed in the U.S. are determined by various federal agencies and the National Fire Protection Association (NFPA). The regulating publications are: OSHA 29 CFR 1910, NFPA 70E (Standard for Electrical Safety in the Workplace), NFPA 101: (Life Safety Code), NFPA 99: (Standard for Health Care Facilities) and the ADA Amendments Act of 2008 (Americans with Disabilities Act).

**NOTICE**

Code of Federal Regulation (CFR).

Occupational Safety and Health Administration (OSHA)

5.2.2 Federal and Foreign Regulations

All systems installed within the U.S. and its territories must comply with all federal, state and local regulations. Compliance to specifications defined in this manual, as well as all federal, state, territory, province, city or local regulations, is the responsibility of the customer. If a federal, state, territory, province, city or local regulation is in conflict with a specification defined in this manual, the most restrictive of the two specifications applies.

5.3 Codes, Clearances and Service Space Regulation

The diagrams and dimensions used throughout this manual describe the required clearances for proper system operation and servicing only. The customer is responsible for ensuring that all federal, state and local codes and clearances are followed and maintained regarding facility egress and all other related requirements.

Chapter 6 Delivery and Handling

6.1 Project Manager Task List

Table 2: Project Manager Task List

Task	Description
Site Dimensions	The PMI must measure and verify all site dimensions to ensure that the facility can accommodate the delivery of the system (and any related components or equipment), from the delivery drop-off point to the scan suite.
Delivery Type	The PMI must determine the type of delivery: ground level, loading dock or tilt-bed truck.
Delivery Equipment	The PMI must determine if delivery requires special lifting crates or riggers. The PMI must order any additional delivery equipment and all necessary delivery personnel. NOTE: The CT gantry cannot be lifted or transported into the room by any means other than the dolly system. Otherwise, serious damage to the gantry may result.
Identify Delivery Route	The PMI must identify the delivery route, which may include any elevators, doorways and hallways necessary to accommodate the delivery of all system components. NOTE: The customer's structural engineer of record is responsible for ensuring that the floor material and design along the delivery route (loading dock, halls and rooms) meets the forces and weight requirements for the delivery of the individual subsystems to the final installation location within the facility.
Non-Construction-Zone Route to Scan Suite	The PMI must verify an accessible, dust-free, non- construction-zone delivery route to the scan suite.
Packaging Requirements	Project manager orders any construction site packaging requirements prior to shipment. Packaging cannot be modified once the system is shipped.
Floor Protection	The PMI must determine if floor protection is required along the facility delivery route and communicates requirement to delivery company/personnel.

6.2 Minimum Clearance for Doorways and Hallways

Determine room dimensions and verify that doorways adequately accommodate the system. The scan room must have at least one unobstructed clear doorway to move the scanner subsystems in and out of the room. The customer is responsible for removing or protecting any doorway threshold (if one exists) in order to move the scanner subsystems in and out of the room. Identify elevators, doorways and hallways that can accommodate delivery.

Provide floor protection, if needed. Request rigging, if needed.

Table 3: Minimum Doorway Width Requirements

Doorway Clear Opening	Hallway
Minimum Width	
1,024 mm (40.3 in)	2,134 mm (84.0 in)
Minimum Width Needed to Turn Subsystem**	
1,024 mm (40.3 in)	2,134 mm (84.0 in)
1,067 mm (42.0 in)	1,859 mm (73.0 in)
1,346 mm (53.0 in)	1,575 mm (62.0 in)

**Often the table and the gantry must be turned in the hallway to enter the scan room. If there is enough room in the hallway, the minimum doorway width is smaller. If the hallway is smaller in width, the doorway width must increase. This table represents the minimum requirements when combined with average door-width sizes.

Table 4: Minimum Height Requirements

Doorway and path to Room Clear Opening Hallway
1,850.0 mm (73.0 in)

6.3 System Dimensions and Weight

Table 5: System Dimensions and Weight

Gantry	Height mm (in)	Length mm (in)	Width/Depth mm (in)	Weight kg (lb)
Assembled gantry (without covers, including top cover)	1,713.0 (67.45)	1,705.0 (67.13)	663.4 (26.1)	1600 (3,527.5)
Assembled gantry (with covers installed)	1,797.5 (70.7)	1,790.0 (70.5)	943.0 (37.13)	1,644.5 (3625.5)
Assembled gantry (with dollies and without covers attached to gantry)	1,713.0 (67.45)	2,733.0 (107.5)	865.0 (34)	2,086.0 (4,599)
Assembled gantry (with dollies and with covers attached to gantry)	1,797.5 (70.7)	2,733.0 (107.5)	943.0 (37.13)	2,130.5 (4,697)
Patient Table	Height mm (in)	Length mm (in)	Width/Depth mm (in)	Weight kg (lb)
Table (only) *Does not include maximum patient load of 226.8 kg (500 lbs)	Up Position: 830 (32.67) Down Position: 450 (17.71)	1,795.0 (77.6)	564.0 (22.2)	465 (1025)
Console Assembly	Height mm (in)	Length mm (in)	Width/Depth mm (in)	Weight kg (lb)
23-in LCD Monitor	528.0 (20.8)	566.8 (21.9)	227.6 (9.0)	10.8 (23.8)
Scan Control Interface (SCI)	N/A	460.0 (18.1)	270.0 (10.6)	N/A
Keyboard	N/A	460.0 (18.1)	160.0 (6.3)	N/A
Mouse	N/A	70.0 (2.8)	110.0 (4.3)	N/A
Operator Workstation (optional) NOTE: Height can be manually adjusted. Does not include any wall clearance requirements.	N/A	1,520.0 (60.0)	915.0 (36.0)	60.0 (132.2)
Console Cabinet	Height mm (in)	Length mm (in)	Width/Depth mm (in)	Weight kg (lb)
Console Cabinet (with 2 PCs)	707.5 (27.85)	700.0 (27.55)	470.0 (18.5)	43 (95)
Power Distribution Unit (PDU)	Height mm (in)	Length mm (in)	Width/Depth mm (in)	Weight kg (lb)
PDU (only)	825.0 (32.5)	661.0 (26)	730.0 (28.74)	230 (507)

6.4 System Shipping Dimensions and Weight

Table 6: Shipping Dimensions and Weight

Gantry	Height mm (in.)	Length mm (in.)	Width/Depth mm	Weight kg (Lb)
Gantry Transport Crate	2,034 (80)	2,058 (81)	1,158 (46)	1,976 (4,356.4)
Patient Table	Height mm (in)	Length mm (in)	Width/Depth mm (in)	Weight kg (lb)
Patient Table with Transport Wheels NOTE: Table is fully lowered (450.0 mm [17.71 in]) and in home position for shipping *Estimated weight.	908 (36)	2,224 (86)	885 (35)	490 (1,080)
Console Assembly	Height mm (in)	Length mm (in)	Width/Depth mm (in)	Weight kg (lb)
Console Cabinet (with shipping crate)	990 (39)	1,528 (60)	1,128 (44.4)	185 (408)
Power Distribution Unit (PDU)	Height mm (in)	Length mm (in)	Width/Depth mm (in)	Weight kg (lb)
PDU (with shipping crate)	1,127 (48)	844 (33)	834 (33)	250 (551)
Shipping Carts	Height mm (in)	Length mm (in)	Width/Depth mm (in)	Weight kg (lb)
Installation Standard Cables Kit	330 (13)	630 (25)	630 (25)	30 (66)
Installation Long Cables Kits	330 (13)	630 (25)	630 (25)	50 110)

6.5 Delivery Types and System Lifting and Rigging Restrictions

Your PMI determines the most appropriate means of transporting the system to your facility. However, the type of receiving area at the facility where the installation is to occur determines, to a large extent, the method used to transport the system to that facility.

When planning for delivery, facilities fall into two general categories: those with a loading dock and those without a loading dock.

⚠ WARNING



PERSONAL INJURY OR DEATH, EQUIPMENT DAMAGE. TIP HAZARD. GANTRY IS VERY HEAVY AND MAY TIP OVER IF TILTED PAST 10 DEGREES. WHEN TRANSPORTING A SYSTEM TO THE FINAL DESTINATION, DO NOT EXCEED A TILT ANGLE EQUAL TO OR GREATER THAN 10 DEGREES IN EITHER DIRECTION OF AXIS.

- **Loading Dock Deliveries (Preferred Method)**

Facilities with a loading dock in the receiving areas can generally accommodate delivery of the system by semi-tractor trailer. This is the preferred method for system delivery. Dock-to-dock shipment minimizes the possibility of dropping the gantry or damaging other subsystems during the transition from the trailer to the facility. This method also allows for the most efficient packing and unpacking of the system.

- **Ground (Non-Loading-Dock) Deliveries**

Facilities without a loading dock require a lift gate or tilt-bed truck. Such deliveries require unloading the system components from the truck bed to the ground level and then transporting the facility over a smooth surface, such as a concrete sidewalk, driveway or paved area. These paved surfaces must be able to support the weight and width of the subsystems. It may be necessary to protect these surfaces as well.

- **Lift-Gate Truck**

If a truck equipped with a lift gate is used, the delivery truck requires a lift gate rated for at least a 2,722.0 kg (3.0 tons) capacity. When the gantry or table is lowered to ground level, it should be lowered at a steady rate using the slowest speed possible to minimize G-loads when the lift gate reaches the ground. Keep the gantry or table level during movement to avoid flipping. Failure to smoothly transition the table and gantry to ground level may cause serious damage to the table, gantry or their transport dollies.

- **Tilt-Bed Truck Delivery**

Use of a tilt-bed truck is permitted, provided that the tilt does not exceed 10 degrees pitch. If a tilt-bed delivery truck is used, an Arineta representative shall supervise the delivery of the CT scanner to ensure that the system is safely delivered without damage. To avoid damaging the table and gantry, the representative shall direct the driver to attach strapping to the lowest point (not the wheels) of each dolly. When the table or gantry is moved from the back of the delivery truck to ground level, both shall be lowered at the slowest reasonable steady rate until wheel contact is made at ground level. Movement should be temporarily halted when the dolly wheels come in contact with the ground. Further movement should resume, minimizing any G-loads as the final wheels meet ground level. Failure to smoothly transition the table and gantry to ground level may cause serious damage to the table, gantry or their transport dollies.

- Rigging

⚠ WARNING



POSSIBLE SEVERE PERSONAL INJURY OR DEATH.

THE DOLLIES ARE NOT DESIGNED TO BE USED AS AN ATTACHMENT POINT FOR ANY METHOD OF LIFTING THE SUBSYSTEMS. ATTACHING LIFTING STRAPS, CABLES OR MECHANISMS TO THE DOLLY HANDLES OR ANY OTHER PART OF THE DOLLY IS STRICTLY PROHIBITED.

NOTICE



If it is determined that the subsystems must be lifted by crane or other lifting method, the PMI or person responsible for local siting of the system shall NOT proceed with the installation without consulting directly with Arineta Engineering.

Lifting the SpotLight assembly by crane or other lifting methods should always be avoided. All alternate methods of delivery should be evaluated, including the removal of any obstructions, doorways, walls and windows.

Once at the installation site, conveyance of the system into the scan suite may involve special considerations, such as vertical lifting or transportation through stairwells, which involves additional planning by the PMI.

If lifting is still required:

- The PMI must ensure that the rigging/moving company is an Arineta Approved /Qualified Contractor.
- The entire gantry assembly and both gantry transport side dollies must be placed on the lifting platform. Use the same platform as that used for the shipping box.



NOTICE

If the platform has limited space, the gantry transport side dollies may be removed during the lift operation. Once the lift operation is completed, the gantry transport side dollies must be installed back on the gantry assembly.

- The platform must be designed such that no lifting straps or cables come in contact with any part of the gantry or table subsystems or its side dollies.
- The lifting platform must be able to lift the entire load. No part of the subsystem can bear any load during the lift.



NOTICE

If delivery requires vertical or horizontal lifting, the PMI must add the necessary identifier to the order.

Both vertical and horizontal lifting requires professional riggers. The PMI should always notify CT engineering before attempting either lifting procedures and should ensure that the order includes the necessary lifting fixtures, as both vertical and horizontal fixtures must appear on the order for them to ship with the system:

- If the delivery requires horizontal lifting, the PMI adds the corresponding identifier to the order. The dollies for horizontal lifting with lifting instructions for riggers are delivered separately and must be attached to gantry after opening the box.
- If the delivery requires vertical lifting, the PMI adds the appropriate vertical identifier accessories to the order **OPT-20956** (eye bolts).

Illustration 1: Vertical Lifting Accessories – Eye-Bolt Lifting Hooks- OPT-20956



NOTICE

The eye-bolt lifting hooks are not part of the shipping system. A special order must be added for the vertical lifting hooks-**OPT-20956**.

Illustration 2: Vertical Eye-Bolt Lifting Hooks Attached to the Gantry

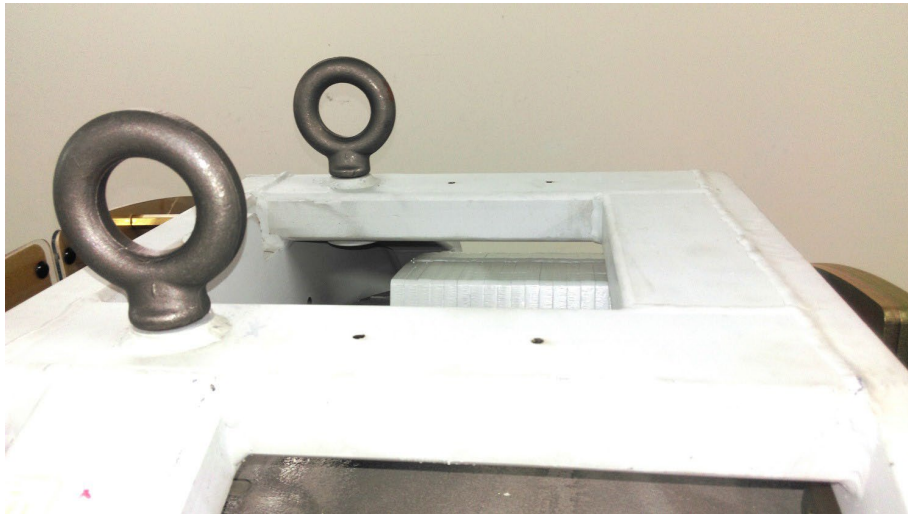

NOTICE

The vertical eye-bolts lifting hooks should be attached to the system without the system shipping box and without covers (front, rear, top and side covers).

Contact Installation Support Services to remove the system covers before attaching the eye-bolt lifting hooks.

Illustration 3: Vertical Lifting with Crane with Eye Bolts



6.6 Shipping and Receiving

6.6.1 Handling Restrictions

- **Shock Restrictions:** The system cannot tolerate shock or vibration. System components cannot be tipped, dropped or hoisted. The PMI must communicate these restrictions to everyone involved with handling the system components.
- **Rolling on Surfaces:** System components must be rolled across smooth surfaces (sidewalks, parking lots, tile flooring and so on) only. If a smooth surface is not available (for example, a sidewalk or driveway has cracks or uneven joints, or a tiled floor has deep or rough joint lines), then floor protection must be used to move the system across the uneven surface.
- **Shipping Crate/Packaging Integrity:** Do not damage or puncture the shipping crate or packaging.

Floor Protection

To protect the floor during delivery, floor protection must be used along the entire delivery path and throughout the scan suite, where necessary.

- **Door Threshold Not Allowed**

The customer is responsible for removing any doorway threshold (if one exists), in order to move the scanner subsystems in and out of the room.

- **Floor Load Along Delivery Route**

The customer's structural engineer of record is responsible for making sure that the floor material and design along the delivery route (loading dock, halls and rooms) meets the forces and weight requirements for the delivery of the individual subsystems to the final installation location within the facility.

6.6.2 Dollies, Installation and Shipping Carts

The gantry dollies are shipped in a separate cart from the system packaging.

The square footage required for the installation and shipping carts storage can be calculated based on the dimensions in Table 6 on [page 30](#).

After using the dollies to lift and install the gantry in the hospital room, the dollies must be returned to the local Arineta office or warehouse.

Instructions for how to install the dollies are available in the *Arineta SpotLight Installation Manual* and the *Arineta SpotLight Service Manual*.



NOTICE

The dollies sides are not identical. Each dolly has a different part number. Make sure that you order and receive two dollies, which can be assembled for the SpotLight system.

Illustration 4: Gantry with Shipping Dollies



6.6.3 Delivery Temperature and Humidity Tolerance

When transporting the system, excluding any scanner LCD display monitors, water-filled calibration/IQ phantoms and covers, the temperature must remain within the range of -40 to +70°C (-40 to +158°F), inclusive.

When transporting the system, excluding water-filled calibration/IQ phantoms, all packing material must remain intact and the relative humidity must remain within the range of 5% to 95%, inclusive.



NOTICE

See the table below for the shipping temperature and humidity ranges of excluded items.

Table 7: Shipping Temperature and Humidity Ranges for Excluded Items

Item	Temperature	Humidity
LCD Monitors	-20 to +60°C (-4 to +140°F)	5% to 95%
Water-filled Calibration/IQ Phantoms	+5 to +70°C (+41 to +158°F)	5% to 95%

After delivery to the scan suite and before unpacking any system components, allow 12 hours for the equipment to adjust to room temperature to avoid condensation or rapid temperature change. This 12-hour warm-up period is not required if the shipping environment meets the same temperature and humidity requirements as the scan room and the system components are already at steady room temperature.

6.6.4 Unpacking the System

Do not remove any protective wrapper or packaging from any system component until all construction is complete and all construction dust is removed from the installation site.

Do not remove the console cabinet from the shipping box until after the unit has been delivered to the scan suite location.

6.6.5 Storage Requirements



NOTICE

Failure to adhere to storage requirements can result in equipment damage.

6.6.6 Short-Term Storage (Less Than Six Months)

If storing a system prior to installation, the system must be stored in its original packaging in a temperature- and humidity-controlled environment protected from water and dust. It is recommended that storage of the system not exceed six months. If storage will exceed six months, contact your PMI for long-term storage procedures.

Table 8: Humidity and Ambient Temperatures for Storage

Ambient temperature must be maintained within a range of:	+4 to +35°C (+40 to +95°F)
Maximum rate of change in the temperature must not exceed:	3°C per hour (+5.4°F)
Relative humidity (non-condensing) must be maintained within a range of:	20 to 60% RH
Maximum rate of change in the relative humidity must not exceed:	5% RH per hour
* Storage for longer than six months is prohibited.	



NOTICE

Storage between delivery stages qualifies as short-term storage. Van storage must meet the same specifications as those listed above.

6.6.7 Construction-Site Storage

When storing the SpotLight system at a construction site, do not damage or puncture the shipping crates. Keep the units intact. Do not remove packaging until all construction is completed at the site and all dust created by the construction is removed:

- Maintain a storage temperature within the range of 10–32°C (50–90°F).
- Maintain a relative humidity (non-condensing) between 20–70%.

6.6.8 Extreme Temperature Delivery

Avoid extreme temperature during system transportation and delivery. Extreme temperatures consist of temperatures below -18°C (0°F), or above 49°C (120°F), without humidity control.

When transporting the SpotLight system, prevent any exposure of the system to temperatures or humidity out of the following specifications:

- Temperature: -20° to +60°C (-4° to +140°F)
- Humidity: 5% to 95%

NOTICE



Component freezing and possible damage occurs when exposing the packed SpotLight system to temperatures below -18°C (0°F) for a period longer than two (2) days. Allow a minimum of 12 hours for the packed CT system to adjust to ambient room temperature prior to opening the packaging.

Failure to adhere to extreme temperature requirements during delivery and storage can result in equipment damage.

Chapter 7 Equipment Requirements

7.1 Floor Loading and Component Weights

The customer’s contractor and structural engineer should use the information in the table below to help determine if the floor structure in the scan suite possesses sufficient strength to support the weight of the system

Table 9: Component Weight and Floor Loading Data

System Component	Net Weight	Maximum Uplift Load N (Lbf)	Maximum Compressive Floor Pressure per Pad MPa (psi)	Number of Foot Pads
Gantry with covers	1645 kg (3627 lb)	NA	1.27 (184)	4 (63.5 mm (2.5 in) in diameter)
System Component	Net Weight	Maximum Uplift Load N (Lbf)	N/A	Number of Foot Pads
Table with 226.8 kg (500 lb) patient	692 kg (1525 lb)	1000 (225)	1.1 (160)	5 (63.5 mm (2.5 in) in diameter)
<p>NOTES:</p> <ol style="list-style-type: none"> Maximum uplift load values were determined with the table fully extended for the worst-case condition. Exact floor locations of the table and gantry footpads are documented in the site print provided to the customer. Values in Table 2 do not include safety factors. Refer to Anchor Safety Factors on page 49 for a discussion on safety factors. The patient table values are based on 1 x patient load plus 1 x empty 				

Illustration 5: Gantry Flooring Loading on Predefined Position

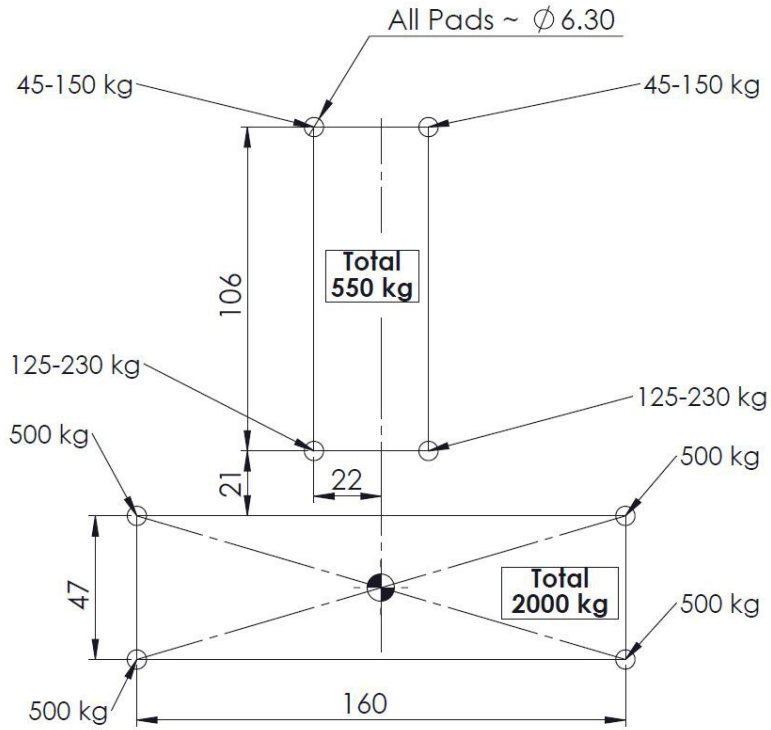
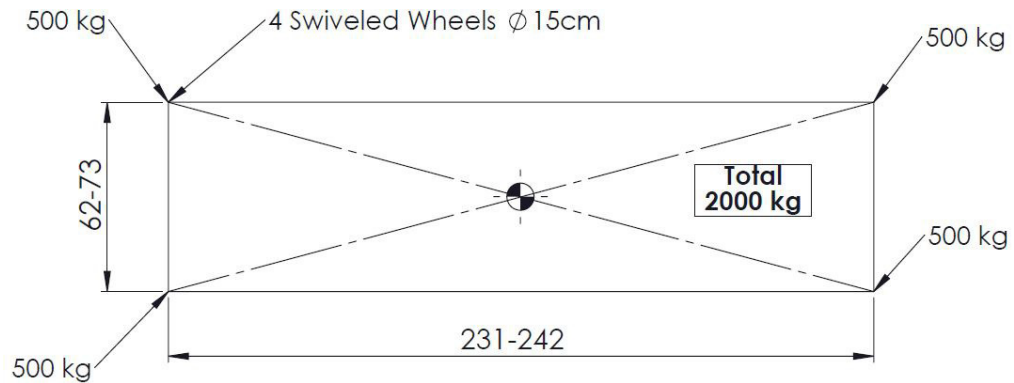

Illustration 6: Gantry Flooring Loading During Transposition with Dollies



NOTICE

All dimensions are in centimeters (cm).

7.2 System Component Dimensions Diagram

Illustration 7: System Dimensions – 1

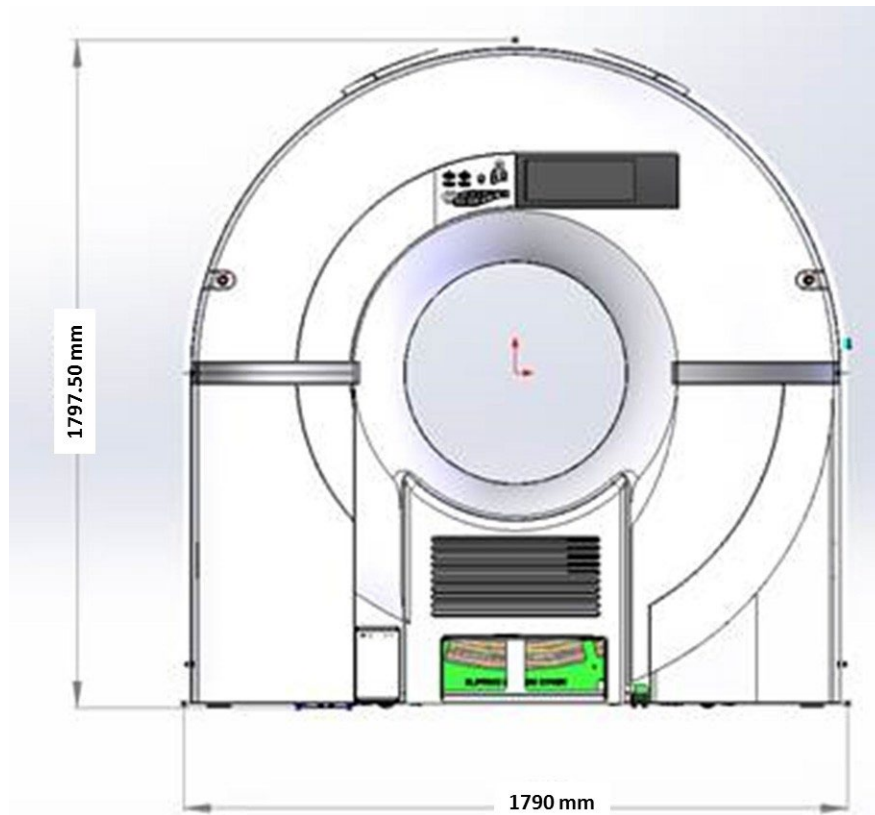
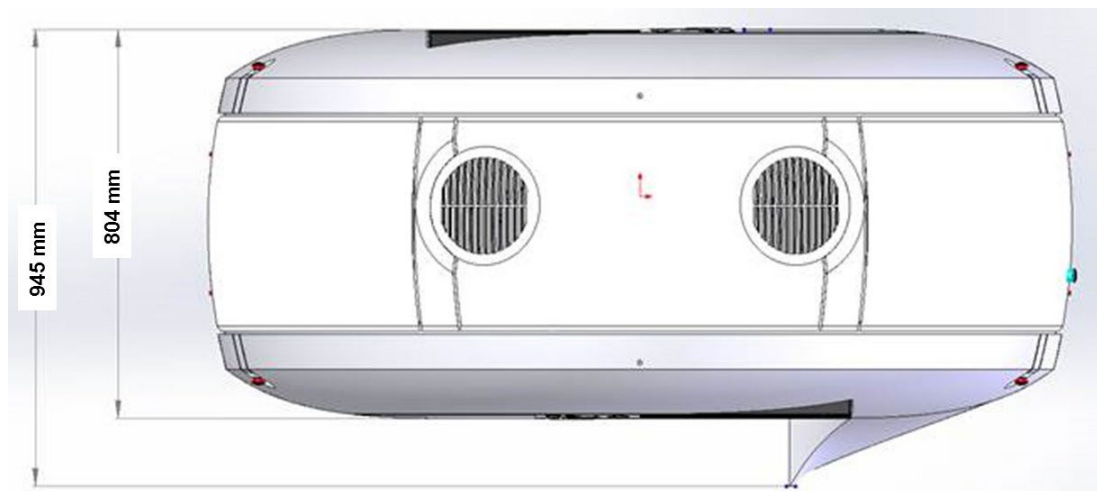

Illustration 8: System Dimensions – 2



Air Flow: Exhaust air is pushed through the top cover vents.

Illustration 9: Air Flow

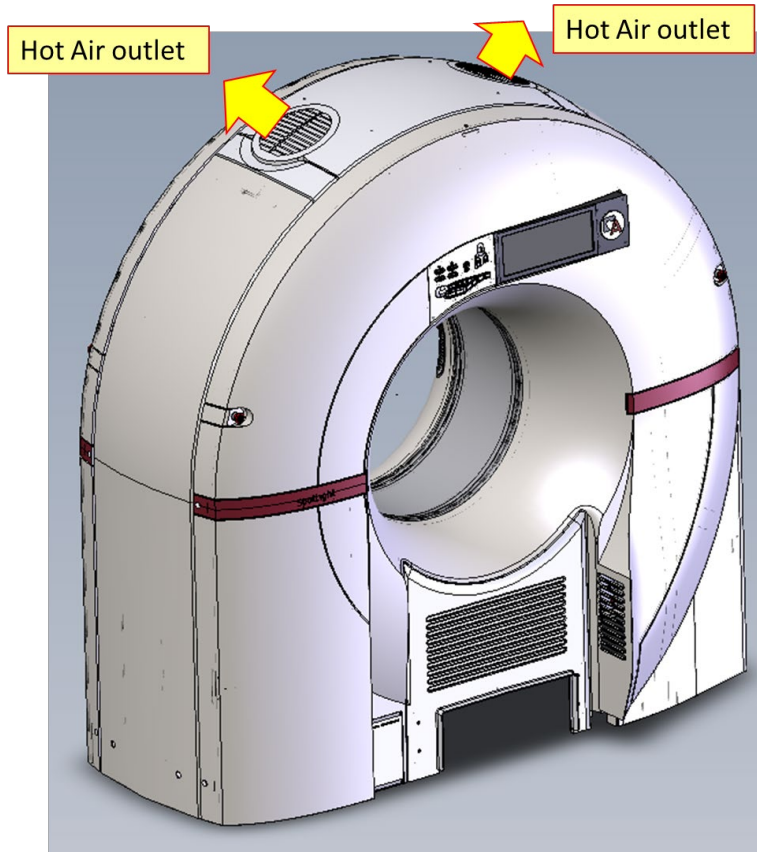

Illustration 10: Table and Gantry (Top View Dimensions)

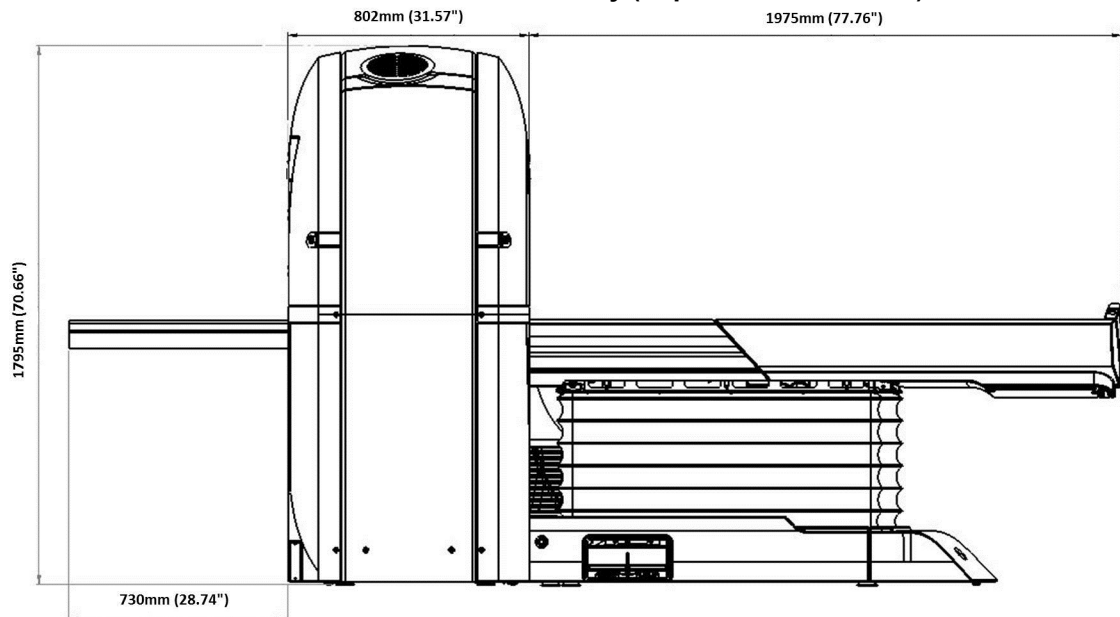

Illustration 11: Table (Side View Dimensions)

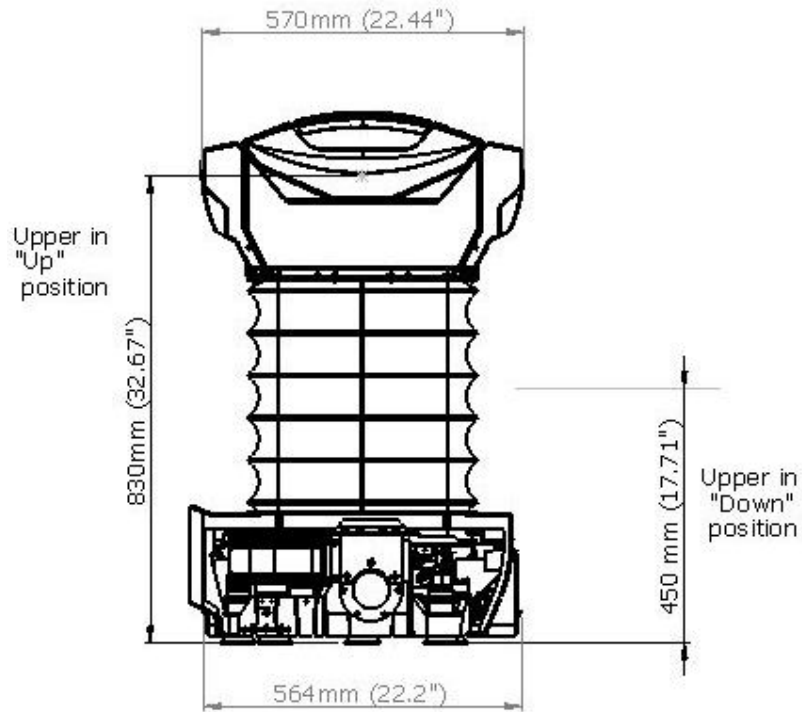
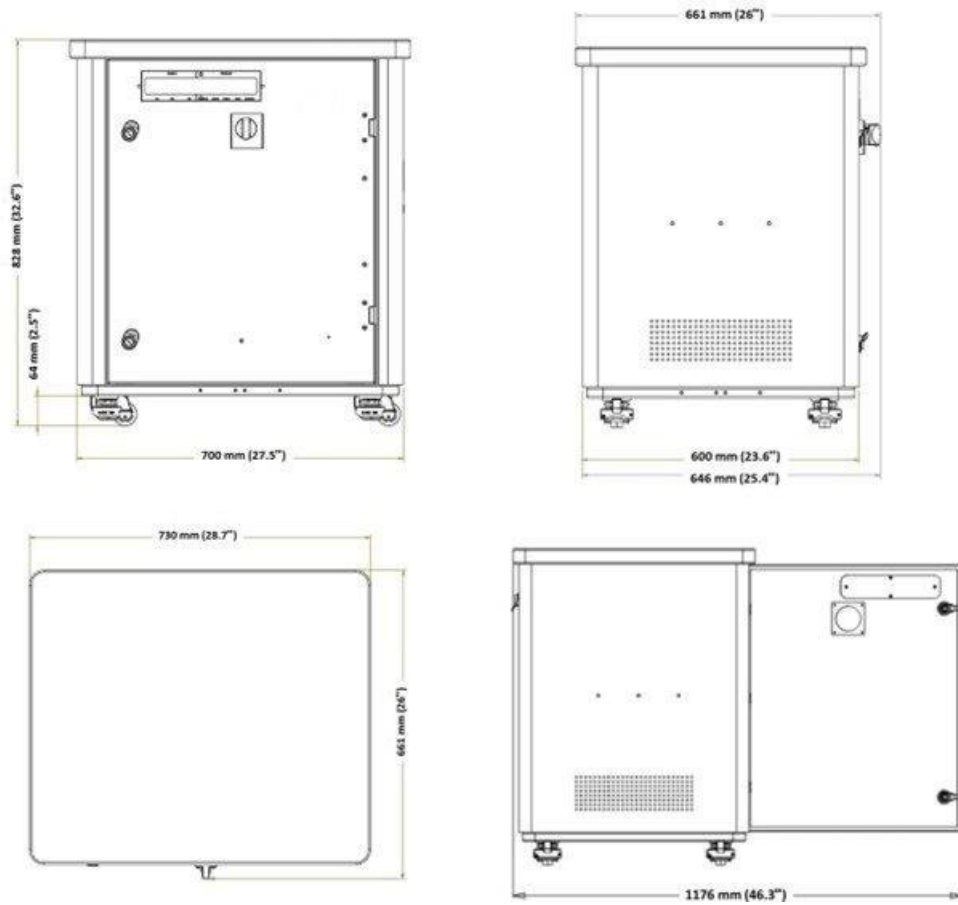

Illustration 12: Power Distribution Unit Dimensions



Air Flow: Intake air is pulled through the chimney cover at the side of the PDU. Exhaust air is pushed through the side covers located at the bottom of the PDU.

Illustration 13: PDU Air Intake and Service Areas

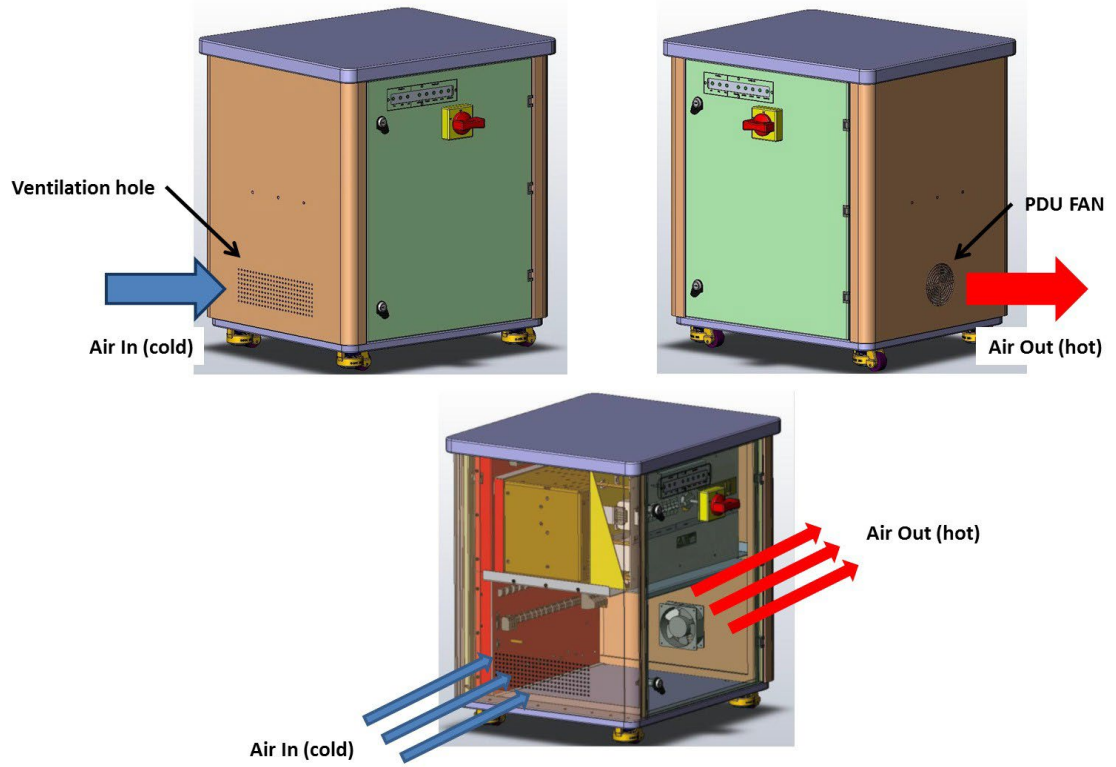
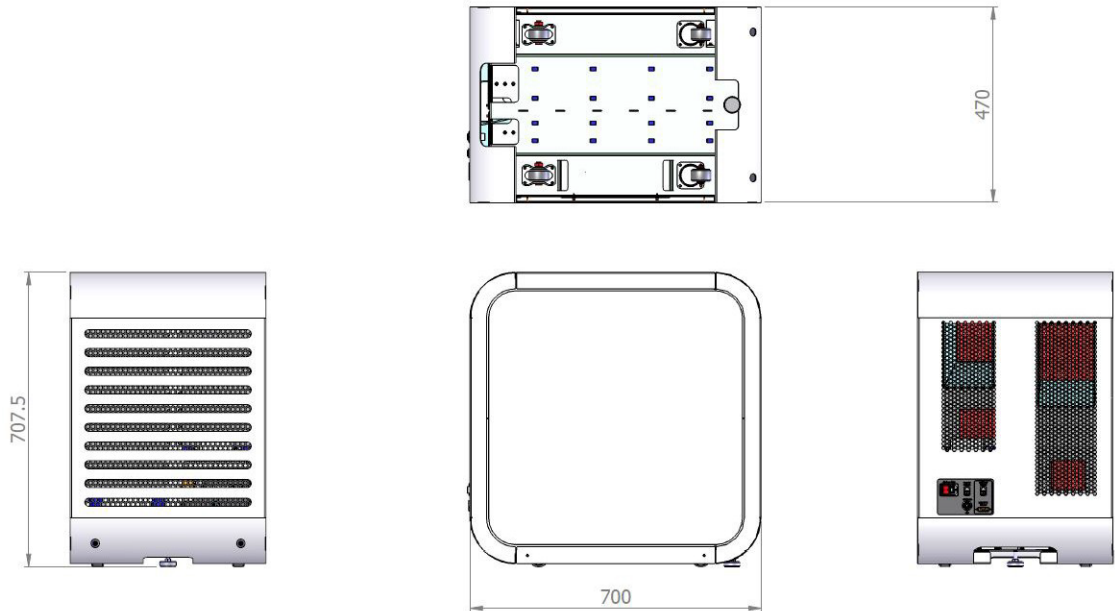

Illustration 14: Operator Console Cabinet



7.3 System Component Center-of-Gravity Diagrams

The information in the following figures provide the customer's contractor and/or structural engineer with center-of-gravity information to assist in seismic calculations for the system.

Illustration 15: Gantry Center-of-Gravity

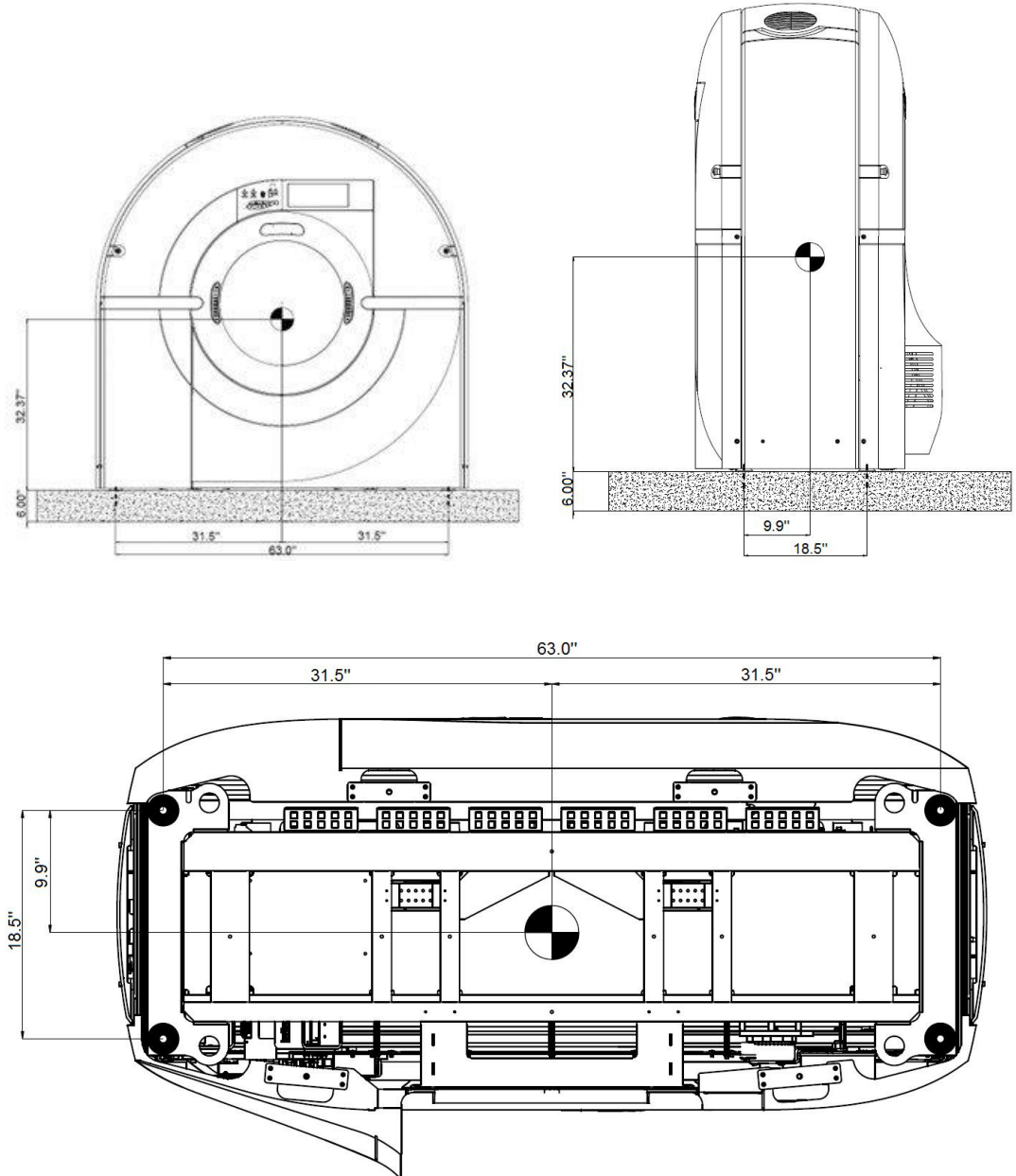
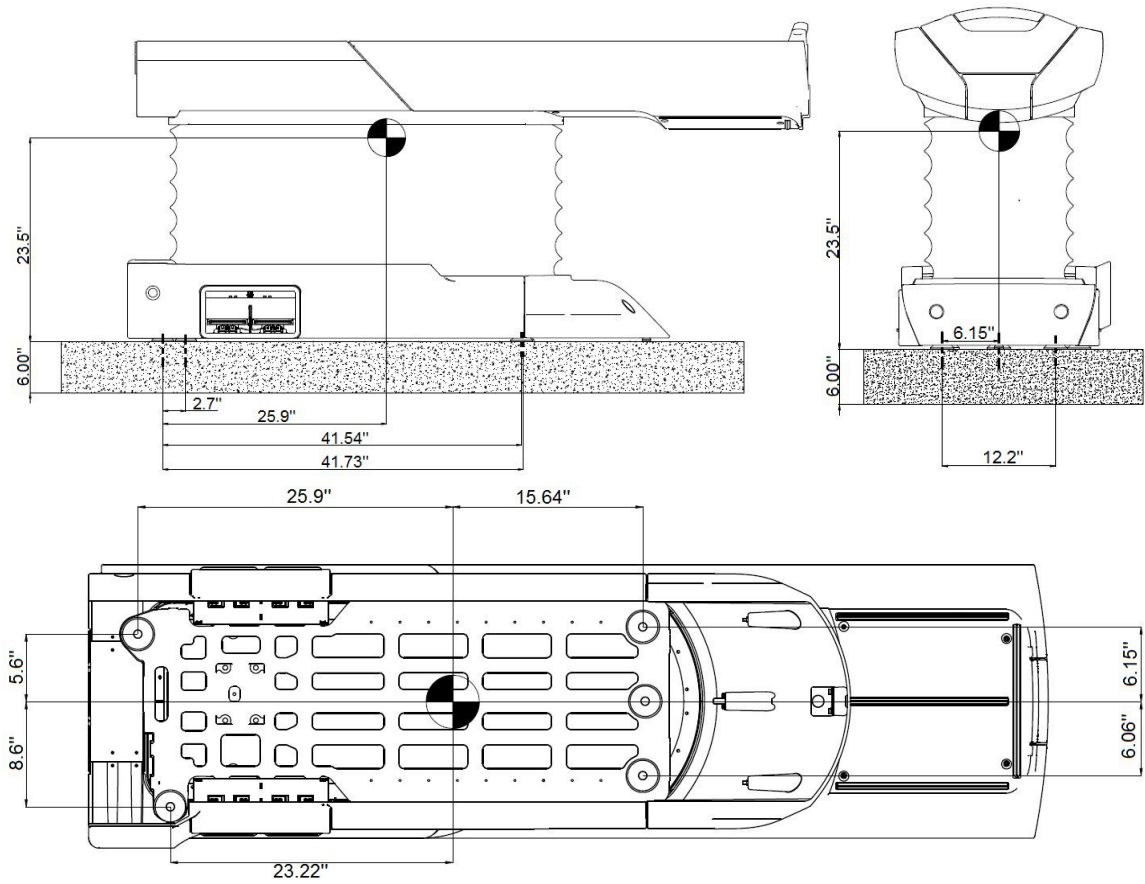

Illustration 16: Table Center-of-Gravity



NOTICE

The Center-of-Gravity location marked above includes the mass of a maximum-weight patient on the table with a fully extended table.

Illustration 17: PDU Center-of-Gravity

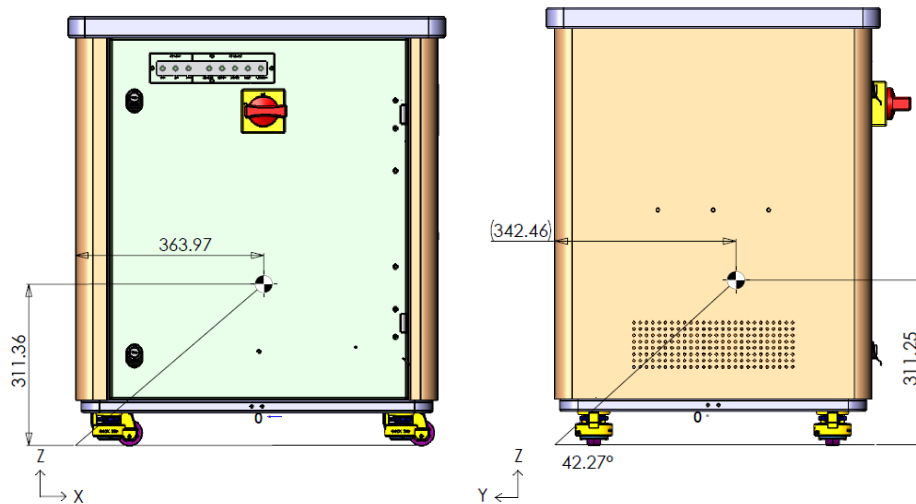
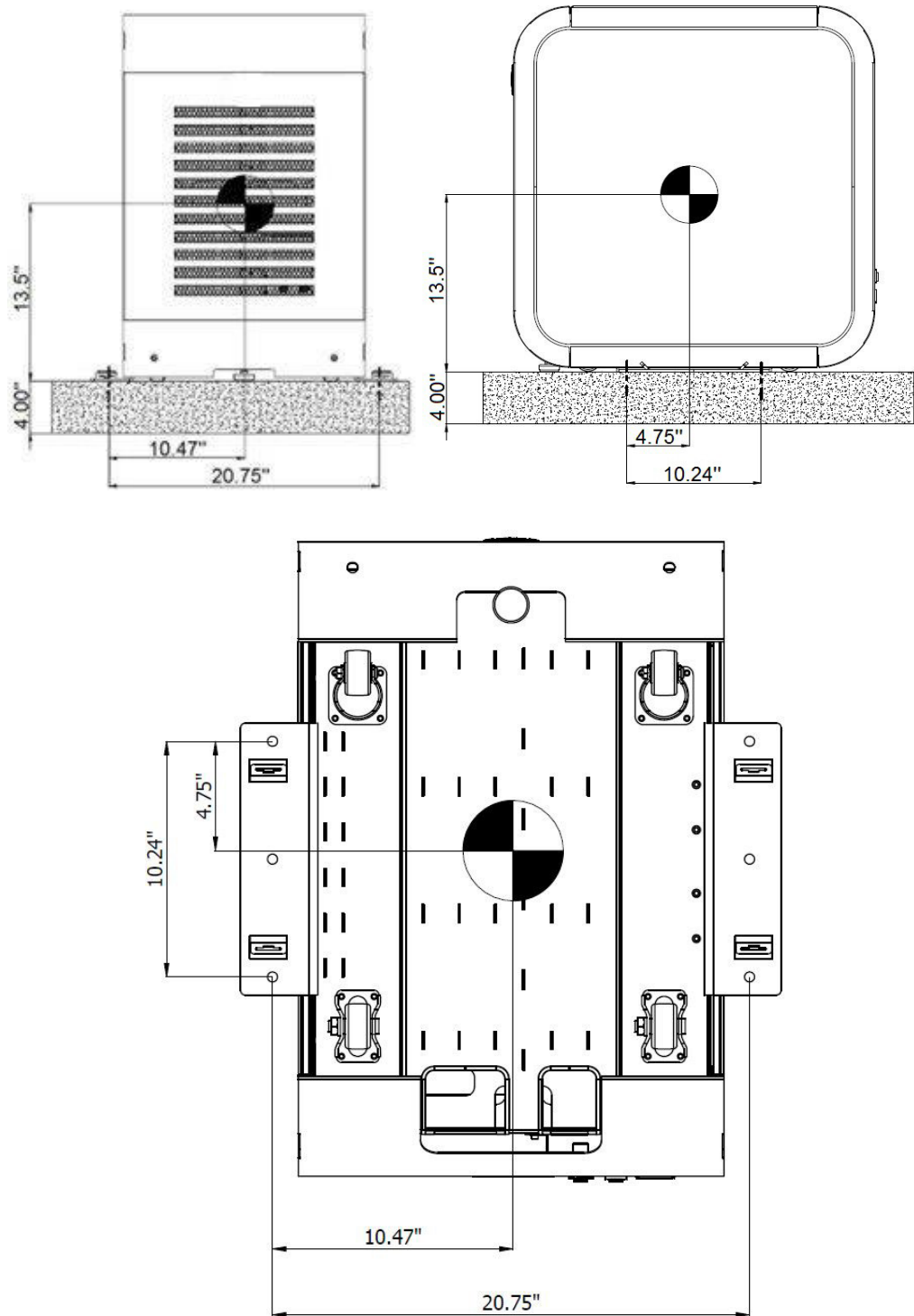

Illustration 18: Console Center-of-Gravity



7.4 Anchoring

⚠ DANGER



AN IMPROPERLY SECURED SYSTEM MAY RESULT IN DEATH OR SERIOUS INJURY. THE SYSTEM CAN MOVE OR TIP DURING OPERATION IF NOT PROPERLY SECURED. PATIENT SAFETY DURING SYSTEM OPERATION REQUIRES PROPER ANCHORING OF THE SYSTEM.

⚠ WARNING



FAILURE TO ASSEMBLE CORRECTLY OR APPLY PROPER TORQUE MAY RESULT IN DEATH OR SERIOUS INJURY. THE SYSTEM CAN MOVE, TIP OVER AND FALL ON OTHER COMPONENTS. FOLLOWING THE ANCHOR METHOD SATISFIES THE SAFETY FACTOR OF FOUR AGAINST THE LOADING CONDITION.

⚠ CAUTION



Alternate system anchoring is not recommended. Any alternate System anchoring must meet the minimum requirements defined for the anchors supplied by Arineta. The customer is responsible for meeting all code requirements specific to the site and for this product when using alternate system anchoring.

7.4.1 Anchor Safety Factors

Arineta provides an anchoring method, which is designed to a safety factor of 4 against the loading conditions described in Table 9 on page 39. The safety factor of 4 was chosen to ensure that the patient table does not tip over, which could result in death or serious injury. The choice of a safety factor of 4 is also based on medical device safety standards.

For example, for a 500lb table, 4 times of the maximum uplift is $4 \times 500 = 2,000$ Lbf

NOTICE



If rebar is hit when drilling a hole, immediately stop drilling and use the alternative anchor point for that anchor. If rebar or something is hit in the alternate anchor point, escalate the issue. The local inspector must be contacted before drilling through rebar in the floor.

It is the customer's responsibility to have a licensed structural engineer work in conjunction with a qualified contractor to mount the gantry and patient table to the floor. The customer must consult a licensed architect, licensed structural engineer, qualified contractor or the PMI to resolve all anchoring issues. The customer or customer's structural engineer is responsible for making sure that the floor material and design comply with the forces and weight requirements for the installation and anchoring of the subsystems to the floor.

Arineta supplies anchors for mounting the table and the gantry. The console and PDU do not require anchoring to the floor:

- The gantry and table require secure anchoring to the scan room floor. The PDU and the console cabinet lie on the floor with extractable legs.
- Anchors mount through the gantry and table supports. Use the floor template or its dimensions to locate the table and gantry support positions within the scan room, making sure that any anchors that pass through the supports clear all structural beams and interferences in the floor.

- If a loading analysis determines that the gantry and table position should change relative to their position on the site print, be sure to consider the clearance requirements when determining a new appropriate location for the scanner.
- Hospitals and scanning facilities throughout the world may utilize a variety of floor types, and the disposition of different floor types may necessitate additional planning to adequately accommodate the scanner.

Arineta strongly recommends using a solid concrete base underneath the gantry and the table with a minimum thickness of 102 mm (4.0 in) (in a Seismic site, the minimum floor thickness of 160 mm [6.25 in]) using Arineta-supplied anchoring gear. For the recommended concrete base dimensions and anchor positions, see System Component Center-of-Gravity Diagrams [on page 46](#).

Wood floors often require substantial reinforcement. Arineta does not recommend using wood floors.

Temperature variation in blacktop or marble floors may allow anchor movement and pullout. Arineta does not recommend using blacktop or marble floors.

NOTICE



Responsibility for providing an approved support structure and mounting method for all floor types other than the company-recommended floor rests with the purchaser.

The company accepts no responsibility for any failure of the support structure or anchoring method, including those used for seismic mounting. The company accepts no responsibility for methods other than those listed. See Supplied Anchoring [on page 53](#) for more details.

7.4.2 Surface Preparation and Requirements

Prior to Arineta personnel drilling holes in the floor, conduit or any customer surface, a penetration permit for customer approval of the penetrations is required. See Building Codes, Regulations and Permits [on page 25](#) for more details.

Each floor anchor must be installed to clear any structural object hidden or buried in the floor. Hidden objects could be floor beams, rebar and concrete wire mesh.

Anchors must be installed no less than 100.0 mm (3.9 in) from the edge of the concrete slab or from any expansion joint. The anchor supplied by Arineta for non-seismic anchoring purposes is: HILTI expansion anchor HST3-H M12 x 145mm.

The minimum concrete floor thickness beneath the gantry and patient table must be 102 mm (4.0 in).

7.4.3 Anchor Hammer Drill Bit

The anchor provided requires a 1/2in masonry drill bit to drill a minimum of nine holes in the concrete floor. This drill bit is not provided and should be acquired prior to the first day of installation.

The recommended drill bit for SDS and SDS Plus-type hammer drill chucks is Bosch mfg.

#HCFC2084, Grainger part number 36H612 or equivalent. This specific drill bit has a full cutter head and is designed to drill through rebar. The overall length of the drill, including the shank, is 12 inches. The shank size is 25/64. The use of drill bits with less than a full cutter head may result in incorrect hole size. It may also cause a delay in the installation due to excessive drill tip wear if rebar is hit during the drilling process.

7.4.4 Anchor Points

Only the gantry and patient table are required to be securely anchored to the floor in a non-seismic environment. Gantry installations must use a minimum of four (4) floor anchors — one at each corner of the gantry. The patient table uses a minimum of five (5) anchors.

An Arineta floor template (part number SRK-16240) can be used to locate the table and gantry anchor holes. Contact your Arineta PMI to order the Arineta floor template.

The PDU and system cabinet do not require anchoring to the floor in a non-seismic installation. See [Seismic Anchoring Methods on page 55](#) for more details.

Illustration 19: Anchoring Point Location – Gantry and Table

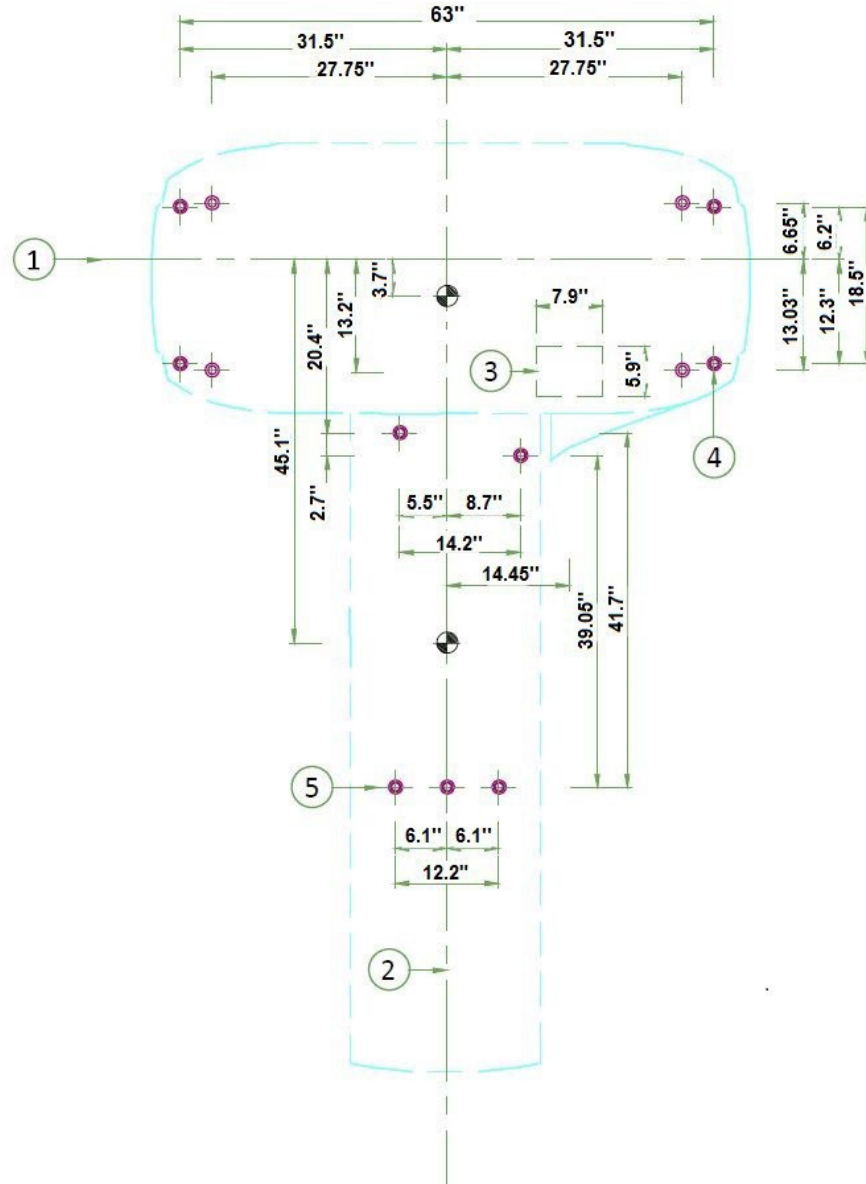





Table 10: Anchoring Location Information

#	Description	#	Description
1	Tilting axis	5	Five table anchoring points
2	Longitudinal axis		Center of gravity
3	Cable inlet area (200 x 150 mm)		Main anchoring points
4	Eight gantry anchoring points		Alternate anchoring points

7.4.5 Supplied Anchoring

Table 11: Arineta-supplied Anchors

Hilti Part Number	387528
Description	Expansion anchor HST3-H M12 x 145 mm
Diameter	12 mm
Length	5-1/2"

Illustration 20: Gantry and Table Anchoring Diagram

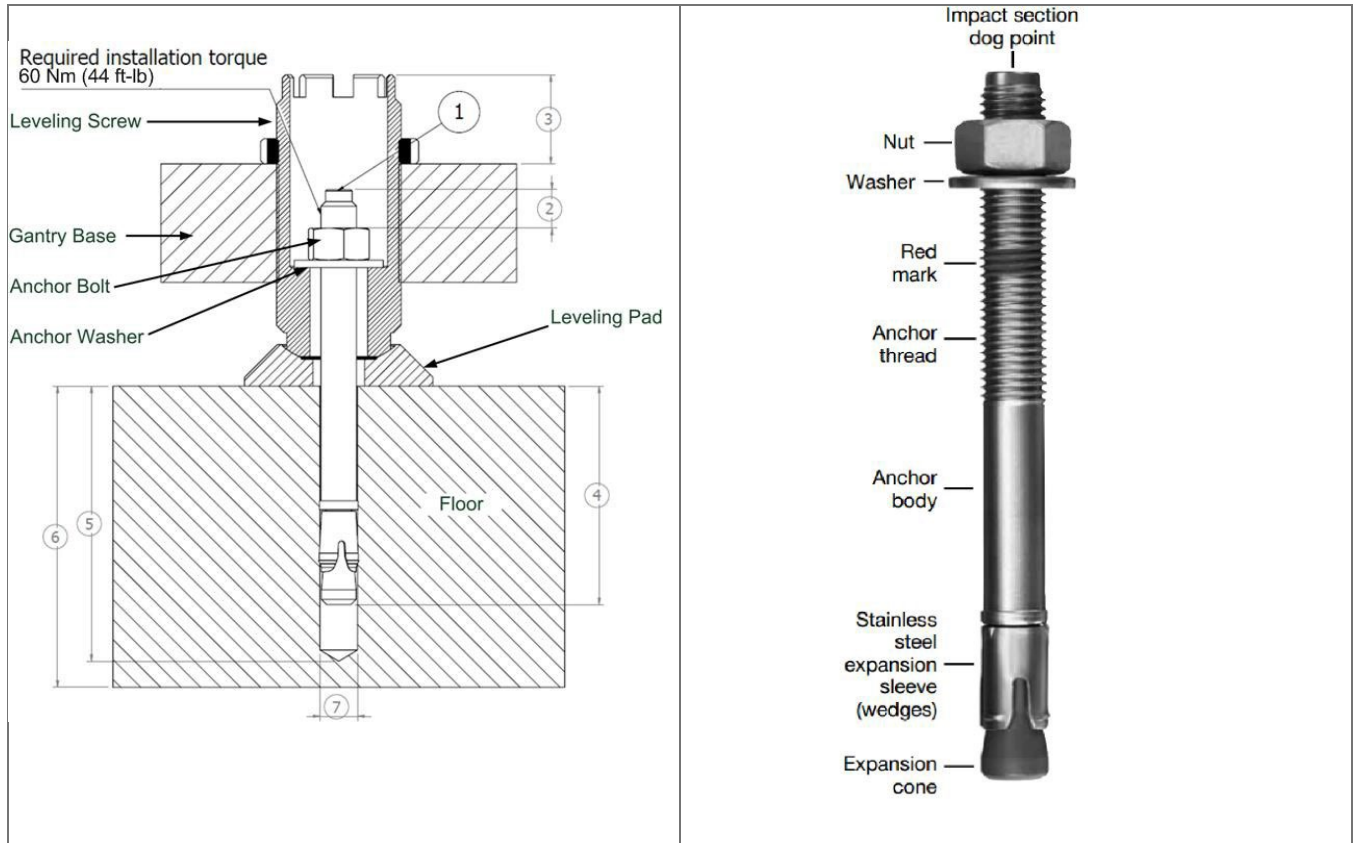

NOTICE

The gantry and the table have the same anchor type.

Table 12: Table and Gantry Anchoring Requirements

#	Mounting Requirements	Table	Gantry
1	Anchor Type - provided by Arineta	HST3-H M12 x 145 mm	HST3-H M12 x 145 mm
2	Maximum Distance after Proper Torque (a)	30.0 mm (1.18 in)	30.0 mm (1.18 in)
3	Initial Height from the Floor	25.0 mm (0.98 in) +/- 5.0 mm (0.197 in)	55.0 mm (2.91 in) +/- 5.0 mm (0.197 in)
4	Nominal Embedment Before Anchor is Torqued	75.0 mm (2.95 in) minimum	75.0 mm (2.95 in) minimum 63.0 mm (2.5 in)

		63.0 mm (2.5 in)	
5	Recommended Drilling Depth	95 mm (3-3/4 in)	95 mm (3-3/4 in)
6	Minimum Floor Thickness	102 mm (4.0 in)	102 mm (4.0 in)
7	Drill Bit	12 mm	12 mm
(a) The starting insertion depth is 13.0 mm (0.51 in), which is the set amount of threads exposed when the anchor is installed in the hole. The anchor is hammered into the hole with the nut and washer installed until the washer bottoms out on the anchor washer (item #5 above).			

7.4.6 Alternative Anchoring Methods

- If an alternate method of anchoring is utilized, the customer is responsible for confirming that the anchors can meet the loading described in Weight and Floor Loading Data. Arineta requires designing this alternate anchoring solution to at least a safety factor of 4. Check local governing building codes to see if an additional safety factor is required. The customer shall confirm the load capability of the anchoring solution after installation to the loading provided in Weight and Floor Loading Data. Examples of confirmation methods are a pull-up test (with load transducer) or torque test.
- If a customer does not use the anchor method defined in the installation manual, the customer is responsible for having an *Alternative Anchoring Plan* developed by a Structural Engineering firm at the cost of the customer. The Alternative Anchoring Plan should be then executed at time of installation in place of the existing anchoring method defined in the product installation manual. This plan must be retained by the customer, since it must be reviewed by service personnel at the time of de-installation.
- The anchoring method defined in this manual applies only on the gantry. Modification of this anchoring method or improvising within the procedure defined in this manual is not allowed.
- Arineta and workers contracted by Arineta are not responsible for any failure of an anchoring system not authorized by Arineta.
- This procedure at times requires a minimum of two people. Only trained personnel should install this product.
- Floor protection must be used, as necessary, when positioning all subsystems.
- If there is not enough room to assemble the gantry in the scan room, the gantry can be assembled in another location and then transported to the scan room as an assembled unit, providing that the delivery route and doorway openings can accommodate the assembled gantry with its two gantry side dollies attached.

7.4.7 Seismic Anchoring Methods

For a seismic installation, the customer must refer to all applicable state/local laws and building codes. The customer must consult with the structural engineer, site contractor or architect for seismic installation requirements pertaining to all scanner components/subsystems.

Seismic anchoring is considered to be an alternate anchoring method. An alternative installation plan that meets all required seismic codes for the region the product is located in should be developed for sites requiring seismic installations. Development of this plan is the responsibility of the customer. Generally, this requires the customer to contract the services of a structural engineering firm to develop the seismic anchoring plan prior to installation. The alternative seismic installation plan should be executed at the time of installation in place of the existing anchoring method defined in the product installation manual. This plan must be retained by the customer, since it must be reviewed by service personnel at the time of de-installation.

Use the seismic anchoring kit (KIT-15940). The kit provided by Arineta is designed for anchors that are 5/8 in (15.9 mm) in diameter. Anchors of this size are not provided by Arineta. The type and length of the anchor must be defined in the alternative seismic anchoring plan and purchased separately by the customer.

The existing 12mm anchors provided by Arineta should be discarded and not used for seismic installations.

7.4.7.1 Gantry and Table – Seismic Methods

Arineta supplies a seismic kit for gantry, table and PDU installation as a purchased option (KIT-15940). The Arineta seismic kit is designed for use with 5/8 in (15.9 mm) anchors (eight for the gantry and five for the table).

However, Arineta does not supply anchors with the seismic kit. It is the responsibility of the customer to have qualified structural engineers to determine and supply the correct seismic anchors.

The customer's contractor will often supply the installation instructions for a seismic region in a certified print or equivalent.

The Arineta floor template (part number SRK-16240) contains the details of both gantry and table anchor locations. Primary and alternate anchors for the gantry and table, as shown in [Illustration 21](#) and [Illustration 22](#), respectively, must be used for seismic installation.

Illustration 21: Gantry Anchor Location

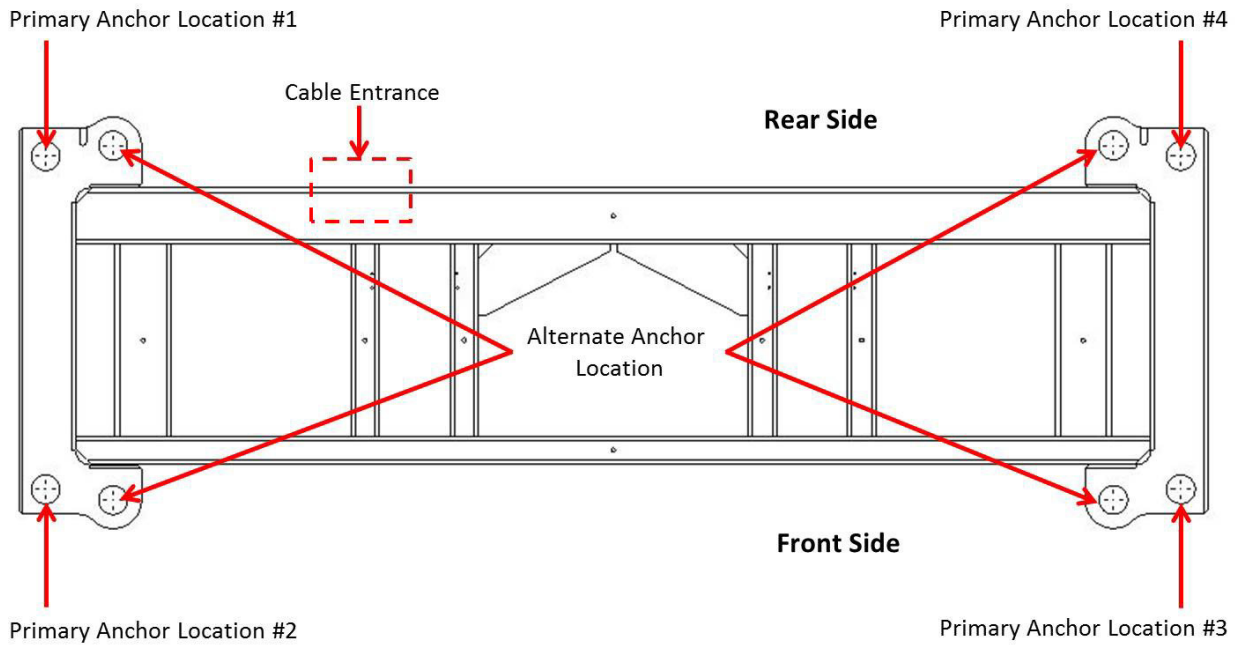

Illustration 22: Table Anchor Location

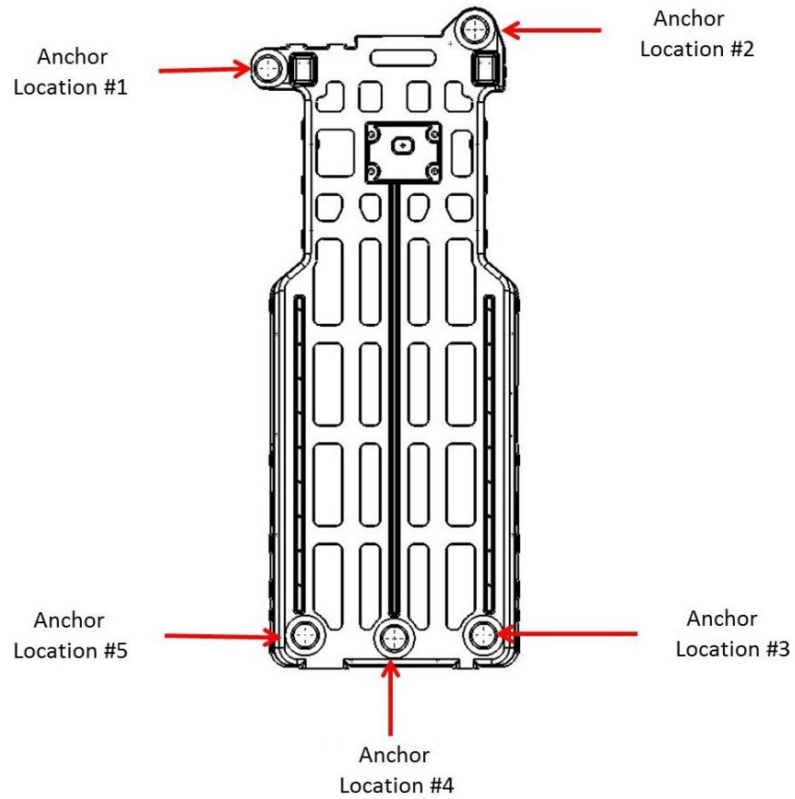

Table 13: Table and Gantry Seismic Anchoring Requirements

#	Mounting Requirement	Gantry	Table
1	Seismic Gantry Bushing	Included in Seismic Set	Included in Seismic Set
2	Seismic Gantry Washer	Included in Seismic Set	Included in Seismic Set
3	Washer Locking NL16sp	Included in Seismic Set	Included in Seismic Set
4	Seismic Anchor Type Recommended - Not Provided by Arineta	KB-TZ 5/8 in x 10 in	KB-TZ 5/8 in x 10 in
5	Maximum Distance after Proper Torque (a)	25.0 mm (0.98 in)	25.0 mm (0.98 in)
6	Initial Height from the Floor	25.0 mm (0.98 in.) +/- 5.0 mm (0.197 in)	25.0 mm (0.98 in) +/- 5.0 mm (0.197 in)
7	Nominal Embedment Before Anchor is Torqued	113.0 mm (4.45 in) minimum 63.0 mm (2.5 in)	113.0 mm (4.45 in) minimum 63.0 mm (2.5 in)
8	Recommended Drilling Depth	121.8 mm (4.91 in)	121.8 mm (4.91 in)
9	Minimum Floor Thickness	160.0 mm (6.25 in)	160.0 mm (6.25 in)
10	Drill Bit	5/8 in	5/8 in
<p>(a) The starting insertion depth is 13.0 mm (0.51 in), which is the set amount of threads exposed when the anchor is installed in the hole. The anchor is hammered into the hole with the nut and washer installed until the washer bottoms out on the anchor washer (item #5 above).</p>			

Use the following seismic installation methods and guidelines:

- Method 1 – Floor Concrete Thickness Greater Than 160 mm (6.25 in)

The minimum concrete floor thickness beneath the gantry and the patient table must be 160 mm (6.25 in) for a seismic site. See [Illustration 23](#).

Illustration 23: Concrete Thickness Greater Than 160 mm (6.25 in)

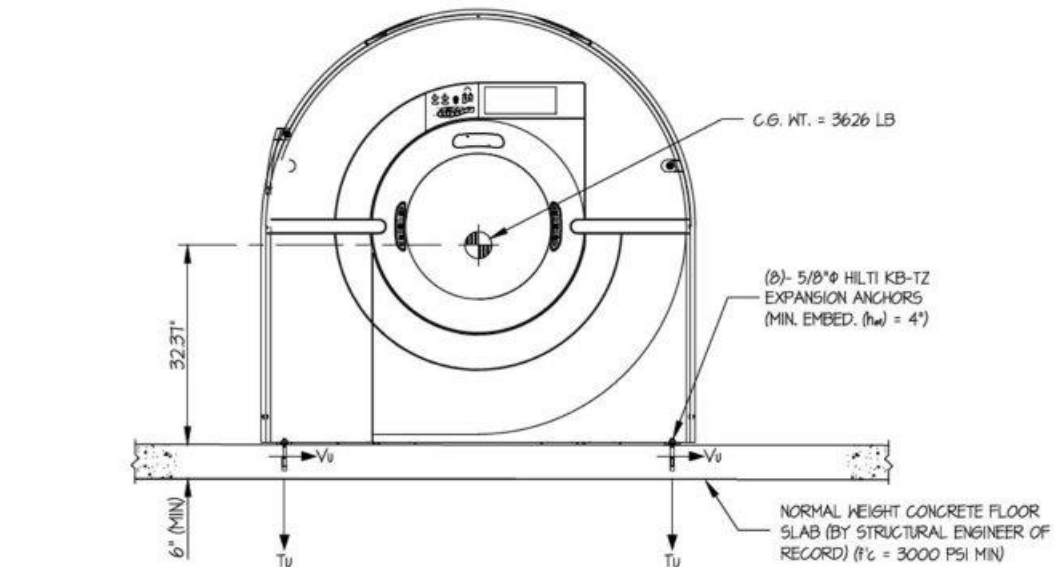

$T_u = 2066 \text{ LB/BOLT (MAX)}$
 $V_u = 654 \text{ LB/BOLT (MAX)}$

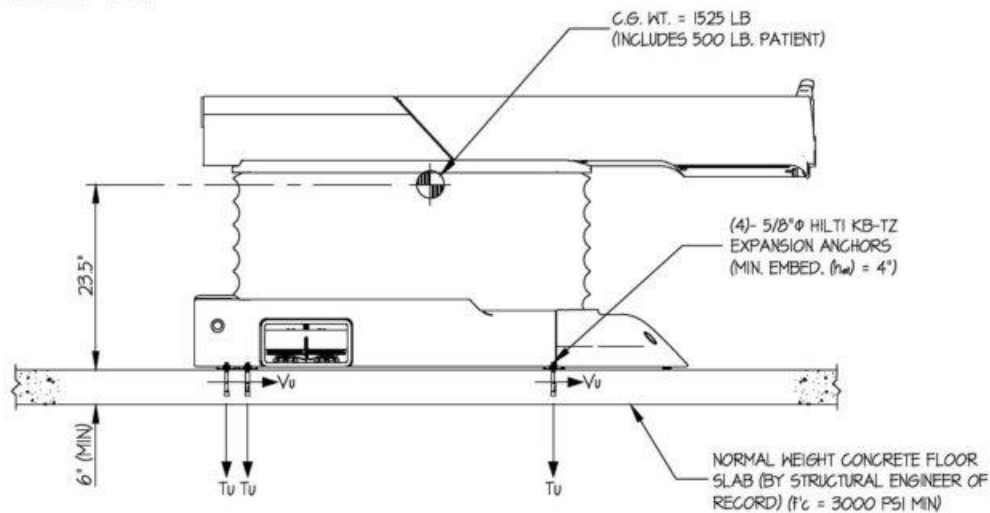

$T_u = 2083 \text{ LB/BOLT (MAX)}$
 $V_u = 583 \text{ LB/BOLT (MAX)}$

- Method 2 – Floor Concrete Thickness Less Than 160 mm (6.25 in)

The minimum concrete floor thickness beneath the gantry and patient table must be 160 mm (6.25 in) for a seismic site. If it is less than 160 mm (6.25 in), it is required to use a strut beneath the floor. See [Illustration 24](#).



NOTICE

The supporting strut beneath the floor must be provided by the customer.

Illustration 24: Floor Concrete Thickness Less Than 160 mm (6.25 in)

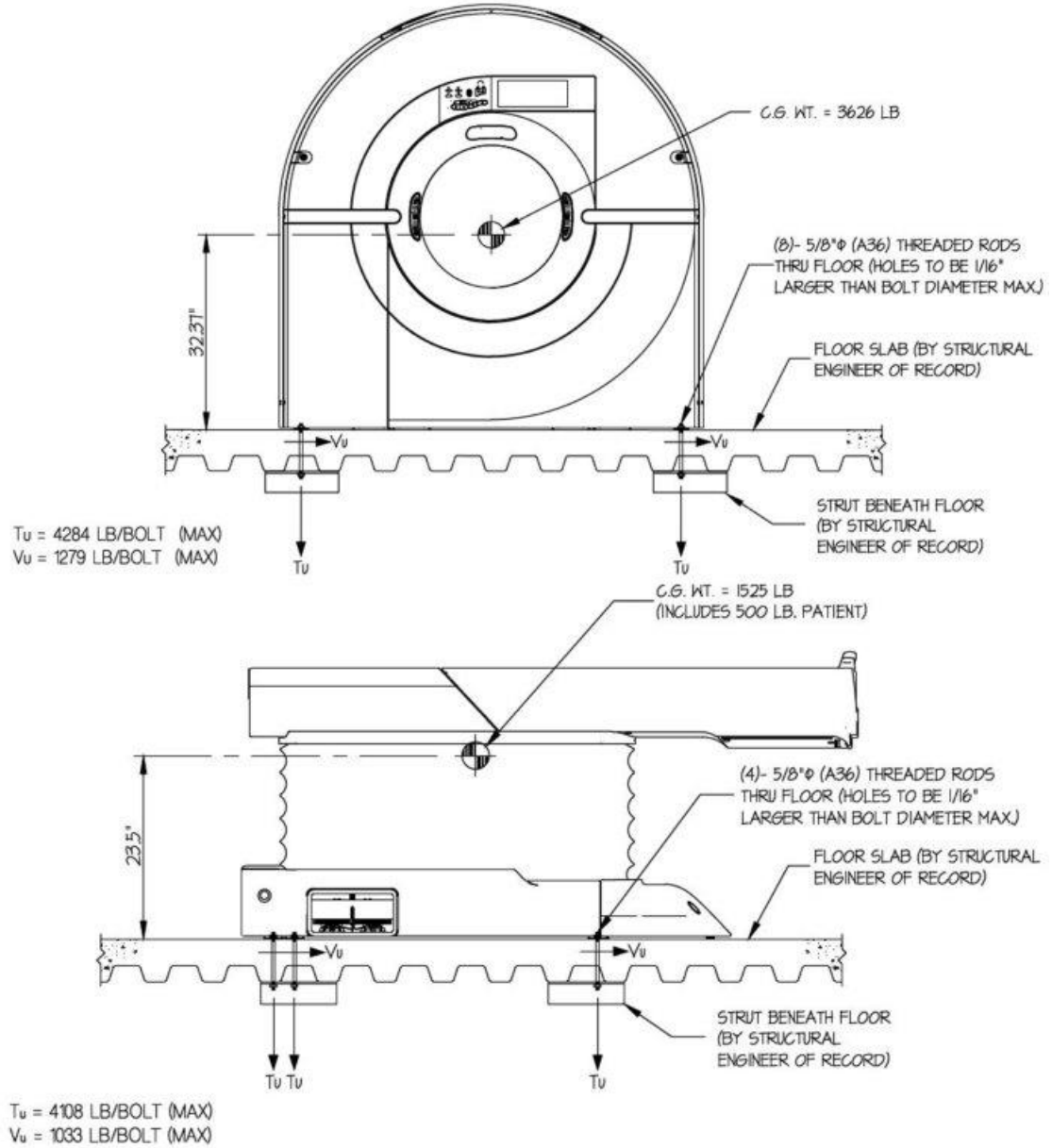

7.4.7.2 System Console Cabinet – Seismic Method

If site specifications require seismic mounting, use the System Cabinet shipping brackets as the seismic brackets.

Arineta does not supply anchors with the seismic kit. It is the responsibility of the customer to have qualified structural engineers to determine and supply the correct seismic anchors.

Illustration 25: Console Cabinet Seismic Anchor Location

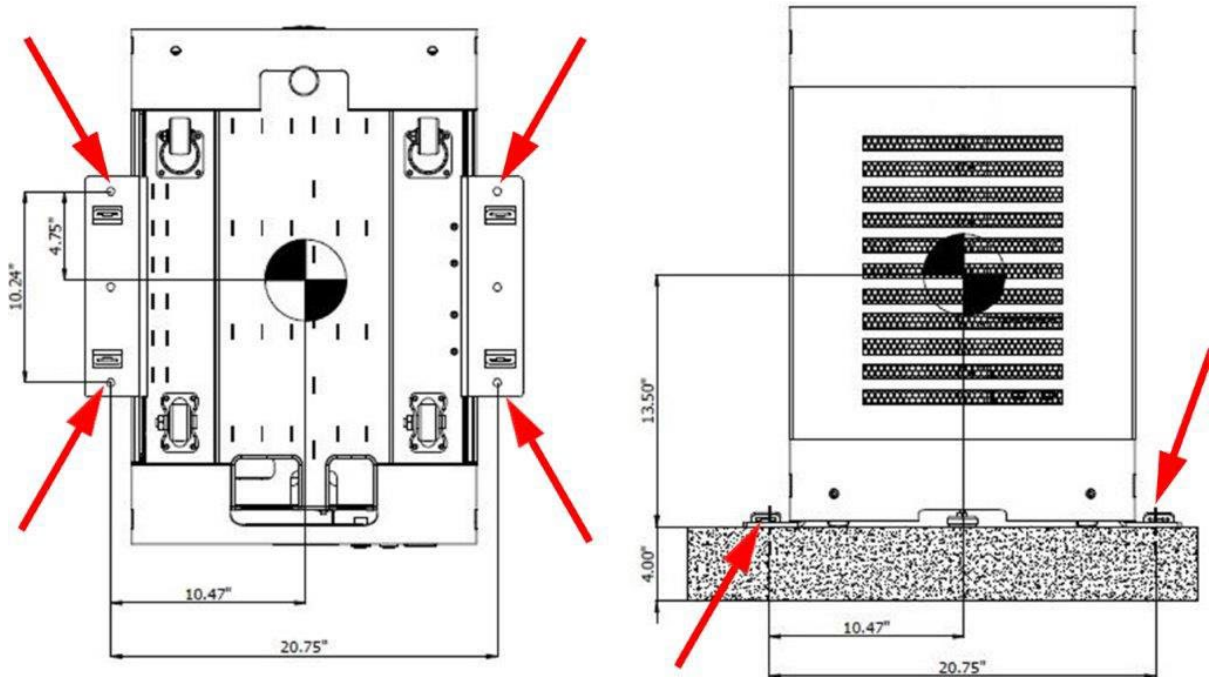

Table 14: Console Seismic Anchoring Requirements

#	Mounting Requirement	Console
1	Console Pack Bracket	Included in Console Pack
2	Seismic Anchor Type Recommended - Not Provided by Arineta	KB-TZ 3/8 in x 3-3/4 in
3	Maximum Distance after Proper Torque (a)	25.0 mm (0.98 in)
4	Nominal Embedment Before Anchor is Torqued	67.0 mm (2.64 in) minimum 51.0 mm (2.0 in)
5	Recommended Drilling Depth	77.9 mm (3.07 in)
6	Minimum Floor Thickness	102.0 mm (4.0 in)
7	Drill Bit	3/8 in
(a) The starting insertion depth is 13.0 mm (0.51 in), which is the set amount of threads exposed when the anchor is installed in the hole. The anchor is hammered into the hole with the nut and washer installed until the washer bottoms out on anchor washer (item #5 above).		

7.4.7.3 PDU – Seismic Method

If site specifications require seismic mounting, Arineta supplies the PDU bracket for seismic anchor installation as a purchased option. The PDU bracket for seismic anchor installation is included in the seismic kit (KIT-15940).

However, Arineta does not supply anchors with the seismic set. It is the responsibility of the customer to have qualified structural engineers to determine and supply the correct seismic anchors. Refer to [Illustration 26](#) for mounting hole locations to mount the PDU so that it can be easily removed for service.

Illustration 26: PDU Seismic Anchor Location

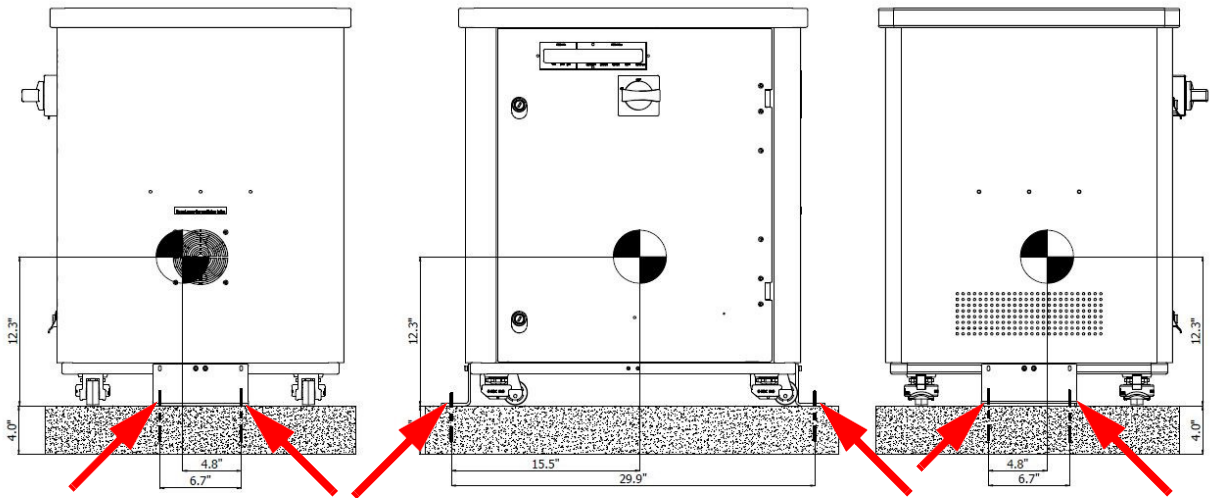

Table 15: PDU Seismic Anchoring Requirements

#	Mounting Requirement	PDU
1	PDU Pack Bracket	Included in Seismic Set
2	Seismic Anchor Type Recommended - Not Provided by Arineta	KB-TZ 3/8 in x 3-3/4 in
3	Maximum Distance after Proper Torque (a)	25.0 mm (0.98 in)
4	Nominal Embedment Before Anchor is Torqued	67.0 mm (2.64 in) minimum 51.0 mm (2.0 in)
5	Recommended Drilling Depth	77.9 mm (3.07 in)
6	Minimum Floor Thickness	102.0 mm (4.0 in)
7	Drill Bit	3/8 in
a) The starting insertion depth is 13.0 mm (0.51 in), which is the set amount of threads exposed when the anchor is installed in the hole. The anchor is hammered into the hole with the nut and washer installed until the washer bottoms out on anchor washer (item #5 above).		

Chapter 8 Room Sizes and Layouts

8.1 Functional Scan Suite Layout Configuration

A functional scan suite consists of a separate scan room and control room. The scan room contains the SpotLight system, and the control room houses the console assembly for operation of the system. Both must be designed with sufficient space to accommodate:

- All individual components of the SpotLight system.
- Service access to support the individual SpotLight system components.
- Operational egress to safely exit all areas of the rooms.
- All regulatory codes based on the location of the system.

The minimum control room and scan room sizes are based on the regulatory envelope that surrounds a CT scanner. This envelope of space includes the above considerations along with all regulatory requirements and applicable local building codes.

8.2 Room Dimensions

8.2.1 Scan Room Requirements

The minimum size for the scan room may vary. Factors to consider are:

- Room workflow
- Patient care accessibility
- Critical care equipment requirements
- Safety egress and door swing egress
- Possible future system option upgrades or purchases
- Local regulatory codes
- Cabinets
- Sink
- Medical gas access/clearances



NOTICE

A UPS is optional and is not a required factor for the list above. The manner in which items are configured in the scan room also has an impact, as described in Workspace Requirements [on page 68](#).

Table 16: Suggested Scan Room Size Dimensions

Suggested Room Size	Minimum Room Size Option A	Minimum Room Size Option B
6,000 X 5,000 mm * (236.2 in X 196.85 in)	4,404 X 3415 mm ** (173.4 in X 134.5 in)	4,350 X 4000 mm ** (171.3 in X 157.5 in)
* Typical dimensions, subject to site available space and needs.		
**All service/regulatory requirements apply.		

8.2.1.1 Suggested Room Size

The suggested room configuration provides both ample workspace and space for storage and additional equipment. When local regulations require a sink in the scan room, the room size should also provide sufficient space for a sink. This room size accommodates the needs of larger hospitals and medical teaching facilities, where patients may require transportation to the scan area in beds, gurneys and larger wheelchairs, and where they may require the assistance of larger medical care teams.

Likewise, this room offers adequate access for crash carts and other emergency medical equipment on both sides of the table. The suggested size supports all service activities, including tube change, and accommodates all future two-step installations.

8.2.1.2 Minimum Room Size

The minimum room size configuration represents the smallest functionally acceptable space for the SpotLight and represents the type of room often found at doctors' offices and smaller clinics and outpatient facilities.



NOTICE

The dimensions shown for the minimum room size assume a room configuration in which the front and gantry side covers are removed and stored. See [Service Clearance Requirements on page 68](#) for more details.

Due to its limited size as well as functional and regulatory requirements, the minimum room size usually provides only limited workspace, and leaves no space to add in-room furniture and sinks. The minimum room size must meet the necessary regulatory and service requirements. This room can accommodate the transportation of patients into the scan area using wheelchairs, and provides access for crash carts and other emergency medical equipment on only one side of the table. Sites considering a minimum room size may not have been designed with the structural requirements necessary to support the system and consequently may require upgrading prior to installation. Customers considering a minimum room size should discuss their workspace requirements with their PMI.

CAUTION



In a minimum room layout, the customer should consider the workflow, customer access for patient care and critical-care operational space requirements. Additionally, this room provides only limited equipment access on the gantry's left side when positioning patient equipment in the room between the gantry and the wall.

8.3 Suggested Room Layouts

The figures below show the recommended and typical room layouts. You must determine the locations for medical gas, surface duct work or other items that make a grounded wall.

The PDU may be positioned in the scan room or in an adjacent utility room.

Consideration should be given to the doors for patients' entrance and exit, and a utility door between the scan and control rooms. Patient access may be from a preparation area (not shown below). The table and gantry allow patient loading and gantry operation from either side of the table. Therefore, the patient door can be on either side of the room, depending on site considerations.



NOTICE

Your room layout may meet the recommended or typical room requirements, but appear differently than what is shown here. Your salesperson or PMI can suggest a detailed room layout for your site.

Illustration 27: Typical Room Layout

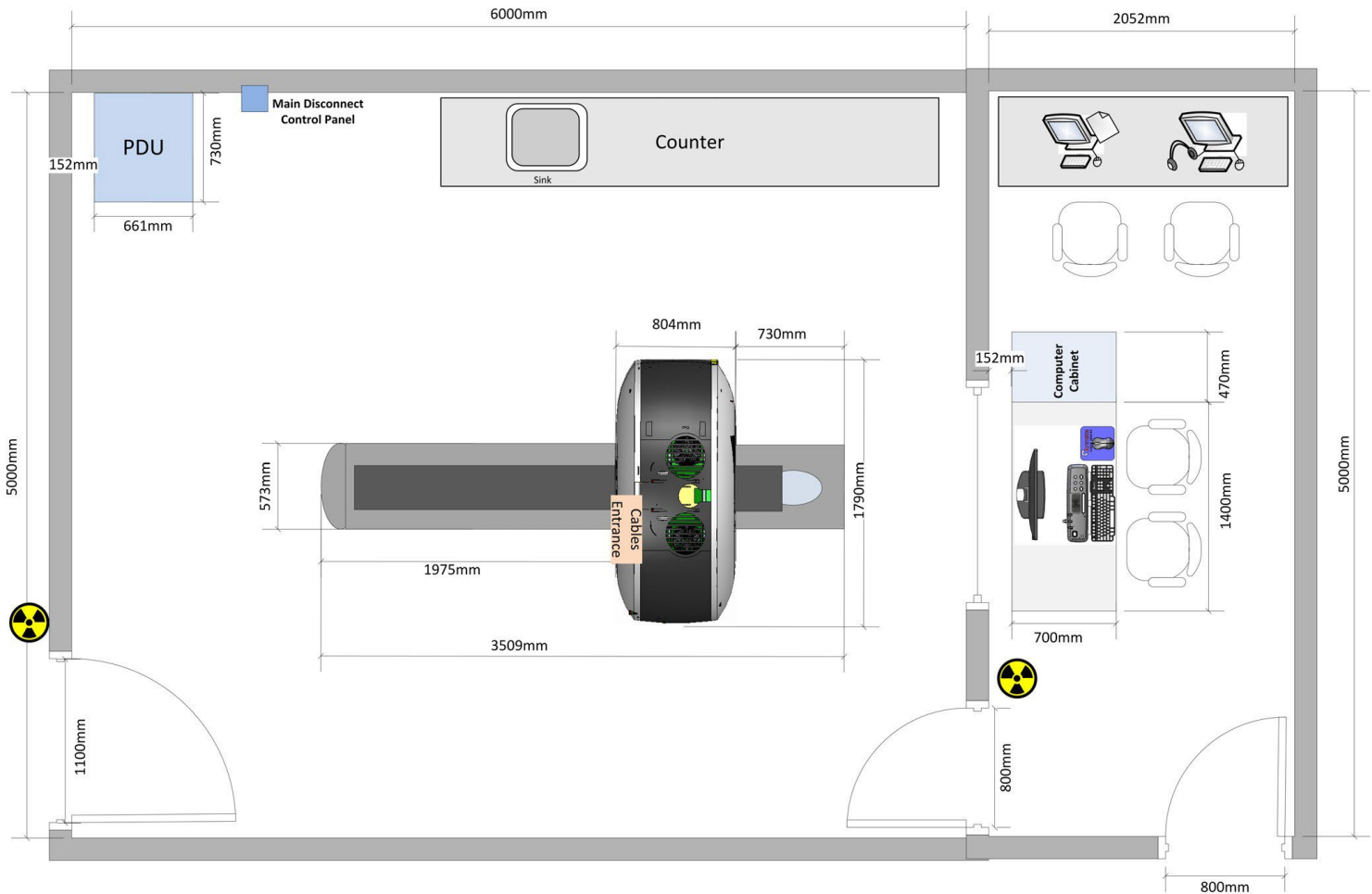
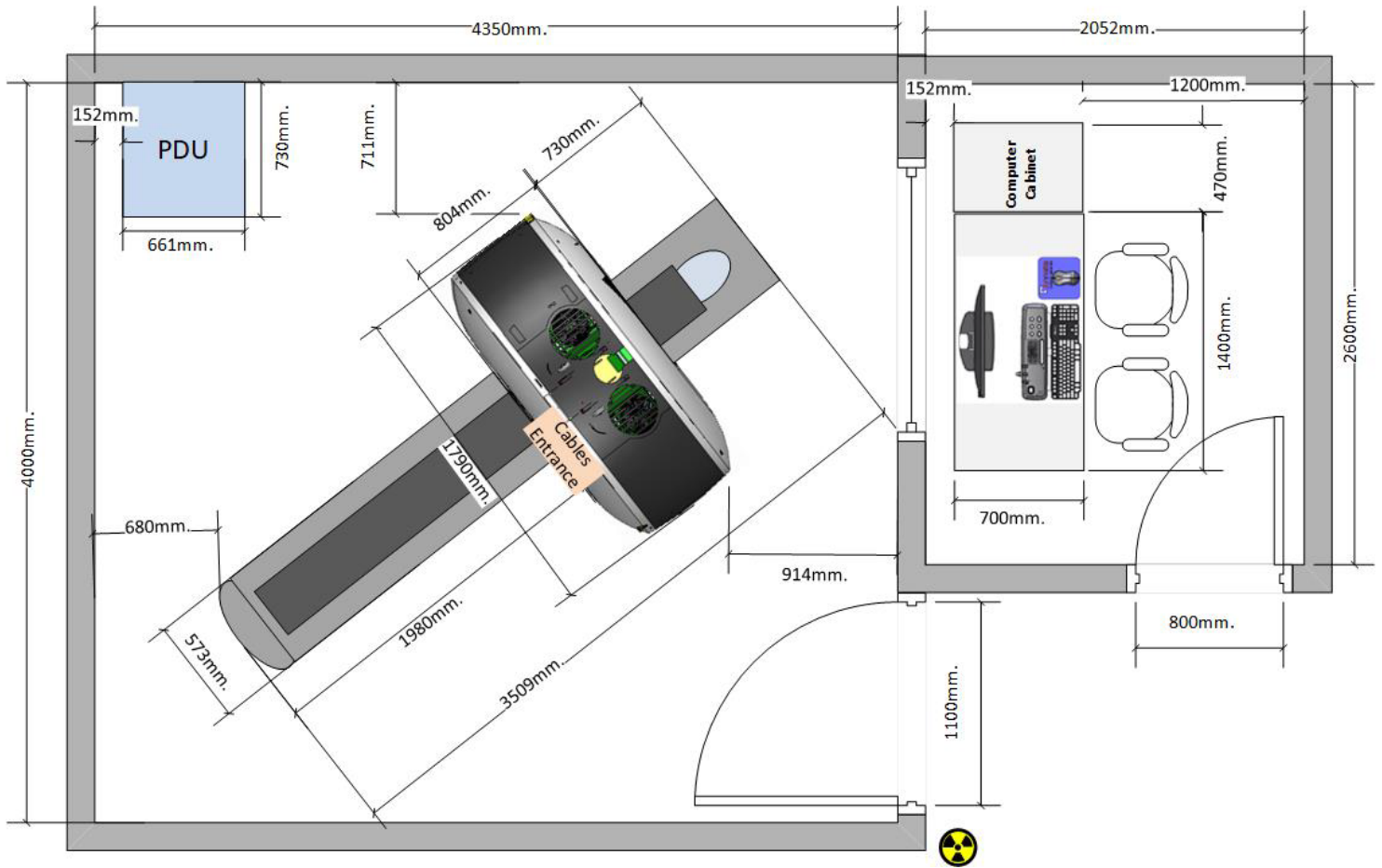

Illustration 29-A: Minimum Room Size – Layout B



8.4.1 Minimum Room Layout with RunOff option

The **RunOff** feature is a clinical protocol in which the patient is scanned from the legs up, in order to track Arteries. This feature is used with table cradle extender option which is added on the front side of the table. The table cradle extender is 350mm length, and its effect on the system installation space from the wall.

Illustration 28-B: Minimum Room Size with RunOff option– Layout C

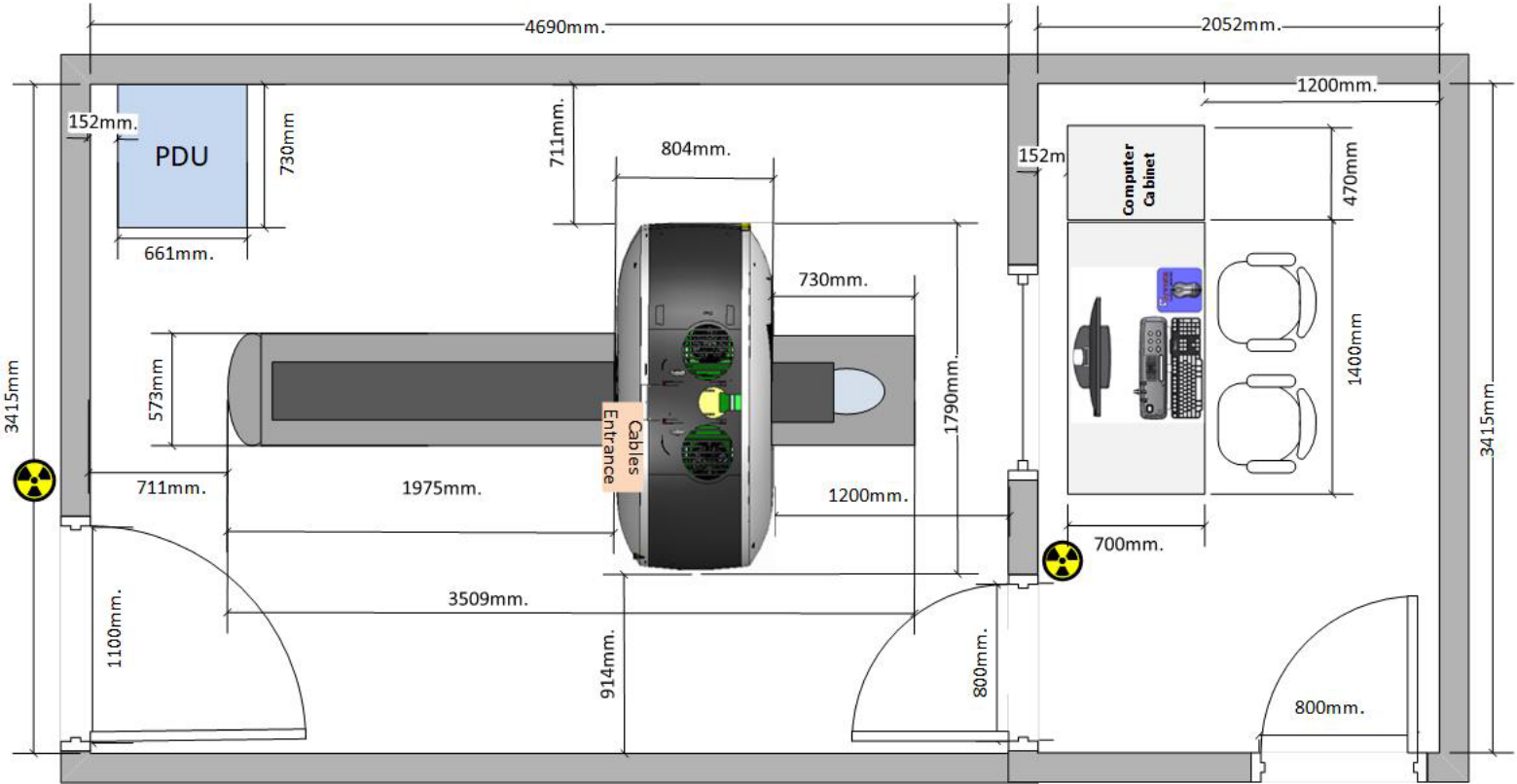
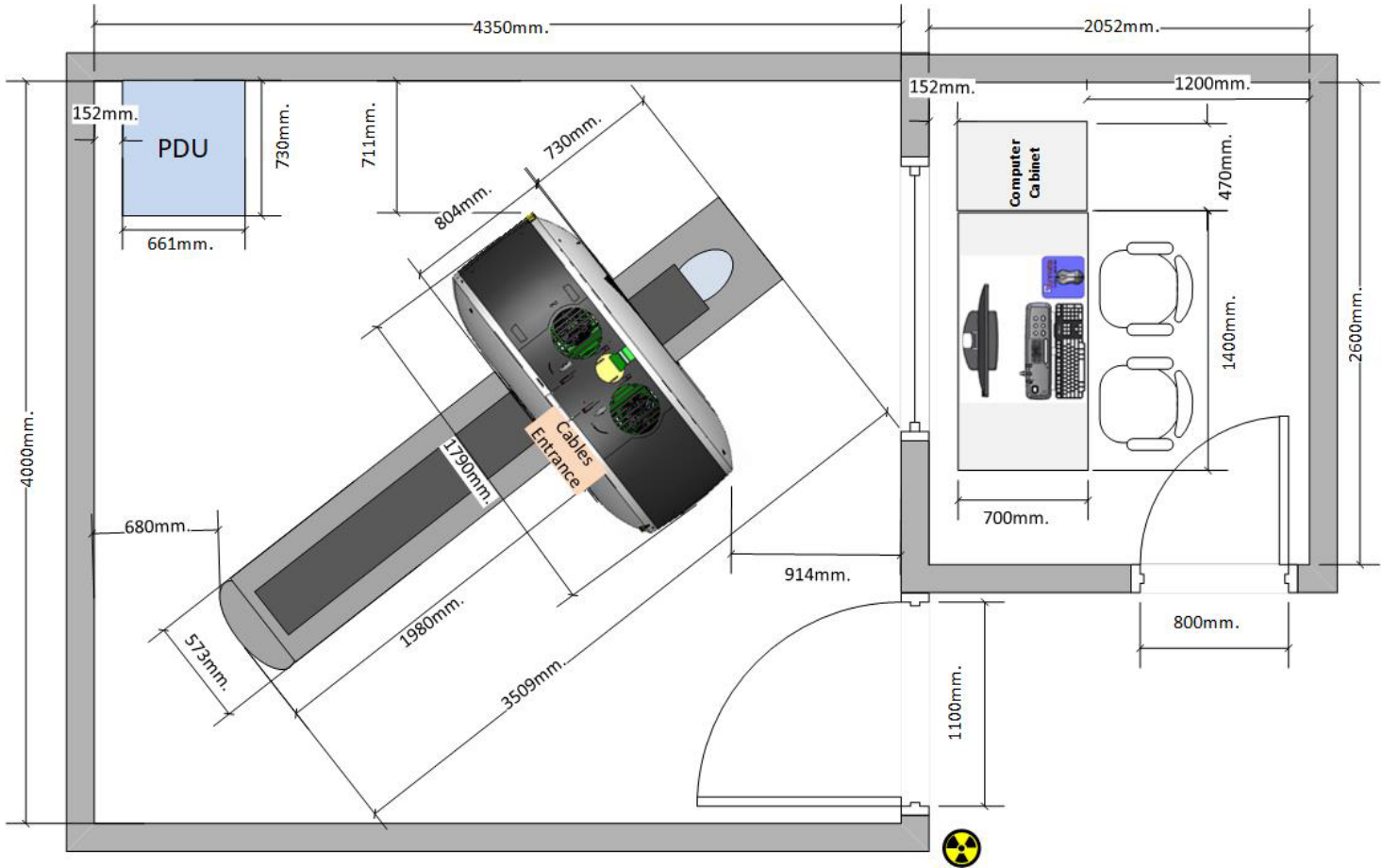

Illustration 29-B: Minimum Room Size with RunOff option– Layout D



8.5 Workspace Requirements

Prior to the delivery and installation of the system, ensure that there is enough room in the suite to receive and temporarily store all components and service equipment required for the installation. This includes all system components, subsystems and all subsystem components. If there is insufficient space, the PMI should work with the customer to arrange for temporary storage at a location as close to the suite as possible. This temporary location must meet the same temperature and humidity specifications as defined in Shipping and Receiving on [page 35](#).

8.5.1 System Configuration and Room Requirements for Workspace

8.5.1.1 Definitions:

- **Working Space:** Workspace for equipment operating at 600 Volts, nominal, or less, to ground, and likely to require examination, adjustment, servicing or maintenance while energized.
- **Service Space:** Defined as Working Space by NFPA 70e (Table 110.26) 2011 Edition. Arineta also requires a minimum workspace for the safe servicing of the product. This workspace is defined for situations when the cover has been removed or open in the area where service is performed, and power is applied to the system.

- **Grounded Surface/Wall:** Made of concrete, masonry, brick, ceramic tile or a wall that contains surface-mounted electrical boxes, conduits, medical gas or other exposed metal plumbing or ducting.
- **Ungrounded Surface/Wall:** Made of wood or other insulated construction material that does not create a path to ground when touched.
- **Obstructions:** Surface-mounted floor ducts or other trip hazards, walls, pilasters, support columns and equipment covers stored temporarily that may block direct access to an exit from the room.
- **Powered On Service– Workspace Egress - 711.0 mm (28.0 in):** Any workspace around the perimeter of the system or subsystem must have at least one unobstructed route to a direct exit of the room. The width of the exit route must not be less than 711.0 mm (28.0 in) along the entire length of the route. This emergency egress route must be free of obstructions and trip hazards, including equipment covers that may have been removed for service and surface floor ducts.
- **Small Room (Not Recommended):** A condition of installation where the gantry may be placed a minimum of 356.0 mm (14.0 in) from a wall where access to electrical power or the wall is not required. The 356.0 mm (14.0 in) condition may be applied to both sides of the gantry, providing that doing so does not create a trapped area or inhibit direct unobstructed safe egress from the scan room with a minimum width of the egress path of no less than 711.0 mm (28.0 in). From the end of the patient table to the wall should be at least 152.4 mm (6.0 in).

In accordance with NFPA 70e (Table 110.26) 2011 Edition, Arineta requires the following minimum workspace requirements for the safe servicing of the product.

- Workspace clearances apply to equipment operating at 600 V or less, where examination, adjustment, servicing and maintenance is likely to occur with live parts exposed.
- System servicing requires a space for one service engineer to accomplish all system component replacement and service tasks. There must be sufficient workspace in the scan room to allow adequate egress during service operations.
- If the customer and PMI have any concerns that the site does not provide adequate workspace for egress under these conditions, the necessary provisions should be made to accommodate this event.
- The customer must maintain the required regulatory clearance distances and not use these areas for storage. This applies during normal system operation and during service inspection and routine maintenance.
- It is important to review operational clearances in order to verify that daily-use items properly fit (beds, carts, wheelchairs and so on). In addition, it is also necessary to consider clearances for emergency medical equipment.

Illustration 30-A: Regulatory Clearance Requirements for the SpotLight System

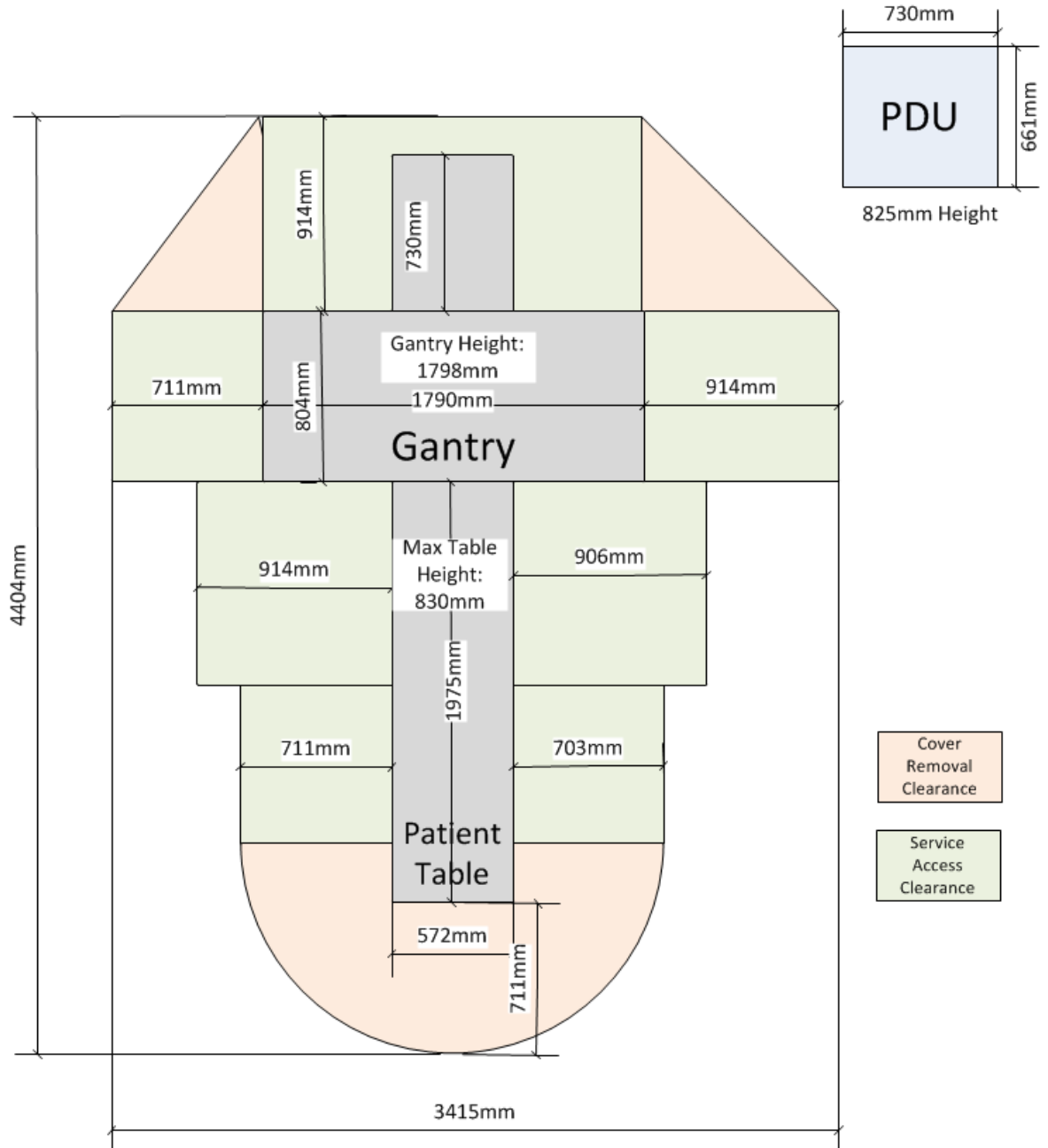

NOTICE

see Regulatory Clearance Requirements for the SpotLight System with Runoff configuration in illustration 30-B

Illustration 31-B: Regulatory Clearance Requirements for the SpotLight with RunOff (ECOV) System configuration

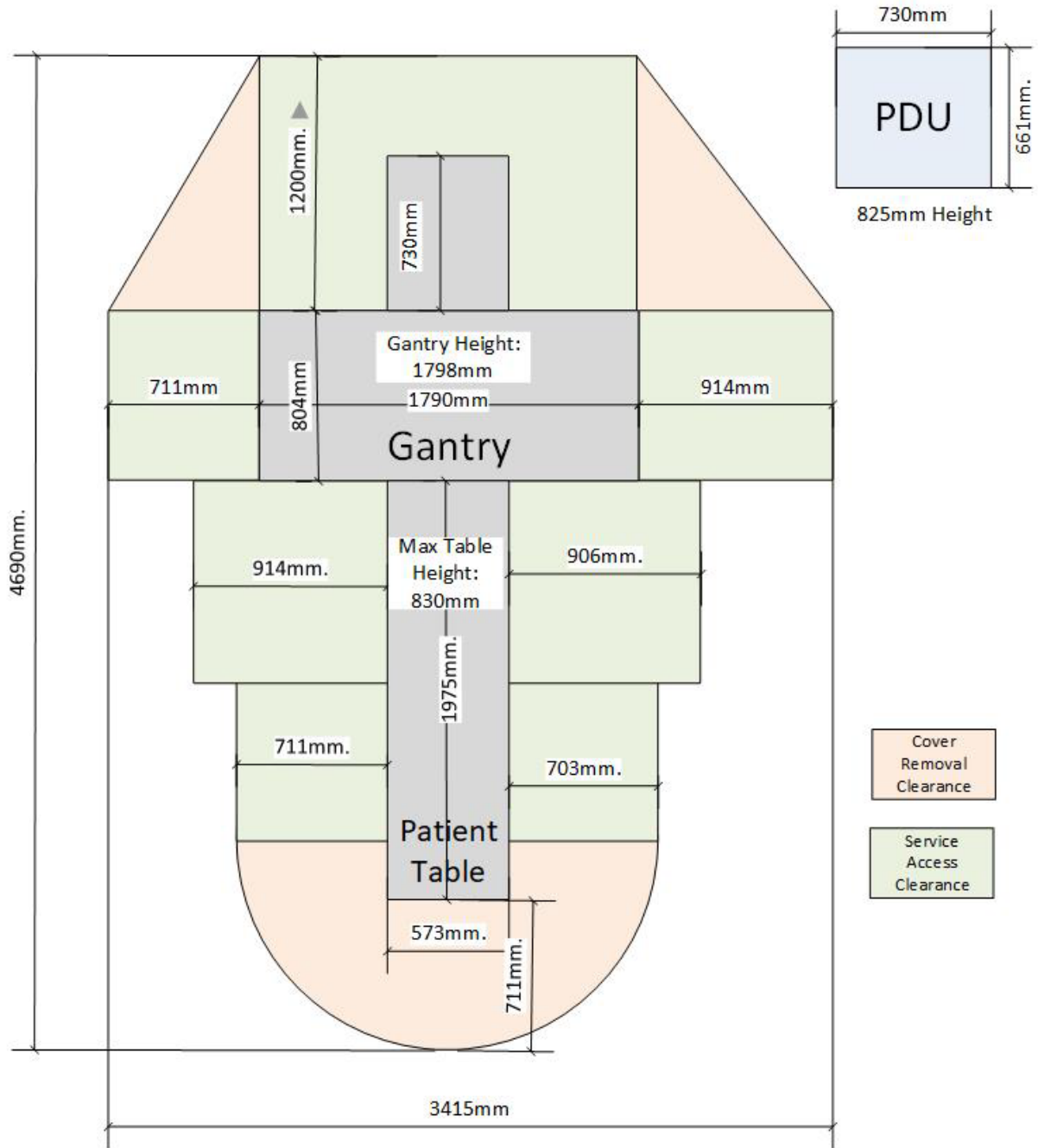

Table 17: Minimum Ceiling Height Requirements

Unobstructed Hallway Heights	2,134.0 mm (84.0 in)
Doorway opening heights	1,850.0 mm (73.0 in)
Above Table and Gantry	2,286.0 mm (90.0 in)*
Head clearance in front of the gantry when overhead equipment is installed	1,981.0 mm (78.0 in)**
* Or the minimum distance allowed by local laws and codes, whichever is greater.	
** Or the height of the equipment, whichever is greater.	

Table 18: Workspace Definition

Dimension	Condition	Separation Distance mm (in)
Length/Depth	If the depth of the workspace is directly facing an ungrounded surface or wall without live voltage panels (less than 600 V) and without surface-mounted ducts or conduits.	914.0 (36.0)
	If the depth of the workspace is directly facing a grounded surface or wall (less than 600 V).	1,067.0 (42.0)
	If the depth of the workspace is directly facing a surface or wall with live voltage panels (less than 600 V), grounded surface-mounted ducts or conduits.	1,219.0 (48.0)
Width	Minimum width of the workspace in front of the electrical equipment, unless the width of the exposed electrical equipment is larger.	762.0 (30.0)
	If the exposed electrical equipment is wider than 762.0 mm (30.0 in), the width of the equipment is the width of the workspace.	Size of Equipment
	The workspace must permit at least a 90-degree opening of equipment doors.	
Height	The minimum height of the workspace must be clear and extend from the grade (floor), unless the height of the equipment is higher.	1,981.0 mm (78.0 in)
	If the equipment is taller than 1,981.0 mm (78.0 in), the required height of the workspace is the height of the equipment.	Height of Equipment

⚠ CAUTION



All system installations, relocations and moves require site prints. The CT room layout must match the layout shown on your site print and meet all regulatory requirements described in the ARINETA SPOTLIGHT INSTALLATION MANUAL.

All system installations, relocations and moves require site prints. The CT room layout must match the layout shown on your site print and meet all regulatory requirements described in the ARINETA SPOTLIGHT INSTALLATION MANUAL.

Actual site measurements obtained by the mechanical installer before installation determines room size and compliance.

8.6 NEC Conduit and Duct Fill Rate

The required workspace has several conditions defined by the (U.S.) National Electrical Code (NEC) and is adopted by Arineta as the minimum siting conditions for all CT scanner installations. These conditions are defined by the wall type and accessibility/exposure to electrical power panels, electrical outlets, surface-mounted conduits, plumbing, hospital gases or surface ground points directly opposite exposed CT equipment.

Full operation, service and safety of the system require the maintenance of sufficient regulatory and service clearances around equipment.

Cable length is an important consideration in the room layout. The SpotLight system ships with standard-length (short) cables, with a set of longer cables available as an option. For more details, see Power and System Connections [on page 85](#).

The following rules govern cable usage for the system:

- Do not cut or otherwise shorten long cables.
- Do not store excess cable length behind the operator console cabinet, gantry or PDU.
- Store excess cable in walls or floor ducts, if preferred, provided that sufficient space exists. Refer to NEC code to determine cable fill rates for conduits and ducts.
- All installed systems must comply with NEC 70-E electrical regulations governing conduit or duct fill.

8.7 Control Room Considerations

8.7.1 Control Room Requirements

The minimum size of the control room may vary due to factors such as the room workflow, size of the counter or furniture used to position the monitors, keyboard and other console assembly equipment. A clear line of sight from the operator workstation (monitor/keyboard) to the patient's face on the table is required in the scan room. The operator must be able to see the patient during the scanning process while at the operator workstation, in case of patient distress.

The control room must provide an operating environment suitable for the operator's console cabinet electronics and the operator's working comfort. Means for visual monitoring of the patient during the scan must be provided. Typically, this is achieved by a radiation-shielded window between the control room and the scan room. When using SpotLight system, the patient is positioned on the table in the "head in" position. In most scanners, the patient's head is at the front side of the gantry (the side opposite to the table) during scanning. Therefore, the viewing window should face the front of the gantry.

As the console cabinet requires adequate venting, maintain 152 mm (6 in) of clear, unobstructed space on all sides of the console to allow the fans located on the rear of the console to exhaust air. Provide a suitable work area within reach of the operator for the placement of the injector control on the operator's table. Injector controls differ in dimensions, depending on the brand selected.

The console assembly is powered from the system PDU. A PACS, workstation, image printer or filming device may be available in the control room area. These devices or other components, though having a direct link to the operator console via network or Ethernet cable or to the LCD display via USB 2.0, must not receive power from the CT operator console. When using additional devices or components, consider additional room power and network connections when reviewing the operator console workspace.

Illustration 32: Typical Control Room Layout

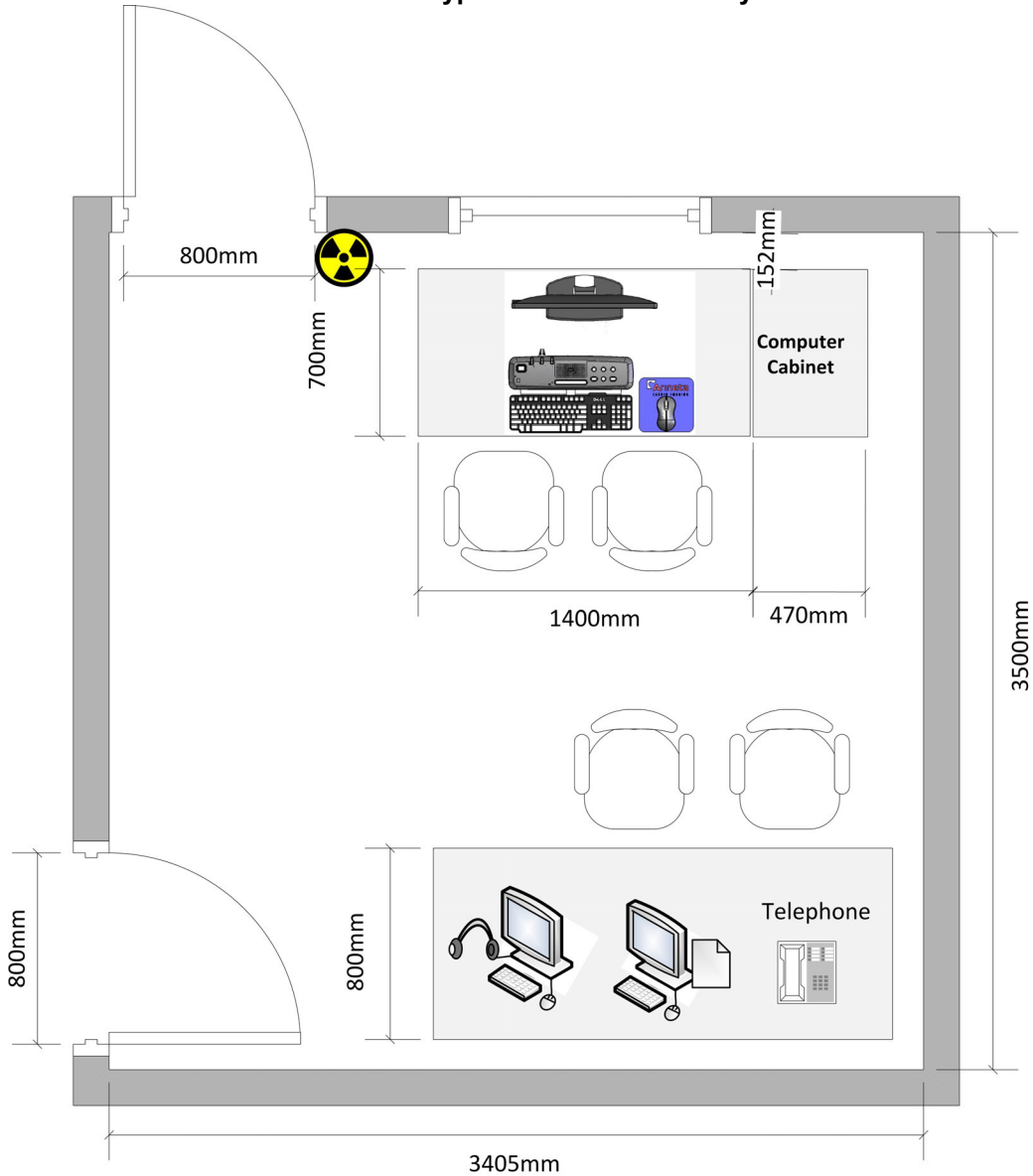

8.8 Service Clearance Requirements

8.8.1 Scan Room Subsystem Clearance Requirements

Some subsystems require removal of the covers for service. Make sure that there is sufficient space to remove all necessary covers from the subsystems.

System servicing requires sufficient space to remove the covers from the system. It also requires one service engineer to be able to accomplish all service component replacement tasks. All room layouts must provide service space and access around the table to the gantry's left side. This is needed for replacement procedures that require components that ship in large boxes, such as the Tubes, the DMS, the Grid and HV generators.

8.8.2 Gantry Cover Removal

Gantry front and rear cover removal requires the use of a minimum clearance space of 600 mm (24 in) to maneuver the cover away from the gantry.

Illustration 33: Gantry Front Cover Removal

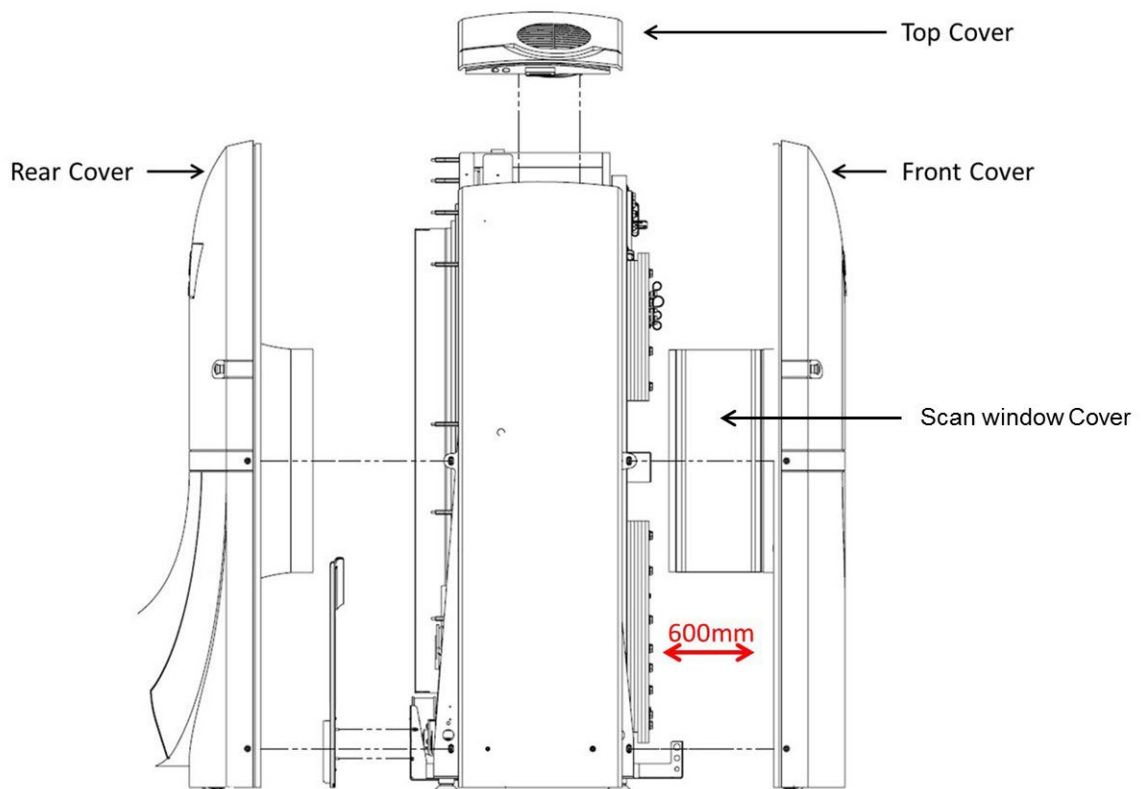

The front cover can be removed in the minimum room size as long as while there is 914 mm (36 in) space to the wall.



NOTICE

For removing the front cover in a minimum room size, the scan window cover must be disassembled from the front cover, making the front cover width 230 mm, so that it can be moved aside from the gantry. Then, the scan window cover can be disassembled from the rear gantry cover and removed to provide more service access to the gantry parts.

Illustration 34: Gantry Sides and Top Covers

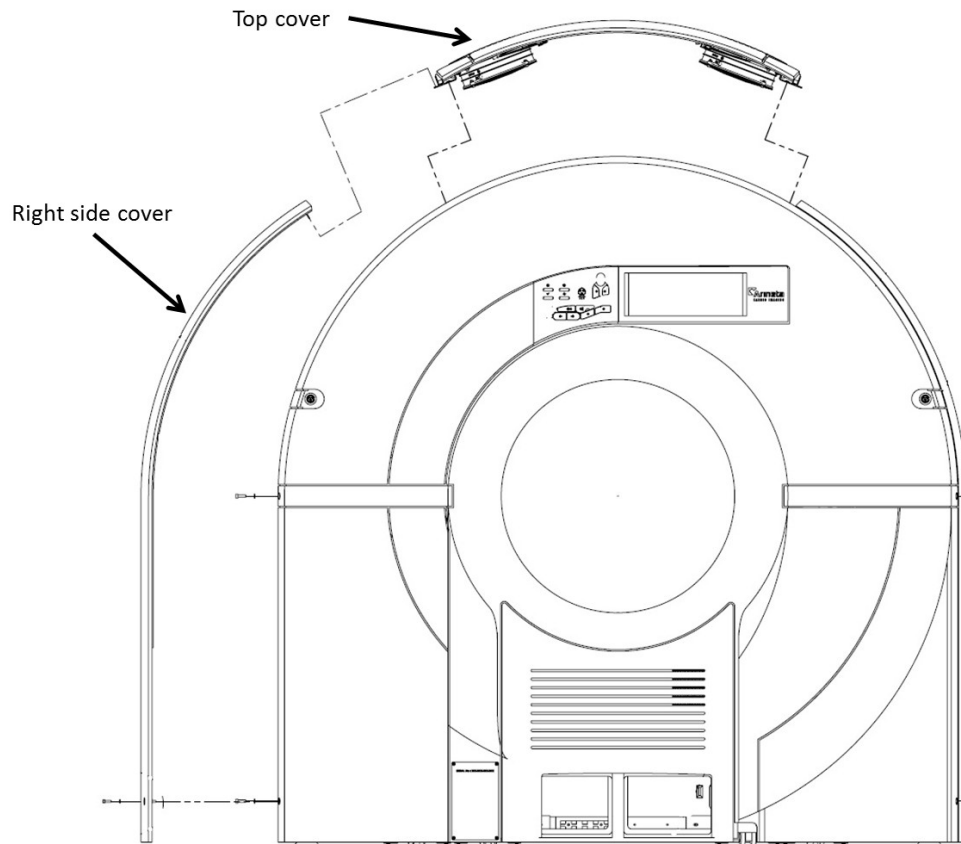
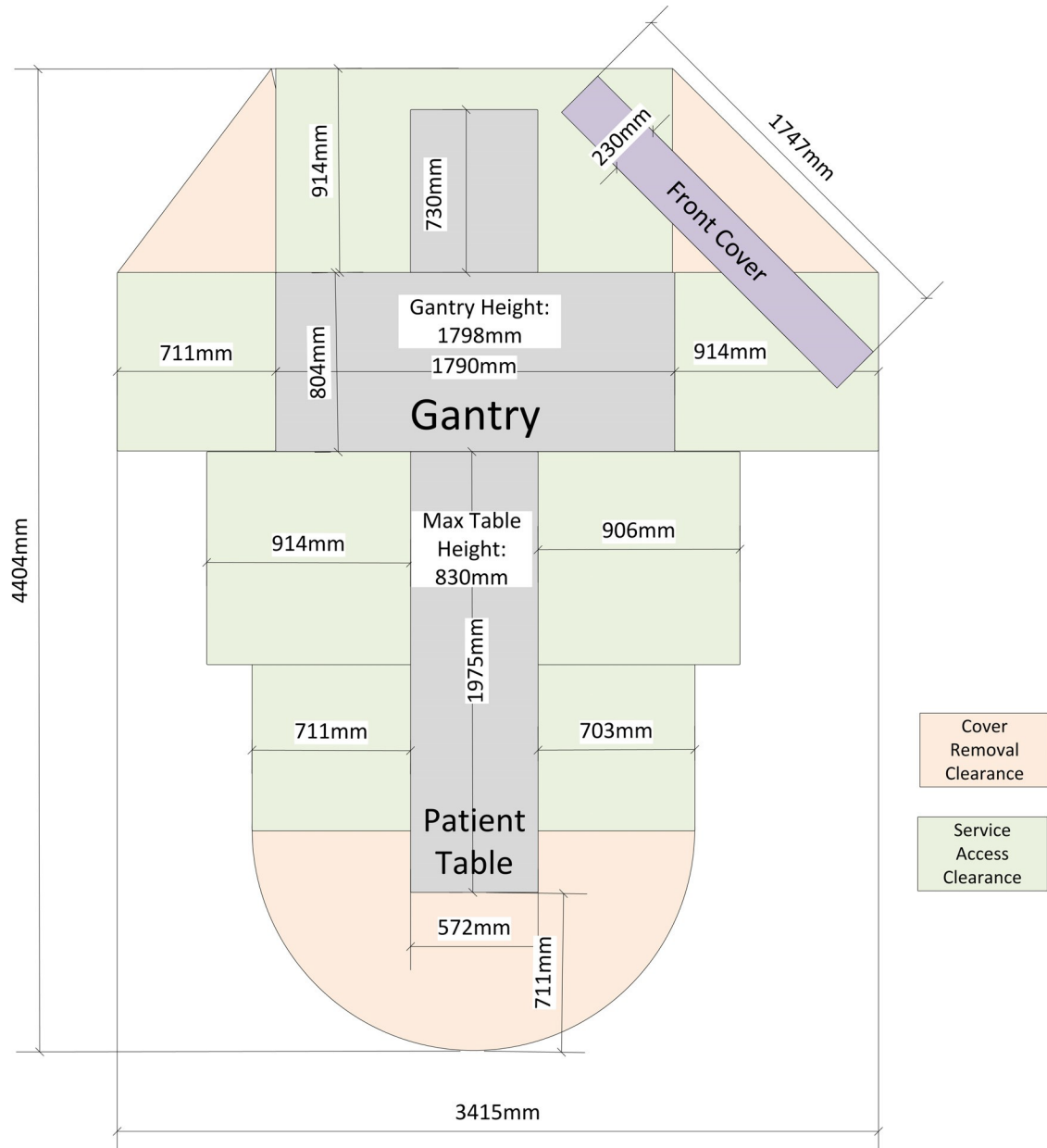

Illustration 35: Front Cover Removal in a Minimum Room Size



In cases where it is not required to remove the front cover in a minimum room size, it is recommended to remove the front cover while the scan window cover is attached to it, in order to provide more service access to the gantry parts.

The gantry rear, sides, top covers and table covers do not have any special requirements beyond the clearance required by regulations.

The following describes clearance considerations for an X-ray tube replacement example. The tube is delivered to the scan suite in a self-contained shipping crate that measures 700 mm (27.6 in) x 1020 mm (40.2 in) x 490 mm (19.3 in). It is critical that the area in front of the scanner allows room for this shipping container, as the replacement X-ray tube requires the use of the container. Also, consider the entire route that must be taken to position the tube crate for tube replacement, including the space required to move the crate past the table and wall or unmovable counter tops that may be present.

8.9 Power Distribution Unit (PDU)

When positioning the PDU, consider regulatory compliance. Also, refer to the room layout diagram in [Illustration 28](#). The PDU is on wheels and can be moved around for service.

Be sure to consider the future replacement of the PDU when positioning them in the scan room. Ensure that there is adequate space to move for replacement purposes.

8.9.1 UPS Space Requirements (Optional)

The optional UPS can be placed in the scan room or placed in another room providing that the cables are long enough and the environmental and HVAC requirements of the room equal or exceed the environmental and HVAC requirements of the scan room.

8.10 Control Room Console Assembly Requirements

- The site must maintain a service working clearance in front of the console assembly components, with a minimum depth of 914.4 mm (36.0 in).
- A clear line of sight from the operator workstation (monitor/keyboard location) to the patient on the table in the scan room is essential. The operator must be able to see the patient during the scanning process while at the operator workstation, in case of patient distress.
- The operator's area requires enough space for the console assembly components, including:
 - One 585.0 mm (23.0 in) LCD monitor
 - Computer mouse
 - Scanner Control Interface
 - Keyboard
 - Injector LCD monitor
 - Bar Code Reader (optional)
- At the rear and sides of the console cabinet, a minimum of 152 mm (6 in) of clear, unobstructed space must be maintained to allow for hot-air venting. The console cabinet is mounted on wheels, in order to provide sufficient rolling space to access the rear of the console cabinet during service. Refer to System Dimensions and Weight [on page 29](#) for the specific dimensions of these components.
- The console cabinet cables must remain as shipped. Cables cannot be cut or lengthened to relocate the monitor to a remote table or counter.
- No other electrical devices may be connected to the console cabinet. All other devices must be connected to their own electrical outlet or power source.

8.10.1 Operator Workspace Table (Optional)

- If the optional operator workspace table is used, the table must be located directly in front of the window between the control room and scan room, in order to provide the operator with a clear view of the patient laying on the table in a scan position. The items listed above must be placed on the desk surface.
- A clear line of sight from the operator workstation (monitor/keyboard location) to the patient on the table in the scan room is essential. The operator must be able to see the patient during the scanning process while at the operator workstation, in case of patient distress.

8.11 Verify Site Print

The customer shall ensure that all equipment, storage cabinets, counter tops and sinks appear on the site print, in their proper location. The provided drawing shall not be used as the “As-build” site print. It is intended to be used as a reference for the creation of the actual site print designed for the installation of the system.

Chapter 9 Electrical Requirements

9.1 Power Requirements

9.1.1 Certified Electrical Contractor Statement

All electrical installations that are preliminary to the positioning of the equipment at the site prepared for the equipment must be performed by a qualified licensed electrical contractor. In addition, electrical feeds into the PDU must be performed by a qualified licensed electrical contractor.

Other connections between pieces of electrical equipment, calibrations and testing must be performed by qualified Arineta personnel or by a person or persons trained by Arineta for the purpose of installing, uninstalling, moving, servicing and maintaining the SpotLight system. The products involved (and the accompanying electrical installations) are highly sophisticated, and special engineering competence is required. In performing all electrical work on these products, Arineta uses its own specially trained field engineers. All of Arineta's electrical work on these products complies with the requirements of the applicable electrical codes. The purchaser of Arineta equipment must only utilize qualified personnel (for example, Arineta's field engineers, personnel of third-party service companies with equivalent training or licensed electricians) to perform electrical servicing of the equipment.

9.1.2 Regulations

All electrical work must comply with NFPA 70E: Standard for Electrical Safety in the Workplace.

9.1.3 Disconnects

The customer must provide a main disconnect panel that meets the following requirements, in order to isolate the CT system from facility mains for service:

- **Emergency Off Switch**

The main disconnect panel must provide over-current protection for the entire system and must have at least one Emergency OFF switch located in the path between the operator's location and the patient (NEC 517.72b).

- **Local Disconnects**

The main disconnect panel with lock-out and tag-out (LOTO) capability must be installed within the scan suite (IEC60601-1 3.1, OSHA Title 29 CFR, and the National Electrical Code NFPA 70).

- **Neutral Wire**

Neutral Wire Not Necessary: If present, the neutral wire may be terminated at the main disconnect panel.

- **Dedicated Feeder**

A dedicated main disconnect panel must be used to supply power to the scanner. The main disconnect panel must be located in the same room as the PDU.

- **Protective Disconnect Device**

The protective disconnect must be located within 10 m (32 ft) of the PDU and be visible to personnel servicing the PDU.

- **Internal Disconnect**

The PDU contains the circuit breaker to provide an internal disconnect to isolate all three phases of the main disconnect panel's mains supply.

9.2 System Input Power

9.2.1 Electrical and Junction Boxes

- All electrical boxes and junction boxes must be installed as specified by the architectural, mechanical or electrical drawings associated with the design of the site.

9.2.2 Power Feed and Over-current Requirements

- **Power Feed:** The system must operate on a three-phase electrical power supply input provided by the customer, in 3 wire delta plus ground or 4 wires wye plus ground , the neutral line of the wye input will be connected to MDP GND. Qualified personnel must verify the power transformer and feeder lines (at the point of take-off) leading to the CT scanner, and meet all requirements stated in this document.

Table 19: Power Supply Requirements

Ground Points	Description
Power Supply	Three Phases + G 380/400/420/440/460/480 V +/- 10%
Frequencies	50/60 Hz +/- 3 Hz
Maximum Power Demand	75 kVA
Average (Continuous) Power Demand at Maximum Duty Cycle	10 kVA
Power Factor	0.85

- **Under-voltage Release Control:** The preferred disconnect utilizes an under-voltage release control, rather than shunt trip devices.
- **Over-current Protection:** To prevent power loss to other loads during an unexpected system fault, the power feeder must have over-current protection such that the downstream over-current protection devices clear the fault before an upstream over-current protection device opens.
- **Voltage Regulation:** To minimize, keep power wiring between the facility main disconnect panel and the PDU as short as possible.
- **Load Regulation:** Measured at the PDU input terminals. It must not exceed 6%.

9.2.3 Phase Imbalance

The difference between the highest line-to-line voltage and lowest line-to-line voltage must not exceed 2% of the lowest line-to-line voltage.

9.2.4 Sags, Surges and Transients

Sags and surges of the power line must not exceed the absolute range limits described below.

Table 20: Nominal Line Voltage and Current Ranges

Nominal Line Voltage Must Fall Within One of These Ranges					
Nominal Line Voltage (VAC RMS)	380	400	420	440	480
Hi-Line Limit, +10% over 24-hour period (VAC RMS)	418	440	462	484	528
Lo-Line Limit, -10% over 24-hour period (VAC RMS)	342	360	378	396	432
Continuous Line Current	20	19	18	17	16
Momentary Line Current	160	152	145	138	127
Maximum Line Current	176	167	159	152	139
Minimum Recommended Circuit Protection Rating A	80	80	80	80	80

9.2.5 Dedicated Power Source

It is recommended that a dedicated (feeder) supply power to the CT scanner.

The minimum recommended size for the dedicated power source is 75 kVA, rated 2.4% regulation at a unity power factor. The resulting maximum allowable feeder regulation is 3.4%. Do not use an existing distribution transformer to power a system if other X-ray equipment, using rapid film changers, is connected to the existing transformer.

9.2.6 System Power Requirements

The customer must ensure that the site meets all the minimum system power requirements listed below before installation can begin:

- Maximum power demand basic system with 72kW generator = 115 kVA for 4 sec.
- Continuous (average) power demand at maximum duty cycle = 10 kVA.
- Maximum allowable total source load regulation is 6%.

9.2.6.1 Supply Characteristics

- Power input must be separate from any others that may generate transients (elevators, air conditioning, radiology rooms equipped with high-speed film changers and so on).
- All equipment (lighting, power outlets and so on) installed with Arineta system components must be powered separately.
- The phase imbalance is 2% maximum.
- Transients must be less than 1,500V peak (on a 400V line).

Table 21: Minimum Feeder Wire Size

Feeder Length	Minimum Feeder Wire Size, AWG or MCM (sq. mm)/ VAC				
	380 VAC	400 VAC	420 VAC	440 VAC	480 VAC
Power Substation to Main Power Disconnect Panel					
15 m (50 ft)	4 (25)	4 (25)	4 (25)	4 (25)	4 (25)
30 m (100 ft)	4 (25)	4 (25)	4 (25)	4 (25)	4 (25)
46 m (150 ft)	4 (25)	4 (25)	4 (25)	4 (25)	4 (25)
61 m (200 ft)	4 (25)	4 (25)	4 (25)	4 (25)	4 (25)
76 m (250 ft)	3 (30)	3 (30)	4 (25)	4 (25)	4 (25)
91 m (300 ft)	2 (35)	2 (35)	3 (30)	3 (30)	4 (25)
107 m (350 ft)	1 (45)	2 (35)	2 (35)	3 (30)	4 (25)
122 m (400 ft)	1 (45)	1 (45)	2 (35)	2 (35)	3 (30)



NOTICE

In all cases, the minimum requirement for the SpotLight system is 4 (25)sq.mm; however, the Arineta recommended ground is 1 (45)sq.mm.

Table 22: Minimum Subfeeder Wire Size

Subfeeder Length	Minimum Feeder Wire Size, AWG or MCM (sq. mm)/ VAC				
	380 VAC	400 VAC	420 VAC	440 VAC	480 VAC
Main Power Disconnect Panel to PDU					
10 m (33 ft)	4 (25)	4 (25)	4 (25)	4 (25)	4 (25)

The information in the table above assumes the use of copper wire, rated 75°C and run in a steel conduit. All ampacity is determined in accordance with the National Electrical Code (NFPA 70), Table 310-16 (2002). The ampacity of the circuit protection device listed above determines the minimum feeder size, except where total source regulation limits require a larger size.

Table 23: Maximum Internal Impedance of the Main Power Supply

Main Power Disconnect Panel to PDU	380 VAC	400 VAC	420 VAC	440 VAC	480 VAC
Max Impedance [mΩ]	120	135	150	160	190

The information in the table above assumes that three-phase systems have a symmetrical configuration of the Mains voltage with respect to earth. Where the supply system is not earthed at the source, it is assumed that adequate measures have been provided to detect, limit and remedy any disturbance of symmetry within a reasonably short time. This is in accordance with the IEC 60601-2-44, 201.4.10.2 Supply Mains to ME Equipment and Systems standard.



NOTICE

Power feeders running under the scan room floor, as well as power vault substations under the floor, above the scan suite or in adjacent rooms, may cause excessive EMI fields. The responsibility for meeting all site EMI requirements rests with the customer.

9.3 Ground System

The design of the scanner uses an equal-potential grounding system. All components within the system are provided power on a common ground, so that all the components are suitable for use in the patient environment. Two primary grounding points exist, including:

- A system power ground point located in the PDU.
- A protective earth ground point located on the bottom surface of the gantry stator.

The electrical contractor must ground all patient-accessible metal surfaces to the same potential as the main disconnect panel. The electrical contractor must bond (attach) the ground wire to any intermediate distribution panel the ground wire passes through, in accordance with all local codes.

9.3.1 Equipotential Grounding

The equipotential link is by means of an equipotential bar. This equipotential bar should be connected to the protective earth conductors in the ducts of the non-Arineta cableways and to additional equipotential connections that link all the conducting units in the rooms where Arineta system units are located.

Table 24: Ground Points

Ground Points	Description
Bonding Power from Main Disconnect Panel to PDU	The metal conduit, raceway or armored cabling used to run power from the main disconnect panel to the PDU must be connected to a protective earth ground in accordance with the NEC.
Dedicated Ground	A dedicated 4 (25 mm ²), or larger, insulated copper ground wire must be installed between the main distribution panel and the PDU, in accordance with the NEC.
Grounding Power, Main Disconnect Panel and PDU	All three-phase wires with ground running between the power source, the main disconnect panel and the PDU must be installed in accordance with the NEC.
Maximum Resistance Between PDU and Facility Ground	The resistance between the PDU ground and the facility earth ground must not exceed 0.5 ohm.
Maximum Resistance Between PDU and Earth	The resistance between the PDU ground and earth ground must not exceed 2.0 ohms.

9.4 System Interconnections and Cabling

9.4.1 Power and System Connections

The customer and the electrical contractor should refer to the following system network and power interconnection requirements:

- Interconnect cables are not rated for underground/wet locations.
- Table 25 on page 87 describes the cables from the table to the gantry. Supplied by Arineta.
- Table 26 on page 87 describes the standard-length cable kit (KIT-13725). Supplied by Arineta.
- Table 27 on page 88 describes the long-length cable kit, Optional (KIT-14250). Supplied by Arineta.
- Table 28 on page 89 describes the miscellaneous electrical cables. Supplied by the customer/contractor.

Table 25: Arineta-supplied Cables from the Table to the Gantry

	Run #	Cable Description	PN Standard	Cable Length (m)
Table to Gantry	1	SCB to Table – ECG signal and to PS5	CBL-12152	7.5
	2	SCB to Table – table foot pedals	CBL-12153	2.9
	3	SCB to Table – control to TUB	CBL-12150	6.0
	4	Rotation motor to Table – Ethernet	CBL-12178	4.0
	5	Rotation Motor to Table – up/down motor encoder	CBL-12752	2.0
	6	Rotation Motor to Table – up/down motor sensor	EMA-12755	N/A
	7	Rotation Motor to Table – up/down motor brake and driver	CBL-12751	1.0
	8	Gantry to Table – grounding cable	N/A	N/A

Table 26: Arineta-supplied Cables – Standard Length (Short)

	Run #	Cable Description	PN Standard	Actual Length (m)	Usable Length (m)
PDU	10	Power 230VAC PDU to Console	CBL-12773	10	9.7
	11	Power 230VAC PDU to Stator DC Distributor	CBL-12156	10	8.9
	12	Power 230VAC PDU to Rotor Slip Ring	CBL-12158	10	9.2
	13	Power 230VAC PDU to Table	CBL-12754	10	9.5
	14	Power 230VAC PDU to Rotation CMHV	CBL-12154	10	8.5
	15	Power 800VAC PDU to Brush Block Slip Ring	CBL-11688	10	9.2
	16	Control 24V SCB to PDU	CBL-12165	10	9.3
	17	Power 230AC PDU to Stator	CBL-12185	10	9.2
	18	Grounding PDU to Stator	CBL-13397	10	9.5
Gantry to Console	19	Grounding PDU to Console	CBL-15791	10	9.8
	20	Console SCI to SCB	CBL-14910	10	9.3
	21	Fiber Optic Adapter to Host PC	CBL-12139	10	8.5
	22	Control SCB to Console Recon PC	CBL-12138	20	9.0
	23	Control Ethernet SCB to Console HUB	CBL-12140	10	9.3
	24	Control Front Cover Ethernet SCB Bracket to Console HUB	CBL-13402	10	9.5

Gantry to Console (Continued)	25	Control Rear Cover Ethernet SCB Bracket to Console HUB	CBL-13402	10	9.5
	26	Control Ethernet to CMHv	CBL-12140	10	8.5

Table 27: Arineta-supplied Cables – Long Length (Optional)

	Run #	Cable Description	PN Standard	Actual Length (m)	Usable Length (m)
PDU	10	Power 230VAC PDU to Console	CBL-12774	20	19.7
	11	Power 230VAC PDU to Stator DC Distributor	CBL-12766	20	18.9
	12	Power 230VAC PDU to Rotor Slip Ring	CBL-12767	20	19.2
	13	Power 230VAC PDU to Table	CBL-12769	20	19.5
	14	Power 230VAC PDU to Rotation CMHV	CBL-12768	20	18.5
	15	Power 800VAC PDU to Brush Block Slip Ring	CBL-12770	20	19.2
	16	Control 230AC PDU to SCB	CBL-12771	20	19.3
	17	Power 230AC PDU to Stator PS5	CBL-12186	20	19.2
	18	Grounding PDU to Stator	CBL-13398	20	19.5
	19	Grounding PDU to Console	CBL-15790	20	19.8
Gantry to Console	20	Console SCI to SCB	CBL-14911	20	19.3
	21	Fiber Optic Adapter to Host PC	CBL-12139	20	18.5
	22	Control SCB to Console Recon PC	CBL-13404	20	19.0
	23	Control Ethernet SCB to HUB	CBL-13401	20	19.3
	24	Control Front Cover Ethernet SCB Bracket to Console HUB	CBL-13403	20	19.5
	25	Control Left Cover Ethernet SCB Bracket to Console HUB	CBL-13403	20	19.5
	26	Control Ethernet to CMHv	CBL-13401	20	18.5
	27	Operator Intercom to Stator Cover Bracket	CBL-17224	20	19.5

Table 28: Arineta-supplied Cables – General

Run #	Cable Description	PN Standard	Cable Length (m)
70	USB Extender - Console to SCI Keyboard	*CBL-13412	1.30
71	USB Extender - Console to Operator Mouse	*CBL-13412	1.30
73	Power Cable - Console to the Display Monitor	CBL-12411	4.40
74	DP Console - Host PC to the Display Monitor	CBL-14730	4.40
75	USB Cable - Console Switch to the Display Monitor	CBL-13415	4.40
<p>* These USB cables are connected to devices with additional cable length. If the cable length is still too short, consider adding an additional USB extender, which is not provided with the system.</p>			

Table 29: Arineta-supplied Cables – Console UPS (Optional)

Run #	Cable Description	PN Standard	Cable Length (m)
53	Power PDU to Console UPS - Long	CBL-17125	20
54	Signal Console UPS to PDU	CBL-17119	20
55	Power Console UPS to Console	CBL-17120	5

Table 30: Arineta-supplied Cables – Partial UPS (Optional)

Run #	Cable Description	PN Standard	Cable Length (m)
50	Power Full UPS to PDU	CBL-17122	3
51	Power PDU to Full UPS	CBL-17123	3
52	Signal Full UPS to PDU	CBL-17121	3
	Control Power Off indicator to UPS - Long	CBL-17361	20

Table 31: Arineta Company-supplied Cables – Cable Specification

Run #	UL Cable Information							Pull Size mm (in)
	UL Style	Flam. Rating	Voltage Rating (V)	Temp. Rating (°C)	Diameter mm (in)	# of Conductors	Size AWG	
10	21089	IEC 60332-1-2	300/500	70	7.6 (0.3)	3	N/A	56 (2.2)
11	21089	IEC 60332-1-2	300/500	70	7.6 (0.3)	3	N/A	38 (1.5)
12	20886	IEC 60332-1-2	300/500	70	9.1 (0.36)	3	N/A	9.1 (0.36)
13	21089	IEC 60332-1-2	300/500	70	8.4 (0.33)	4	15	36 (1.42)
14	21089	IEC 60332-1-2	300/500	70	8.4 (0.33)	4	15	45 (1.77)
15	20886	VW-1 (FT-1)	300/500	90	15.3 (0.6)	4	N/A	24 (0.94)
16	2464	FT-4	300	80	8.4 (0.33)	16	22	34 (1.34)
17	2464	FT-4	300	80	7.8 (0.307)	4	18	30 (1.2)
18	1015 (758)	VW-1 (FT-1)	450/750	105	9 (0.354)	16	N/A	9 (0.35)
20	2464	FT-4	300	80	10.8 (0.425)	30	24	55 (2.16)
21	94-V0	IEC60332-1	N/A	80	2 (0.078)	N/A	N/A	11.2 (0.44)
22	2464	FT-4	300	80	7.5 (0.3)	12	24	30 (1.2)
23	1581	VW-1 (FT-1) IEC 60332-1	N/A	70	5.6 (0.22)	8	26	15 (0.59)
24	1581	VW-1 (FT-1) IEC 60332-1	N/A	70	5.6 (0.22)	8	26	15 (0.59)
25	1581	VW-1 (FT-1) IEC 60332-1	N/A	70	5.6 (0.22)	8	26	15 (0.59)

Table 32: Contractor/Customer-supplied Runs

Run	Description	Qty	Size AWG
40	Facility MDP to Room Main Power Disconnect Panel		
	Power	3	
	Ground	1	4 (25)
41	Room Main Power Disconnect Panel to PDU		
	Power	2	
	Ground	1	4 (25)
	NEUTRAL - Not Required	---	
42	Room Main Power Disconnect Panel to System Emergency Off		
	Signal	2	>18
30	PDU to Room Warning X-ray Light(s) Control		
	WARNING LIGHT / AUDIBLE DEVICE 24 V	2	>18
31	PDU to Scan Room Door Interlock		
	Scan Room Door Interlock	2	>18
32	PDU to Room Ready Lights	2	>18
56	Main Power Disconnect to PDU for UPS Partial or Console (Optional)		
	PDU Aux Out 3/4	2	>18

Refer to Table 21 on page 83 for more details about the minimum feeder wire size for AWG (mm²) wire sizes.

9.4.2 Cable Routing Requirements

Install appropriate and properly sized conduits, duct work and floor troughs for all system cables:

- When routing the power wiring, all three-phase wires and ground must run in the same conduit, raceway or duct.
- Route power wires separately from the system control and signal cables using a separate conduit or trough in a raceway or duct.
- You may use a metallic conduit, floor duct or surface raceway for running cables, depending upon local codes and practices.
- Ensure that cable passageways are large enough to install additional cables with all other cables already installed. Do not use non-metallic conduit.
- To minimize the need for additional junction boxes and to eliminate trip hazards, use either a cable raceway system or a raised computer floor for routing all system cabling. The system uses prefabricated cables with large plugs.

9.4.3 Ducting Requirements

Refer to [Illustration 36](#) for the ducting requirements to run all the electrical cabling between the CT system components.

Illustration 37: Ducting Requirements

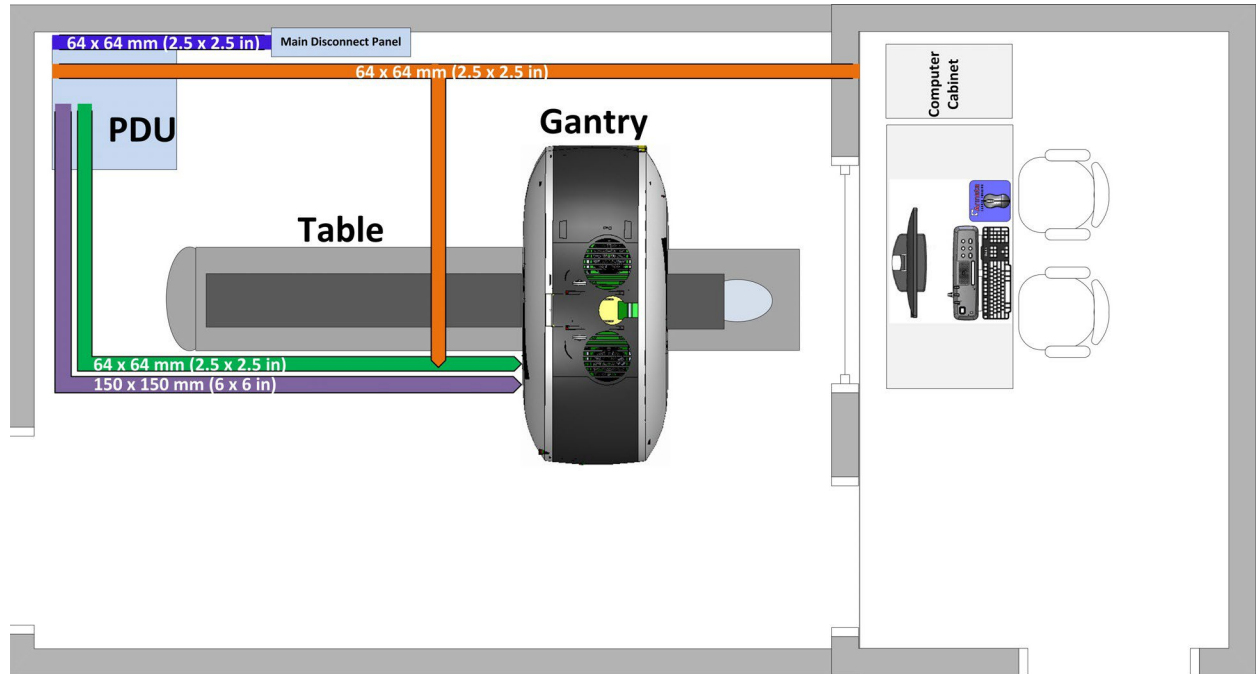

- **Alternate Cable Entry Location Under the Gantry**

If using an alternate cable entry location under the gantry (not recommended), all cables to the gantry must be run in advance of gantry placement.

- **Future Expansion**

Ensure that all cable passageways have additional capacity for future cable installations. It is recommended to run pull lines with all runs.

- **Routing Power Wiring**

All three-phase power wires and the ground line shall run in the same conduit or raceway duct.

- **Power and System Control Wire Separation**

Power supply wires and system control lines shall be located in a separate conduit or ductwork.

- **Cabling External to CT Components**

All customer-supplied equipment and Arineta options with cables outside the covers of the CT system components need to be taken into account for room planning. Ensure that the routing of cables avoids trip hazards and cable damage during system operation.

Table 33: Main Power Disconnect Panel

Maximum Mom. kVA Rating		80 kVA
Required Main Disconnect Catalog No.	300–400 V	NEA090AR/RTC (Includes Auto Restart and Integrated UPS Control)

9.5 Scan Room Warning Light and Door Interlock

The scan room must have a scan warning light and door interlock connected to the scan system, as detailed in the following diagrams.



NOTICE

The X-ray door contact (supplied by the customer) is 24 VDC and 10 mA.

9.6 X-ray Warning Light

9.6.1 Warning Light Configuration and Connection

- The X-Ray On warning light is controlled by signals from the system. This cable should have been run as part of the construction of the scan suite

Table 34: PDU Warning Light Connection Configuration

Connection	X-RAY LAMP	READY LAMP
IN	From 24V power supply	24V Power IN supply
OUT	To X-ray lamp	To System ON lamp



NOTICE

The PDU provides a dry-contact connection for an X-ray lamp that can support up to 230 VAC.

9.7 Scan Room Door Switch Connections

To connect the door interlock:

- This step is site-specific. By default, the PDU is configured to operate **without** an external scan room door interlock switch installed. If the scan room is equipped with an external scan room door interlock switch, the external switch should be connected between the NO (Normally Open) and COM terminal in the back of the PDU. The door switch shall be an NO type (open when door is opened). The switch can handle 24 VDC, 20mA.

This is a dry (No Power) contactor for use by a door interlock

Chapter 10 Environmental Requirements

10.1 Air Quality

See IEC 60654-4 for air-quality guidelines.

10.1.1 Construction Dust Concerns

All construction and cleanup work to the scanner suite must be completed prior to the installation of the CT system. Damage to or early failure of the CT scanner can occur if the scanner is exposed to construction material particles. Ensure that no construction dust occurs in or immediately around the scan suite.

Avoid the following:

- Concrete dust
- Drywall dust
- Ceiling tile dust
- Sawdust or wood shavings
- Dust tracked into the CT suite from adjoining rooms

Failure to take appropriate precautions to protect the system against these types of dust may result in damage to the system and early system failure.

10.1.2 Air-handling System – Initial Startup Considerations

Prior to the initial startup, ensure that the air-handling system ducts and filters are thoroughly clean and free of dust and other potential airborne contaminants. The air-handling ventilation system could blow dust and other airborne contaminants throughout the scan suite, potentially damaging the CT scanner:

- **Thermostats:** The control room and scan room should have separate HVAC thermostats. Thermostats should be within six ft (1,828.8 mm) of the gantry and on opposite sides of doors or wall openings. See Figure 10-1 for reference.

Illustration 38: HVAC Map

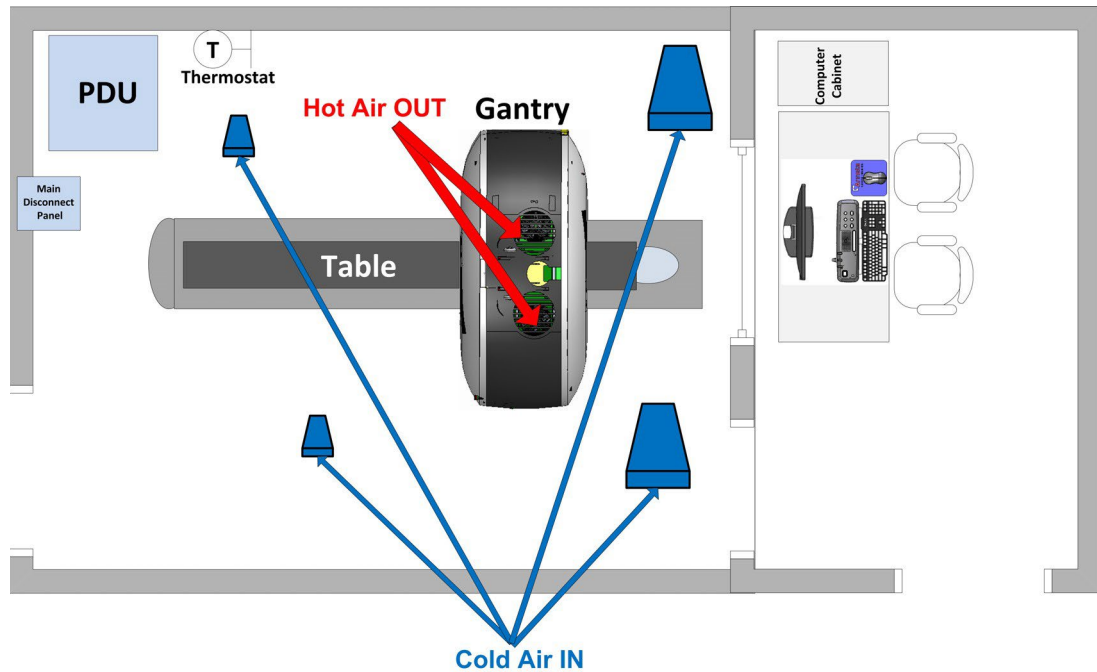

10.1.3 Chemical Contamination Concerns

The silver, copper and gold films used in the CT system are especially sensitive to chemical contamination. The presence of sulfide, chloride and nitrate contaminants (with sulfur being the most damaging) can damage the CT system. If high levels of contaminants exist, consider installing an appropriate air filtration system.

The scanner must not be installed in the same room with a wet film processor. Certain scanner components could become contaminated by the chemicals contained in the processor. Ensure that any sulfide, chloride or nitrate contaminant levels are at acceptable levels (Class 1).

Asbestos contamination of the working environment may be caused by the materials used to cover the concrete floor. The customer is responsible for ensuring that the flooring material does not contain asbestos and if necessary, performing any abatement measures necessary prior to the installation, in order to provide a safe work environment.

10.2 Altitude Operating Range

The system's normal operational altitude range is -150 m to 2,400 m (-492 ft to 7,875 ft), relative to sea level.

The system can be installed at an altitude up to, but not exceeding, 3,000 m (9,843 ft) above sea level. System performance, image quality, reliability and safety cannot be guaranteed at altitudes above 3,000 m.

10.3 Temperature and Humidity

Ensure that the site provides an HVAC system capable of maintaining the temperature and humidity requirements as specified here. The environmental conditions at the site must be maintained at all times (including overnight, weekends and holidays).

Environmental conditions apply to the table, gantry, PDU and console cabinet. Consider patient comfort needs when designing or modifying/designing the HVAC system for the scan suite. Avoid placing any ducts that are blowing air into the exam room that would make the patient uncomfortable. See Figure 10-1 for the recommended HVAC duct location.

To verify that the environmental conditions of the site are met, the temperature and humidity of the installation site must be recorded before and after system installation. Any necessary changes must be made to maintain the proper environmental conditions



NOTICE

Exceeding environmental specifications may adversely affect system operation and image quality.

Table 35: Temperature (Scan and Control Rooms)

System Temperature Limits	Scan Room	Control Room
Maximum allowable ambient room temperature	24°C (75°F)	26°C (79°F)
Recommended ambient room temperature	22°C (72°F)	22°C (72°F)
Minimum allowable ambient room temperature	20°C (68°F)	18°C (64.4°F)
Utility room (optional room where the PDU may be located instead of the scan room)	16–29°C (60–84°F)	16–29°C (60–84°F)



NOTICE

Be certain to account for any cooling equipment cycle-control range, ensuring that the maximum and minimum ambient room temperatures do not exceed those shown in [Table 35 on page 96](#) during room thermal cycling. For example, if the HVAC is capable of $\pm 2^\circ\text{C}$ control, then the limits would be 20°C to 24°C to maintain absolute limits.

Table 36: Humidity (Scan and Control Rooms)

System Humidity Limits	Scan Room	Control Room
Maximum allowable non-condensing relative humidity	60%	70%
Minimum allowable non-condensing relative humidity	30%	30%

10.3.1 System Cooling Requirements

Table 37 below details the heat load produced by the CT system and its various components. Use the BTU/wattage ratings listed to determine the requirements of the HVAC system. Refer to [Illustration 9](#) for air flow details stated below.

- Gantry air intake occurs across the bottom of the gantry.
- Gantry air exhaust occurs across the top of the gantry.

Table 37: System Heat Output

System Component	Maximum BTU/Hr	Maximum Kilowatts
Gantry and Patient Table	20,500	6
PDU (1200 BTU/Hr., 350 W)	1,200	0.352
Console Assembly (includes monitor and Operator Console Cabinet)	5,800	1.7



NOTICE

The heat load of the equipment placed in the scan room must not exceed 30,000 BTU/Hr (8.8 kW). The heat load of the equipment placed in the control room must not exceed 5,800 BTU/Hr (1.7 kW).

Chapter 11 Special Construction Requirements

11.1 Electromagnetic Interference (EMI) Consideration

The system is capable of working in an environment up to the electromagnetic parameters specified below. The customer/owner must ensure that the system is used in such an environment.

Table 38: Electromagnetic Immunity

Immunity Test	EC 60601-1-2 Test Level	Compliance Level	Electromagnetic Environment Guidance
Electrostatic discharge (ESD) IEC 61000-4-2	± 6 kV contact ± 8 kV air	± 6 kV contact ± 8 kV air	Floors should be wood, concrete or ceramic tile. If floors are covered with synthetic material, the relative humidity should be at least 30%.
Electrical fast transient/burst IEC 61000-4-4	± 2 kV for power supply lines ± 1 kV for input/ output lines	± 2 kV for power supply lines ± 1 kV for input/output lines	Mains power quality should be the same as that for a typical commercial or hospital environment.
Surge IEC 61000-4-5	± 1 kV differential mode ± 2 kV common mode	± 1 kV differential mode ± 2 kV common mode	Mains power quality should be the same as that for a typical commercial or hospital environment.
Voltage dips, short interruptions and voltage variations on power supply input lines IEC 61000-4-11	< 5% UT (> 95% dip in UT) for 5 sec.	< 5% UT (> 95% dip in UT) for 5 sec.	Mains power quality should be the same as that for a typical commercial or hospital environment. If the user of the CT system requires continued operation during power mains interruptions, it is recommended that the CT system is powered from an uninterruptible power supply (UPS) or a battery.
Power frequency (50/60 Hz) magnetic field IEC 61000-4-8	3 A/m	3 A/m	Power frequency magnetic fields should be at levels characteristic of a typical location in a typical commercial or hospital environment.

<p>Conducted RF IEC 61000-4-6</p>	<p>3 VRMS 150 kHz to 80 MHz</p>	<p>3 V 150 kHz to 80 MHz</p>	<p>Do not use portable and mobile RF communications equipment closer to any part of the CT system, including cables, than the recommended separation distance calculated from the equation appropriate for the frequency of the transmitter. Recommended Separation Distance: See Table 40 on page 101, where P is equal to the maximum output power rating of the transmitter in watts (W) according to the transmitter manufacturer and d is the recommended separation distance in meters (m). Field strengths from fixed RF transmitters, as determined by an electromagnetic site survey, must meet the following requirements: (a) Should be less than the compliance level in each frequency range and (b) Interference may occur in the vicinity of equipment marked with the following symbol:</p>
<p>Radiated RF IEC 61000-4-3 (Alternate method: Full range IEC 61000-4-21 test in lieu of Large, Permanently- Installed Equipment exemption)</p>	<p>3 V/m 80 MHz to 1 GHz</p>	<p>3 V/m 80 MHz to 1 GHz</p>	
<p>a) Field strengths from fixed transmitters, such as base stations for radio (cellular/cordless) telephones and land mobile radios, amateur radio, AM and FM radio broadcast and TV broadcast cannot be predicted theoretically with accuracy. To assess the electromagnetic environment due to fixed RF transmitters, an electromagnetic site survey should be considered. If the measured field strength in the location in which the CT system is used exceeds the applicable RF compliance level above, the CT system should be observed to verify normal operation. If abnormal performance is observed, additional measures may be necessary, such as reorienting or relocating the CT system.</p>			
<p>b) Over the frequency range 150 kHz to 80 MHz, field strengths should be less than 3 V/m.</p>			

The CT system is intended for use in an electromagnetic environment in which radiated RF disturbances are controlled. The customer or the user of the CT system can help prevent electromagnetic interference by maintaining a minimum distance between portable and mobile RF communications equipment (transmitters) and the CT system as recommended below, according to the maximum output power of the communications equipment.

If you know of or suspect the presence of excessive electromagnetic interference (EMI), consult your PMI for recommendations. Consider the following when attempting to reduce EMI:

- EMI field strength decreases rapidly with distance from the source of the electromagnetic field.
- EMI from a three-phase transformer is much less than a bank of three single-phase transformers of equivalent power.
- Large electric motors are a substantial source of EMI.
- High-powered radio signals are a source of EMI.
- Maintain good shielding of cables and electronic cabinets.
- Consider and measure EMI where the facility power is running near the scan room.
- Pay attention to power substations and high-voltage power lines near the scan facility.
- If you have any concerns, measure for all EMI to confirm that the site meets all required specifications.

Table 39: EMI System Placement

Subsystem	Placement
Gantry	Must be located in an area where the ambient static magnetic field is less than 10E-4 tesla (1,000 milligauss) and the ambient AC magnetic field is less than 10E-6 tesla (10 milligauss); otherwise, EMI affects the image quality of the scanner.
PDU	Must not be placed within 0.3 meters (12 in) of the patient table or gantry. Customer-owned sensitive electronics susceptible to damage by high magnetic fields must not be placed within 1.0 m (39 in) of the PDU.
Console Cabinet/Computer Equipment	Must be located in an area where the ambient static magnetic field is less than 10E-3 tesla (10,000 milligauss).

11.1.1 Electromagnetic Separation Distance

Maintain the electromagnetic separation (between 150 K to 2.5G Hz) distance as described below.

Table 40: Recommended Separation Distances

Rated Maximum Output Power (P) of Transmitter Watts (W)	Separation Distance (Meters) by Frequency of Transmitter 150		
	150 kHz to 80 MHz	150 kHz to 80 MHz	800 MHz to 2.5 GHz
	$d = [3.5/3] \sqrt{P}$	$d = [3.5/3] \sqrt{P}$	$d = [7/3] \sqrt{P}$
0.01	0.12	0.12	0.23
0.1	0.37	0.37	0.74
1	1017	1.17	2.33
10	3.69	3.69	7.38
100	11.7	11.7	23.3

For transmitters rated at a maximum output power not listed above, the separation distance can be estimated using the equation in the corresponding column, where P is the maximum output power rating of the transmitter, in watts (W), according to the transmitter manufacturer.



NOTICE

At 80 MHz and 1 GHz, the separation distance for the higher frequency range applies.



NOTICE

These guidelines may not apply in all situations. Electromagnetic propagation is affected by absorption and reflection from structures, objects and people. As an example, keep a 1W mobile phone (800 MHz to 2.5 GHz carrier frequency) at least 2.3 m from the CT system (in order to avoid image interference risks).

11.1.2 Limitations Management

Adhering to the distance separation recommended (150 KHz to 2.5 GHz) reduces disturbances recorded at the image level, but may not eliminate all disturbances. However, when installed and operated as specified, the system maintains its essential performance by continuing to acquire, display and store diagnostic quality images safely.

11.1.3 Cable Shielding and Grounding

All interconnect cables to peripheral devices must be shielded and properly grounded, except when technologically prohibited. Use of cables not properly shielded and grounded may result in the equipment causing radio frequency interference.

Arineta is not responsible for any interference caused by using other than recommended interconnect cables or panels, or by unauthorized changes or modifications to this equipment.

Unauthorized changes or modifications could void the users' authority to operate the equipment and affect image quality by producing image artifacts.



NOTICE

This equipment complies with the IEC 60601-1-2 Edition 2 and Edition 3 EMC standard for medical devices.



NOTICE

This system complies with the EMC standard when used with supplied cables. If cables of different lengths are required, contact your PMI. Cables cannot be cut, shortened, lengthened or spliced.

The system is suitable for use in an electromagnetic environment, in compliance with the limits and recommendations provided in [Table 41](#) below.

Table 41: Electromagnetic Compliance

Emissions Test	Compliance	Electromagnetic Environment Guidance
RF emissions CISPR 11	Group 1	The CT system uses RF energy only for its internal function. Therefore, its RF emissions are very low and are not likely to cause any interference in nearby electronic equipment.
RF emissions CISPR 11	Class A	When installed in such a shielded location, the CT system is suitable for use in all establishments other than those directly connected to the public low-voltage power supply network that supplies buildings used for domestic purposes.
Harmonic emissions IEC 61000-3-2	N/A	N/A
Voltage fluctuations/ flicker emissions IEC 61000-3-2	N/A	N/A

11.2 Radiation Protection Requirements



NOTICE

Engage a qualified radiological health physicist to review your scan room shielding requirements.

Take into consideration the following during a scan room review:

- Scatter radiation levels within the scanning room (see [Illustration 38](#))
- Equipment placement
- Weekly projected workloads (number of patients/day technique [kvp*ma])
- Materials used for construction of walls, floors, ceiling, doors and windows
- Activities in surrounding scan room areas
- Equipment in surrounding scan room areas (for example, film developer, film storage)
- Room size and equipment placement within the room relative to room size

In case of mounting a Basic Collimator on SpotLight system (250mm coverage of FOV), the results described in the figures below are for a 32cm PMMA phantom in $\mu\text{Gy}/100 \text{ mA}$.



NOTICE

Basic Collimator does not available on SpotLight Duo system

All measurements are for a one-second scan at 140 kV and 400mA 140mm coverage with a 250mm field of view.

Illustration 39: Radiation Protection on the Horizontal Plane at the ISO ($\mu\text{Gy}/100\text{mAs}$)

Z-axis	X-Axis								
	-2	-1.5	-1	-0.5	0	0.5	1	1.5	2
-3.5	3.09	3.35	3.61	3.09	2.32	2.58	2.58	2.58	2.32
-3	3.86	5.92	4.38	4.12	3.35	3.86	4.89	3.86	2.58
-2.5	2.83	5.15	5.41	6.18	5.41	5.92	5.15	4.89	2.58
-2	2.32	4.89	7.73	9.27	9.01	8.76	7.98	5.15	2.32
-1.5	1.03	3.86	12.62	16.48	16.74	16.48	11.07	4.64	1.29
-1	0.26	1.03	4.38	32.96	37.34	33.99	9.27	1.29	0.00
-0.5	0.00	0.00	0.00	ISO			0.00	0.00	0.00
0	0.00	0.00	0.77	ISO			0.77	0.26	0.00
0.5	0.26	1.03	3.86	69.27	114.85	52.53	3.35	1.29	0.52
1	2.58	3.86	15.45	26.27	24.72	26.27	13.39	3.61	2.83
1.5	2.83	5.41	14.16	15.45	11.07	12.36	11.33	6.18	3.09
2	1.80	3.09	6.18	6.95	7.47	9.79	6.44	3.86	2.06
2.5	-	-	-	3.35	4.64	4.89	0.26	-	-

Illustration 40: Radiation Protection on the Vertical Plane at the ISO ($\mu\text{Gy}/100\text{mA}$)

Y-axis	Z-axis											
	-3.5	-3	-2.5	-2	-1.5	-1	-0.5	0	0.5	1	1.5	2
1.5	2.32	2.83	2.83	4.12	2.06	0.52	0.00	0.00	0.00	0.77	4.12	1.03
1	2.83	3.86	5.92	7.47	7.73	1.29	0.00	0.00	0.39	6.18	9.01	6.18
0.5	2.58	3.61	4.89	7.98	12.62	17.51	ISO		14.42	14.42	8.76	5.41
0	2.32	3.35	5.41	9.01	16.74	37.34			114.85	24.72	11.07	7.47
-0.5	0.00	0.00	0.00					22.66	20.86	10.82	6.18	

NOTICE



In the figures above, dark gray boxes indicate areas in which it was not possible to collect data due to the physical scanner body.

NOTICE



In the figures above, light gray boxes indicate the patient table position relative to the scanner body.

NOTICE



0.0 indicates a value less than $0.1\mu\text{Gy}$.

In case of using a SpotLight system with EFOV option (450mm coverage of FOV) or SpotLight Duo system (250/450mm coverage of FOV), the results described in the figures below are for a 32cm PMMA phantom in $\mu\text{Gy}/100\text{mA}$.

All measurements are for a one-second scan at 140 kV and 100mA 140mm coverage with a 450mm field of view.

Illustration 41: Radiation Protection on the Horizontal Plane at the ISO ($\mu\text{Gy}/100\text{mAs}$)

Z-axis	X-axis									
	-2	-1.5	-1	-0.5	0	0.5	1	1.5	2	
-3	3.53	3.79	3.98	3.72	4.49	4.24	4.90	3.79	2.58	
-2.5	4.85	6.88	6.31	6.03	7.11	5.62	5.46	4.93	2.86	
-2	4.54	9.66	10.71	9.39	12.40	9.05	8.48	5.86	3.25	
-1.5	3.53	8.79	14.65	18.15	22.88	16.18	15.67	7.08	2.32	
-1	0.20	3.98	18.50	39.64	52.61	34.87	19.01	3.09	0.15	
-0.5	0.00	0.18	3.08	ISO			0.31	0.19	0.05	
0	0.00	0.30	1.44				0.89	0.40	0.23	
0.5	1.60	2.46	13.54	102.14	128.26	89.51	16.00	2.50	1.39	
1	3.90	5.94	19.91	33.46	35.17	33.06	21.19	6.34	4.60	
1.5	3.77	7.00	12.75	13.33	14.83	16.76	13.14	7.36	5.90	
2	3.30	6.60	7.70	7.92	7.56	7.79	7.65	6.20	3.90	

Illustration 42: Radiation Protection on the Vertical Plane at the ISO ($\mu\text{Gy}/100\text{mA}$)

Y-axis	Z-axis											
	-3.5	-3	-2.5	-2	-1.5	-1	-0.5	0	0.5	1	1.5	2
1.5	3.20	3.90	4.21	7.17	4.82	3.02	0.48	0.65	6.94	5.94	8.73	1.86
1	3.67	5.01	7.78	9.81	15.12	16.18	0.48	1.56	11.39	24.05	14.92	9.88
0.5	3.28	4.59	6.43	10.35	20.41	36.58	ISO		83.59	36.69	16.83	8.13
0	3.11	4.49	7.11	12.40	22.88	52.61			128.26	35.17	14.83	7.56
-0.5	0.00	0.00	0.00						88.58	35.59	14.95	7.61



NOTICE

In the figures above, dark gray boxes indicate areas where it was not possible to collect data due to the physical scanner body.



NOTICE

In the figures above, light gray boxes indicate the patient table position relative to the scanner body.



NOTICE

0.0 indicates a value less than $0.1\mu\text{Gy}$.

11.2.1 Shielding Requirements

The illustrations in this section depict measured radiation levels within the scanning room, while scanning a 32 cm CTDI phantom placed on the patient table, with the technique shown. Use the mAs, kV and aperture scaling factors in Table 42 on page 105 to adjust exposure levels to the scan technique used at the site.



NOTICE

Actual measurements can vary. Expected deviation equals $\pm 15\%$. The maximum deviation anticipated for tube output equals $\pm 40\%$.

Table 42: CT Conditions of Operation

Scan Mode	Axial-Cine
Scan FOV (mm)	250
Detector Coverage (mm)	140
Tube Voltage (kVp)	140
Tube Current (mA)	400
Rotation Time (s)	0.5
Scan Time (s)	1
CTDI Phantom Size (diameter, cm)	32
CTDI Phantom Size (length, cm)	25

NOTICE



This publication uses μGy (micrograys) to measure radiation levels.
The conversion factor from mR to μGy (micrograys) is $1 \text{ mR} = 8.69 \mu\text{Gy}$.

NOTICE



The data in the figures included in this section may change prior to product release.

11.3 Vibration Isolation

The scanning facility must be isolated from vibration, such as hallway foot traffic, nearby rooms with exercise equipment or where exercise occurs, hospital power plants, pumps, motors, air handling equipment, air conditioning units, elevators, parking lots, roads, subways, trains and heliports. Vibration may affect the image quality of the scanner. The degree of isolation must be such that the floor vibration described in [Illustration 42](#) and [Illustration 43](#) is not exceeded.

Illustration 43: Allowable Floor vibration in Acceleration Units Compared to ISO Class A and B Limits

Frequency [Hz]	Acceleration [mm/s^2 , rms]
4	2.5
10	2.5
12.5	3.1
16	5
80	25

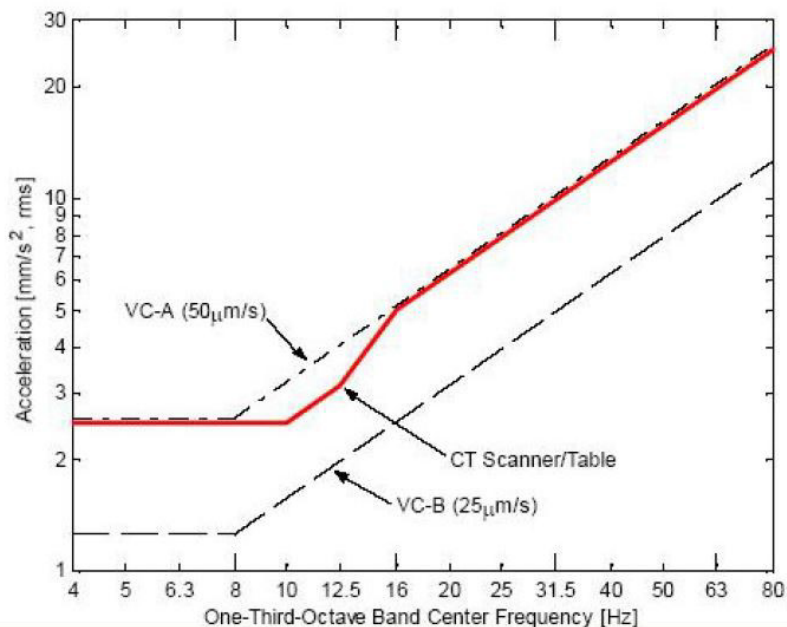
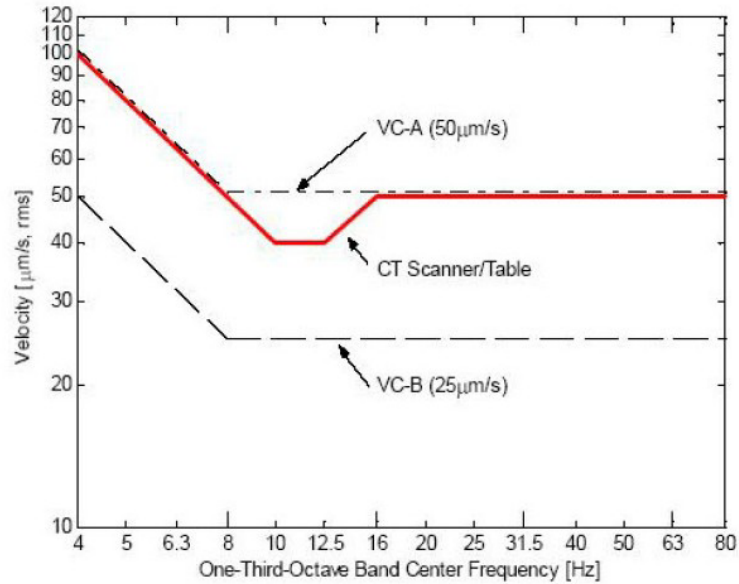

Illustration 44: Allowable Floor Vibration in Velocity Units Compared to IO Class A and B Limits

Frequency [Hz]	Velocity [$\mu\text{m/s}$, rms]
4	100
10	40
12.5	40
16	50
80	50



11.4 Maximum Gantry Audible Sound Level

The maximum sound level produced by the gantry occurs during a CT scan acquisition and is highly dependent upon the acoustic characteristics of the room in which the scanner is installed. The acoustic characteristics of the room include the room area and height, distance of the system from the nearest wall, other walls, floor and ceiling material, size of air ducts, gaps under doors and more.

If the acoustic characteristics of the room are handled properly, the sound level may reach as low as 75 dBA, when measured at a distance of one meter from the nearest gantry surface, in any direction.

11.4.1 Installation Recommendations

- It is highly recommended to consult with an acoustic specialist before installation.
- Sound can slip through gaps in doors, walls, air ducts and other ways. Design and implement the room with acoustic sealing materials in order to improve acoustic sealing.
- Acoustic echo amplifies sound level. Use sound absorbent materials to reduce echo from doors, windows, walls, and ceilings.
- Verify that there are no noise-sensitive parts that can resonate or rattle when exposed to sound.

11.4.2 Acoustic Specifications

The following table specifies the acoustic output of SpotLight equipment.

Table 43: Acoustic Specifications (Under Ambient Conditions)

Room	Arineta Equipment Acoustic Output
Control Room	≤ 62 dBA ¹
Equipment Room	≤ 80 DBA (For SpotLight systems)

NOTE: All Arineta equipment acoustic output values are for base equipment configuration in each room.

1. The customer must use acoustic noise containment solutions to control leakage of acoustic noise from one room to the next.
2. The level indicated for Equipment Room in [Table 43 Acoustic Specifications \(Under Ambient Conditions\)](#) is for Arineta equipment only. The Equipment Room acoustic level must not exceed 85 dBA.

11.4.3 Acoustic Background and Room Design Guidelines

11.4.3.1 Acoustic Background

The acoustic information is provided for site planning and architectural design activities to address acoustics in order to comply with local regulations and customer requirements. For more information about recommended safety procedures regarding patient exposure to CR generated acoustic levels, see the Safety Guide included with the system Operator Manual.

A typical CR suite has two types of acoustic noise issues:

- Acoustics within the rooms in which the patients and technicians are impacted by the noise of the CR System as the system scans.
- Noise transmitted to other spaces through airborne and structure-borne paths. Refer to the system Preinstallation Manual for details on structure-borne acoustic management.

11.4.3.2 Airborne Acoustic Background

The airborne transmission path entails the excitation of air which generates acoustic noise similar to an intense loudspeaker. The airborne noise passes through walls through any openings (for example, small holes, cracks, HVAC ducts, and waveguides) into surrounding spaces within, and possibly beyond, the confinements of the building. Acoustic energy can transmit across distances of significant length.

Examples of airborne acoustics issues may include the following (and is not limited to these only):

- Operator exposure at Operator Workstation (For example, Operator viewing in-line with the patient inside the CT may require a higher acoustic attenuation window.)
- Image reading rooms adjacent to CT Room (may be separated by hallways)
- Secretarial, offices, meeting rooms, patient rooms (ICU, exam, primary care, and so on)
- Adjacent residential areas or spaces

- In-house library facilities

11.4.3.3 Structure-borne Acoustic Background

The structure-borne transmission path is the result of mechanical excitation of the floor or building structure causing the building to vibrate. The vibration of the surfaces at surrounding spaces then radiates as acoustic noise. Acoustic energy can transmit across distances of significant length.

NOTE: Less than 5% of installed base sites have experienced structure-borne acoustic issues.

Examples of structure-borne acoustic issues may include the following (and is not limited to these only):

- Areas directly above or below the CT Room (may not always be an issue)
- Image reading rooms adjacent to CT Room (may be separated by hallways)
- Secretarial, offices, meeting rooms, patient rooms (ICU, exam, primary care, and so on)
- Adjacent residential areas or spaces
- In-house library facilities

11.4.3.4 Acoustic Design Guidelines for the CT Room

Noise generated by the CT System is inherent to the operation of the system. The sound quality (human perception) within the CT Room can be modified by including sound absorbing materials to make the room sound more subdued and less harsh by absorbing sound energy at some frequencies, while not impacting the overall sound level.

- Use ceiling tiles with fiberglass panels having a 51 mm (2 in.) thickness set into the standard T-bar grid system.
- Adding fiberglass panels to the side walls covering approximately 20% of the side wall surface area. The panels should focus on covering the top half of the side walls. Panels could take many different and decorative shapes to improve the sterile look of the rooms. Typically, panels might be on the order of 1.2 m x 1.8 m (4 ft. x 6 ft.) with a thickness of 102 mm (4 in.) or equivalent. Panel shape could vary to produce mosaic effects to meet the customer preference. Any decorative materials used to cover the wall panels must be porous so that sound waves can pass through with ease. In principle, a person should be able to breathe through the material with ease. Fire retardant cloth should be used. The NRC (Noise Reduction Coefficient) of the panels should be 0.95 or better when mounted against a hard surface such as drywall or concrete.

11.4.3.5 Acoustic Design Guidelines for Inter-spacial Areas

Acoustic noise control to mitigate noise from being transmitted to other spaces often amounts to paying attention to small details while working with ordinary construction materials. The key objectives are to eliminate all cracks and gaps in the wall construction while making sure that the doors, walls, floor, and ceiling have adequate transmission loss through mass or special double wall construction, along with good fitting massive doors.

The entire CT must be surrounded by walls with substantial mass and/or double wall construction so that noise is contained in the room and not allowed to pass through into nearby spaces. Wall junctions must be sealed with acoustical sealant so that noise waves do not escape from the room. In principle, if the room were filled with smoke and under a positive pressure, no smoke would leak from the room.

11.4.3.6 Wall Construction

Wall Construction will entail ordinary building materials in a careful configuration.

- The preferred wall construction should have a Weighted Sound Reduction Index (Rw) rating of 46 or an ASTM Sound Transmission Coefficient (STC) of 50. This entails the use of standard wall construction of steel studs (typically 92 mm (3-5/8 in.)) with 2 layers of Type X drywall (typically 16 mm (5/8 in.)) on each side (a total of 4 layers) and fiberglass batt in the stud cavity. All drywall must be overlapped by 152 mm (6 in.) or more. Beads of (USG) acoustical caulking (non-hardening) would be used around the entire perimeter of the drywall. Any form of wall penetration should be avoided. Any necessary wall penetrations must be sealed using combination of acoustical caulking (nonhardening) and fiberglass batt material.
- The top of the wall must join the ceiling or floor above so that no cracks or gaps occur. If metal pan is used on the ceiling or floor (above), then flute seals would be used to seal the gaps between the drywall and the pan. Alternately, drywall can be cut out to fit into the flutes. Acoustical caulking (non-hardening) will be used to seal the remaining cracks and gaps.

11.5 Other Construction Considerations

The following other construction considerations apply:

- **Patient Viewing Window Dimensions**

The recommended patient viewing window dimensions are 1,219 mm Wide x 1,067 mm High (48 in X 42 in). However, other dimensions may be used.

- **Support Structure Installation**

Approved steelwork or an equivalent support structure for mounting equipment to walls, ceilings and floors must be installed prior to system installation.

- **Finished Walls**

The scan and control room walls must be painted prior to system installation. **Exception:** A primer coat of paint is acceptable for system installation. After the system is installed, any final coats of paint require the system to be completely powered down and completely covered until the painted surfaces are dry. Spray painting is not permitted, as it can seriously damage Arineta CT system components.

- **System Options Construction Requirements**

Confirm that all options have been reviewed and final locations determined. The customer is responsible for installation of all power source connections and all control cables for all options prior to system delivery. Options purchased and installed during initial installation and options installed after installation may require power or data connections. For more details, see Customer Responsibility [on page 19](#).

All non-Arineta-installed options should be reviewed, and final locations determined prior to system delivery. The customer is responsible for preinstalling all ceiling mounting plates/pedestals before system installation begins.

Chapter 12 Communications Requirements

12.1 Network Cable Routing

The CT system connects to the facility's network through the console. To enable proper network cabling, the customer and the customer's IT contact should:

- Provide an active RJ45 network wall outlet within a minimum of 2,743.0 mm (9.0 ft) of the console cabinet.
- Use a Broadband interface type: 100-Mb-to-1-Gb-Ethernet connection.
- Ensure a network broadband line is installed and active.
- Provide a patch cable, not to exceed 3,000.0 mm (10.0 ft) to connect the console cabinet to a wall outlet. This includes a minimum of 305.0 mm (12.0 in) of slack to allow movement of the cabinet.
- Complete any cable duct work or conduit installation required for routing network cables to the workstation, camera and console cabinet.
- Ensure the communication run from the hospital/facility network switch to the RJ45 wall outlet does not exceed 88 m (290 ft).

12.2 Broadband Connectivity Information

The customer is responsible for providing the dedicated network IP address for the CT scanner.

The nearest Arineta zone broadband specialists typically become involved to ensure that the needs for the broadband connection and connectivity have been met. Not all areas of the globe have a zone broadband specialist. Typically, these individuals are trained to ensure that all required information is provided by the customer in support of the installation. If the zone does not have a broadband specialist, then the PMI should work with the customer to gather the required information in support of the installation.

The CT scanner is typically installed in a medical facility. The facility may or may not have dedicated in-house network IT support personnel for the facility. If there are dedicated in-house network IT personnel, the customer and PMI should work with the Arineta zone broadband specialist (if one exists) or the Arineta field engineers to acquire the required broadband information to support the installation.

For smaller facilities and clinics that may not have dedicated in-house network IT personnel, the PMI should work with the zone broadband specialist (if one exists) in advance to obtain the required broadband information and ensure that the needs of the broadband connection and connectivity have been met prior to the installation:

- **IT Infrastructure Changes:** Zone broadband specialist and PMI will work with customer to complete identified infrastructure changes.
- **VPN-compatible Appliance:** Zone broadband specialist shall provide a VPN-compatible appliance to support the IPsec tunneling protocol and 3DES data encryption.

- **Coordinate VPN Activities:** The site IT contact shall coordinate VPN activities between the radiology/cardiology department and the IT department.
- **Internet Service Provider:** Customer and/or zone broadband specialist or dedicated.
- **Firewall access:** Customer and/or zone broadband specialist or dedicated in-house network personnel responsible for ensuring the firewall allows outbound push access via PORT 443 (standard secured HTTPS port) to support the system connection to remote service and option of PPU (Pay Per Use), see 12.2.1 setting configuration.
- **Antivirus protection:** Build-in Windows Defender antispysware program is a part of the device and is designed to prevent and detect unwanted spyware program installations. Device firewall rules prevent all Inbound connections except for essential services: ICMP (ping); SNMP (network management). Custom Antivirus agent installation is not supported: it has impact on the device performance and even functionality; it opens the inbound ports for updates and raises the penetration risk.
- **Customer, Site and System Contact information:** Customer shall provide the Arineta PMI with an accurate site address, contact name, contact phone number and contact email address for the customer's IT person or network support personnel.
- **Ensuring Broadband Infrastructure Requirements:** Site IT contact works as the liaison to ensure that the site's broadband connectivity meets Arineta requirements, as determined by mutual assessment with the Arineta connectivity team.
- **Equipment Assessment:** Site IT contact must complete an equipment assessment with the Arineta connectivity team in order to determine site broadband readiness.

12.2.1 PPU (Pay Per Use) option Network Setting

1. Open Outbound communication
2. Add DNS record to site internal DNS with multiple IPs
 - Record Name: **us.harbor-arineta.com**
 - IP Address: **3.33.218.54**
 - IP Address: **15.197.247.204**

Note: Add both IP's addresses

3. Firewall requirement: open in Site Firewall (not in the system Firewall) **TCP Port 443** outbound connection for domain name **us.harbor-arineta.com**
4. If the site uses **proxy** for outbound connections, the following steps should be performed:
 - By the local IT representor- allow communication and exempt from authentication the following URLs:
 - **us.harbor-arineta.com**
 - **license-portal.harbor-arineta.com**

© 2023 Arineta Ltd. All Rights Reserved.

Arineta Ltd.

15 Halamish St.

Caesarea 3088900 Israel

www.arineta.com

