



SpotLight™

SpotLight Duo™

DICOM Conformance Statement DireCT

MAN-19520EN

Product version: 1.3.1

Aug-2024

1 Table of Contents

2 Overview.....	4
2.1 Content and Transfer	5
2.1.1 Structured Reporting Root Template IDs	5
2.2 DIMSE Services	6
2.2.1 Verification	6
2.2.2 Storage	6
2.2.3 Workflow Management	6
2.2.4 Query/Retrieve (N/A)	6
2.2.5 Printing (N/A)	6
2.3 DICOM Web Services (N/A)	6
2.4 Media Services	6
2.5 Real Time Video Service (N/A)	6
2.6 De-identification Profiles	7
2.7 Specific Character Sets	7
3 Introduction	8
3.1 Revision History	8
3.2 Audience	8
3.3 Remarks	8
3.4 Terms and Definitions.....	9
3.5 Abbreviations	12
3.6 References	13
3.7 Product manufacturer.....	14
4 Implementation Model	15
4.1 Application Entities and Data Flow	15
4.1.1 Functional Definition of Scanner Application Entity	16
4.1.2 Implementation Identifying Information.....	16
4.1.3 Number of Associations	16
4.1.4 Asynchronous Nature	16
4.2 Activity Verify DICOM Connection	16
4.2.1 SOP Classes	16
4.2.2 Association Initiation Policy	16
5 Service and Interoperability Description	17

5.1 Mapping of Services to Application Entities	17
5.2 Supported DIMSE Services	17
5.2.1 Basic Worklist Management Service	17
5.2.1 SCP of the Modality Worklist Information Model - FIND SOP Class (N/A)	19
5.2.2 Modality Performed Procedure Step Service (N/A)	19
5.2.3 Unified Worklist and Procedure Step Service (N/A)	19
5.2.4 Instance Availability Notification Service (N/A)	19
5.2.5 Storage Service	19
5.2.5.1 SCU of the Storage SOP Classes	19
5.2.5.2 SCP of the Storage SOP Classes (N/A)	20
5.2.6 Storage Commitment Service (N/A)	20
5.2.7 Query/Retrieve Service Class	20
5.2.8 Print Management Service (N/A)	23
5.3 Supported DICOM Web Services (N/A)	23
5.4 Media Service	23
5.5 Real Time Video Service (N/A)	23
5.6 Cross Service Considerations (N/A)	23
5.7 Specific Character Sets (N/A)	23
6 Configuration	24
6.1 General Configuration Parameters	24
6.2 Configuration of DIMSE Services	25
6.2.1 Basic Worklist Management Service Configuration (N/A)	27
6.2.2 Modality Performed Procedure Step Service Configuration (N/A)	27
6.2.3 Unified Worklist and Procedure Step Service Configuration (N/A)	27
6.2.4 Instance Availability Notification Service Configuration (N/A)	27
6.2.5 Storage Service Configuration (N/A)	27
6.2.6 Storage Commitment Service Configuration (N/A)	27
6.2.7 Query/Retrieve Service Configuration (N/A)	27
6.2.8 Print Management Service Configuration (N/A)	27
6.3 Configuration of DICOM Web Services (N/A)	27
6.3.1 URI Web Service Configuration (N/A)	27
6.3.2 Studies Web Service Configuration (N/A)	27
6.3.3 Worklist Web Service Configuration (N/A)	27

6.3.4 Non-Patient Instances (NPI) Web Service Configuration (N/A)	27
6.4 Configuration of Media Storage Service (N/A)	27
6.5 Configuration of Real Time Video Service (N/A)	27
6.6 Configuration of Audit Trail – Syslog (N/A)	27
7 Network and Media Communication Details	27
7.1 General	27
7.1.1 General Association Parameters	28
7.2 Specifications	29
7.2.1 <AE1> Application Entity	29
7.3 Status Codes	34
7.3.1 General AE Communication and Failure Behavior and Handling	34
7.3.2 DIMSE Services	35
7.3.3 DICOM Web Services N/A	37
8 Security	46
8.1 Introduction	46
8.2 External Network Requirements	46
8.3 TCP Port Configuration	50
8.4 DICOM Security Profiles Support	50
8.4.1 Secure Use and User Identity Profiles	50
8.4.2 Secure Transport Connection Profiles	50
8.4.3 Media Storage Security Profiles	50
8.4.4 Attribute Confidentiality Profiles	51
8.4.5 Digital Signature Profiles (N/A)	52
8.4.6 Additional DICOM Security Profiles (N/A)	52
8.5 User Identity Negotiation Support (N/A)	52
8.6 Web Services Security Features (N/A)	52
8.7 Other Security Features (N/A)	52
9 Annexes	52
Annex A. Information Object Definitions (IODs)	52

2 Overview

This version of the DICOM Conformance Statement applies to CT scanners manufactured by Arineta.

The scanner uses X-rays to create detailed cross-sectional images of the body: CT images. The images are usually transferred from the scanner to storage, workstations and other imaging-related software for reading, processing, and clinical diagnostics. The scanner integrates with hospital or clinic workflow systems, such as Hospital/Radiology Information Systems, to ensure efficient management, storage, and retrieval of patient imaging data as well as structured reports and screen captures.

The scanner allows setting up of several storage destinations, automatic send to storage upon acquisition of the images as well as manual send. Images can be de-identified to protect patient privacy. The scanner supports splitting of exams along with editing of patient details to update patient information and resend the study to storage.

The Scanner provides the following DICOM features:

- Send DICOM Images to DICOM storage devices (e.g., Workstation or PACS)
- Query a worklist provider (e.g., HIS/RIS)
- Export DICOM Images to USB media

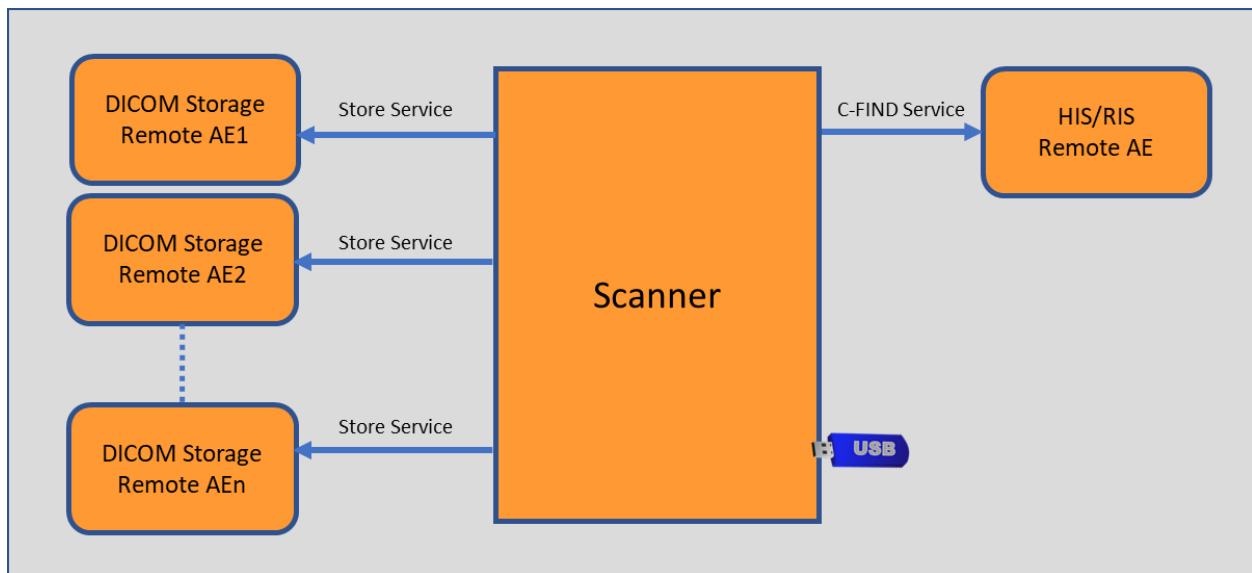

Figure 2-1. Overview of Implemented Services

2.1 Content and Transfer

Table 2-1. Storage SOP Classes

SOP Classes		Transfer Syntax Set	DIMSE Services		DICOM Web Services		Media Services			Function			
			SCU	SCP	UA	OS	FSC	FSU	FSR	Create	Display	Process	Archive
CT image storage	1.2.840.10008.5.1.4.1.1.2	U	Y	N	N	N	Y	Y	N	S	N	N	N
Xray radiation dose SR report	1.2.840.10008.5.1.4.1.1.7	U	Y	N	N	N	Y	Y	N	S	N	N	N
Secondary capture	1.2.840.10008.5.1.4.1.1.88.67	U	Y	N	N	N	Y	Y	N	S	N	N	N

Table 2-2. Supported Transfer Syntaxes

Transfer Syntax Set	Transfer Syntax Name	Transfer Syntax UID	DICOM Web Service Bulkdata Media Type
Uncompressed Transfer Syntax Set (U)	Implicit VR Little Endian	1.2.840.10008.1.2	N/A
	Explicit VR Little Endian	1.2.840.10008.1.2.1	N/A

2.1.1 Structured Reporting Root Template IDs

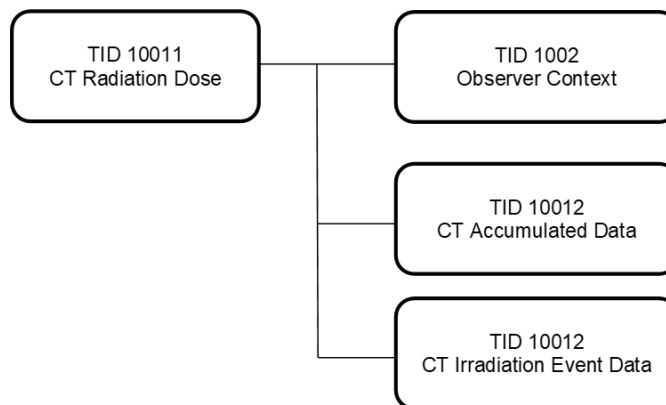

Figure 2-2. Structured Reporting Root Template IDs

Table 2-3. Supported Root SR Template IDs (TIDs)

Name	Root TID	Function	SOP Classes	Condition
CT Radiation Dose	10011	CREATE;	X-Ray Radiation Dose SR Storage 1.2.840.10008.5.1.4.1.1.88.67	
Observer Context	1002	CREATE:	1.2.840.10008.5.1.4.1.1.88.33	
CT Accumulated Dose Data	10012	CREATE:		
CT Irradiation Event Data	10013	CREATE;		

2.2 DIMSE Services

2.2.1 Verification

Table 2-4. Verification SOP Class

SOP Classes		Transfer Syntax		SCU	SCP
Verification	1.2.840.10008.1.1	Implicit VR Little Endian	1.2.840.10008.1.2	Y	N
		Explicit VR Little Endian	1.2.840.10008.1.2.1	Y	N

2.2.2 Storage

2.2.3 Workflow Management

Table 2-5. Workflow Management SOP Classes

SOP Classes		Transfer Syntax		SCU	SCP
Modality Worklist Information Model - FIND	1.2.840.10008.5.1.4.31	Implicit VR Little Endian	1.2.840.10008.1.2	Y	N
		Explicit VR Little Endian	1.2.840.10008.1.2.1	Y	N

2.2.4 Query/Retrieve (N/A)

2.2.5 Printing (N/A)

2.3 DICOM Web Services (N/A)

2.4 Media Services

The scanner does not support Media application services. It supports export of DICOM images to USB media.

2.5 Real Time Video Service (N/A)

2.6 De-identification Profiles

Table 2-14. De-Identification Profiles

Profile	Option
Basic Application-Level Confidentiality Profile	Clean Pixel Data Option

2.7 Specific Character Sets

Table 2-15. Supported Specific Character Sets

Defined Term	IANA	Description
Single-Byte Character Sets without Code Extensions		
ISO_IR 6	ISO-646	Default Repertoire
ISO_IR 100	ISO-8859-1	Latin Alphabet No.1 (West Europe) English, French, Spanish, German
ISO IR-101	ISO-8859-2	Latin Alphabet No. 2 (East Europe) Hungarian
Single-Byte Character Sets with Code Extension		
Multi-Byte Character Sets without Code Extensions		
GB18030	GB18030	GB18030-2000 (P.R China Norm GB18030) English, Simplified Chinese
Multi-Byte Character Sets with Code Extensions		

3 Introduction

3.1 Revision History

Revision	Date	Product Version	Change
1.00	March 2016		Initial release
1.10	24-July-2016	V1.0	Add product manufacturer chapter 4
1.20	24-October-2016		1. Add: Transcoding of Transfer Syntaxes <ol style="list-style-type: none"> 1. WorkList DICOM service 2. Verification DICOM service 3. DICOM Tags 2. Change both old Arineta's and GE private DICOM tags. Change conformance statement overview
1.30	10-July-2017		1. Product name update from SpotLight to CardioGraphe 2. Update manufacturer address
1.40	15-October-2017		1. Support Chinese character set 2. Change both old Arineta's and GE private DICOM tags. 3. Update De-identification (Anonymization)
1.41	10-Jan-2018		Update manufacturer address
1.42	21-Apr-2020	V1.2	Updates for SW V1.2 Added attributes to Contrast/Bolus Module Added Arineta private tags
1.43	22-Nov-2020	V1.2.1	Updates for SW V1.2.1
1.44	25-Jan-2021		Added support for character set Latin 2 (ISO-IR-101)
2.00	16-Aug-2023	V1.3	Updated for SW V1.3 Document template changed to comply with finalized DICOM standard

3.2 Audience

This document is written for the people that need to understand how the Scanner will integrate into their healthcare facility. This includes both those responsible for overall imaging network policy and architecture, as well as integrators who need to have a detailed understanding of the DICOM features of the product. This document contains some basic DICOM definitions so that any reader may understand how this product implements DICOM features. However, integrators are expected to fully understand the DICOM terminology, how the tables in this document relate to the product's functionality, and how that functionality integrates with other devices that support compatible DICOM features.

3.3 Remarks

The DICOM Conformance Statement is contained in chapter 4 through 8 and follows the contents and structuring requirements of DICOM PS 3.2.

This DICOM Conformance Statement by itself does not guarantee successful interoperability of Arineta equipment with other vendor equipment.

3.4 Terms and Definitions

The following list includes DICOM Terms, that are used throughout this Conformance Statement:

Term	Definition
Abstract Syntax	The information agreed to be exchanged between applications, generally equivalent to a Service/Object Pair (SOP) Class. Examples: Verification SOP Class, Modality Worklist Information Model Find SOP Class, Computed Radiography Image Storage SOP Class.
Application Entity (AE)	A representation of the external behavior of an application process in terms of DICOM Network Services, Web Services and/or media exchange capabilities implemented in one or more roles. A single device may have multiple Application Entities.
Application Entity Title (AET)	The externally known name of an Application Entity, used to identify a DICOM application to other DICOM applications on the network.
Application Context	The specification of the type of communication used between Application Entities. Example: DICOM network protocol.
Association	A network communication channel set up between Application Entities.
Attribute	A unit of information in an Information Object Definition; a Data Element identified by a tag. The information may be a complex data structure (Sequence), itself composed of lower-level data elements. Examples: Patient ID (0010,0020), Accession Number (0008,0050), Photometric Interpretation (0028,0004), Procedure Code Sequence (0008,1032).
Data Element	A unit of information as defined by a single entry in the data dictionary. An encoded Information Object Definition (IOD) Attribute that is composed of, at a minimum, three fields: a Data Element Tag, a Value Length, and a Value Field. For some specific Transfer Syntaxes, a Data Element also contains a VR Field where the Value Representation of that Data Element is specified explicitly
Information Object Definition (IOD)	The specified set of Attributes that comprise a type of data object; does not represent a specific instance of the data object, but rather a class of similar data objects that have the same properties. Examples: MR Image IOD, CT Image IOD, Print Job IOD. The Attributes within an IOD may be specified as Mandatory (Type 1), Required but possibly unknown (Type 2), or Optional (Type 3), and there may be conditions associated with the use of an Attribute (Types 1C and 2C).
Media Application Profile	The specification of DICOM information objects and encoding exchanged on removable media (e.g., CDs).

Module	A set of Attributes within an Information Object Definition that are logically related to each other. Example: Patient Module includes Patient's Name, Patient ID, Patient' Birth Date, and Patient's Sex.
Negotiation	First phase of Association establishment that allows Application Entities to agree on the types of data to be exchanged and how that data will be encoded.
Origin Server	Refers to the program that can originate authoritative responses to HTTP requests for a given Target Resource. The term "server" refers to any implementation that receives a web service request message from a user agent.
Presentation Context	The set of DICOM Network Services used over an Association, as negotiated between Application Entities; includes Abstract Syntaxes and Transfer Syntaxes.
Private SOP Class	A SOP Class that is not defined in the DICOM Standard but is published in an implementation's Conformance Statement.
Protocol Data Unit (PDU)	A packet (piece) of a DICOM message sent across the network. Devices must specify the maximum size packet they can receive for DICOM messages.
Security Profile	A set of mechanisms, such as encryption, user authentication, or digital signatures, used by an Application Entity to ensure confidentiality, integrity, and/or availability of exchanged DICOM data.
Service Class Provider (SCP)	Role of an Application Entity that provides a DICOM network service; typically, a server that performs operations requested by another Application Entity (Service Class User). Examples: Picture Archiving and Communication System (image storage SCP, and image query/retrieve SCP), Radiology Information System (modality worklist SCP).
Service Class User (SCU)	Role of an Application Entity that uses a DICOM Network Service; typically, a client. Examples: imaging modality (image storage SCU, and modality worklist SCU), imaging workstation (image query/retrieve SCU).
Service/Object Pair Class (SOP Class)	The specification of the network or media transfer (service) of a particular type of data (object) ; the fundamental unit of a DICOM interoperability specification. Examples: Ultrasound Image Storage Service, Basic Grayscale Print Management.
Service/Object Pair Instance (SOP Instance)	An information object; a specific occurrence of information exchanged in a SOP Class. E.g., a specific X-ray image.
Specialized SOP Class	A SOP Class that is derived from the Standard that is specialized by additional type 1, 1C, 2, 2C, or 3 Attributes, by enumeration of specific permitted Values for Attributes, or by enumeration of specific permitted Templates. The additional Attributes may either be drawn from the Data Dictionary in PS3.6 or may be Private Attributes.
Standard SOP Class	A SOP Class defined in the Standard, and that is implemented and used without any modifications.

Standard Extended SOP Class	A SOP Class that is defined in the standard, and that is extended by additional type 3 Attributes. The additional Attributes may either be drawn from the DICOM Data Dictionary in PS3.6 or may be Private Attributes.
Tag	A 32-bit identifier for a Data Element, represented as a pair of four-digit hexadecimal numbers, the "group" and the "element". If the "group" number is odd, the tag is for a private (manufacturer-specific) data element. Examples: (0010,0020) [Patient ID], (07FE,0010) [Pixel Data], (0019,0210) [private data element].
Transfer Syntax	The encoding used for exchange of DICOM information objects and messages. Examples: JPEG compressed (images), Little Endian Explicit Value Representation.
TLS-Secured Port	TCP port on which an implementation accepts TLS connections to exchange DICOM information.
Unique Identifier (UID)	A globally unique "dotted decimal" string that identifies a specific object or a class of objects; an ISO-8824 Object Identifier. Examples: Study Instance UID, SOP Class UID, SOP Instance UID.
User Agent	A client in a network protocol used in communications within a client-server distributed computing system. In particular, the Hypertext Transfer Protocol (HTTP) identifies the client software originating the request, using a user-agent header, even when the client is not operated by a user.
Value Representation (VR)	The format type of an individual DICOM data element, such as text, an integer, a person's name, or a code. DICOM information objects can be transmitted with either explicit identification of the type of each data element (Explicit VR), or without explicit identification (Implicit VR) ; with Implicit VR, the receiving application must use a DICOM data dictionary to look up the format of each data element.

3.5 Abbreviations

	Acronym	Definition
AE	Application Entity Application	
AET	Entity Title Computer Aided	
CAD	Detection	
CDA	Clinical Document Architecture Context	
CID	Identifier	
CT	Computed Tomography	
DCS	DICOM Conformance Statement	
DHCP	Dynamic Host Configuration Protocol	
DICOM	Digital Imaging and Communications in Medicine	
DVD	Digital Versatile Disk	
ELE	Explicit VR Little Endian	
FSC	File-Set Creator	
FSE	Field Service Engineer	
FSU	File-Set Updater	
FSR	File-Set Reader	
IANA	Internet Assigned Numbers Authority	
IHE	Integrating the Healthcare Enterprise	
ILE	Implicit VR Little Endian	
IOD	Information Object Definition	
IPv4	Internet Protocol version 4	
IPv6	Internet Protocol version 6	
ISO	International Organization for Standardization	
MPPS	Modality Performed Procedure Step	
MWL	Modality Worklist	
NEMA	National Electrical Manufacturers Association	
NTP	Network Time Protocol	
O	Optional (Key Attribute)	
OID	Object Identifier	
OP	Ophthalmic Photography	
OS	Origin Server	
OSI	Open Systems Interconnection	
PACS	Picture Archiving and Communication System	



PDU	Protocol Data Unit
PHI	Protected Health Information
PPS	Performed Procedure Step
QIDO-RS	Query based on ID for DICOM Objects by RESTful Services
RTV	Real Time Video
SCP	Service Class Provider
SCU	Service Class User
SDP	Service Description Protocol
SOP	Service-Object Pair
SPS	Scheduled Procedure Step
SR	Structured Reporting
STOW-RS	STore Over the Web by RESTful Services
TCP/IP	Transmission Control Protocol/Internet Protocol
TID	Template Identifier
UA	User Agent
UI	User Interface
UID	Unique Identifier
UL	Upper Layer
UPS	Unified Procedure Step
UPS-RS	Unified Procedure Step by RESTful Services
VR	Value Representation
WADO-RS	Web Access to DICOM Objects by RESTful Services
WADO-URI	Web Access to DICOM Objects by URI

3.6 References

NEMA PS3 Digital Imaging and Communications in Medicine (DICOM) Standard, available free at <http://medical.nema.org/>

3.7 Product manufacturer

Table 0-1: Product Manufacturer

Model Name	Manufacturer	European Authorized Representative
SpotLight	 Arineta Ltd., 15 Halamish Street Caesarea 3088900 Israel Tel: +972 4 6374000 Fax: +972 4 6277006 office@arineta.com	N/A
SpotLight Duo	 Arineta Ltd., 15 Halamish Street Caesarea 3088900 Israel Tel: +972 4 6374000 Fax: +972 4 6277006 office@arineta.com	N/A

4 Implementation Model

The clinical scanner application is the main driver of the DICOM functionality. It provides the user interface to configure the DICOM interoperability parameters, user preferences and application entities as well as verification of the connections.

The clinical operator creates the DICOM storage components and transmits them to the configured Application entities. The storage components include the CT image, Secondary capture and the Structured Dose report.

The DICOM dictionary, anonymization, transfer and query are implemented by a 3rd party component: Fellow Oak DICOM, Version 3.0.0.

Note that all DICOM communication is initiated only by the scanner and thus only SCU roles are implemented.

The DICOM transfer is managed sequentially by the DICOM jobs sever and each transfer communication and status are logged.

FSEs using the scanner are limited to export only anonymized DICOM data sets.

The DICOM storage classes can be exported to an USB media.

The scanner uses several character sets (pending configuration) and supports Latin-1, Latin-2 and Simplified Chinese.

4.1 Application Entities and Data Flow

The network and media interchange application model for the Scanner is shown in below.

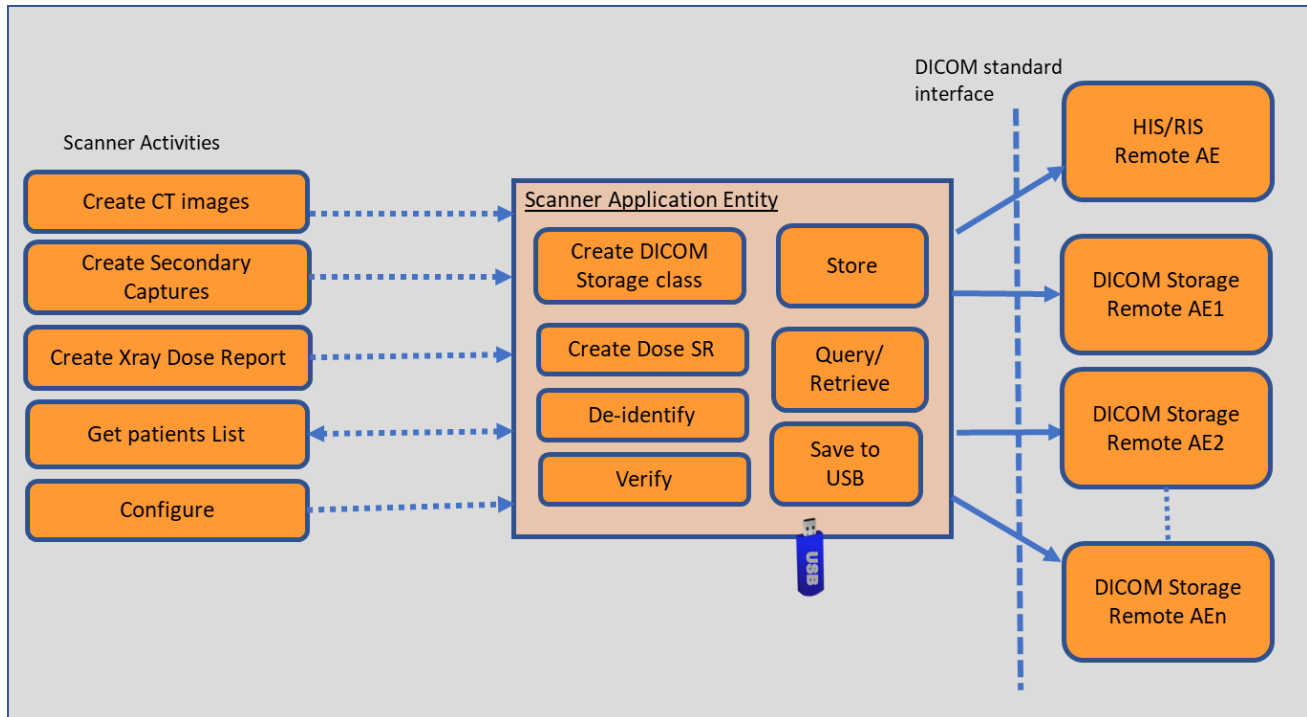

Figure 4-1. Scanner Application Data Flow Diagram

4.1.1 Functional Definition of Scanner Application Entity

The scanner includes ONE Application Entity, shall be referred as **Scanner AE** in this document.

This entity title implements all the DICOM services on the scanner. All the services are listed in the introduction section above.

The DICOM standard application context name for DICOM 3.0 is always proposed:

Table 4-1 - DICOM Application Context

Application Context Name	1.2.840.10008.3.1.1.1
--------------------------	-----------------------

4.1.2 Implementation Identifying Information

Table 4-2 - DICOM Implementation Class and Version

Application	Implementation Class UID	Implementation Version Name
Others	1.2.840	Fo-dicom 3.0.0

4.1.3 Number of Associations

Table 4-3 - Number of Associations

Maximum number of simultaneous associations	1
---	---

4.1.4 Asynchronous Nature

SW V1.3 does not support asynchronous operations communication.

4.2 Activity Verify DICOM Connection

4.2.1 SOP Classes

Arineta provides Standard Conformance to the following SOP Classes:

Table 4-4 - SOP Classes for STORAGE-SCU AE

SOP Class Name	SOP Class UID	SCU	SCP
Verification	1.2.840.10008.1.1	Yes	No

4.2.2 Association Initiation Policy

The DICOM server attempts to initiate a new association for each C-Echo attempts to send to a remote AE, when the user performs verify connection test from network preferences.

A possible sequence of interactions between the DICOM server and a remote AE (e.g., a storage or archive device supporting the both C-Echo and Storage SOP Classes as an SCP):

1. The DICOM server opens an association with a remote AE.
2. The DICOM server issues a verification request (C-ECHO) and the remote AE replies with a C-ECHO response (status success).
3. The DICOM server closes the association with the Image Manager.

5 Service and Interoperability Description

5.1 Mapping of Services to Application Entities

AE Titles, IP addresses and port numbers must be configured via the DICOM Network application. No Default parameters are provided; the configure AE Titles, IP addresses and port numbers must be configured during installation via network preferences. Different IP addresses can be configured per server in the system at the same time.

Note: All configurations should be performed by an FSE.

Table 5-1. Service to AE Mapping

Application Entity	Supported Services	Role								
		DIMSE		DICOM Web		DICOM Media			Real-Time Video	
		SCU	SCP	Origin Server	User Agent	FSC	FSU	FSR	SCU	SCP
Scanner AE	Retrieve worklist items	Y	N	N	N	N	N	N	N	N
	Storage	Y	N	N	N	N	N	N	N	N

5.2 Supported DIMSE Services

5.2.1 Basic Worklist Management Service

5.2.1.1 SCU of the Modality Worklist Information Model - FIND SOP Class

As a Service Class User of the Modality Worklist Information Model - FIND SOP Class, the Scanner uses the C-FIND-RQ message to query the SCP. It supports the Query Keys listed in Table 5-2.

In the "Matching Type" column, the following Values can be used:

- SINGLE_VALUE: SCU can request single Value matching on this Attribute.
- UID: SCU can request List of UID matching on this Attribute.
- WILDCARD: SCU can request Wildcard matching on this Attribute.
- RANGE: SCU can request Range matching on this Attribute.
- SEQUENCE: SCU can request sequence matching on this Attribute.
- UNIVERSAL: SCU can request that the Attribute be a return Value (universal matching).

In the "Query Value Source" column, the following Values can be used:

- FIXED: The query Value cannot be modified by the user or by configuration
- GENERATED: The query Value is generated by the system (e.g., current date as the study date).
- CONFIGURATION: The query Value is dependent on system configuration
- USER: The query Value is entered by the user.
- SCANNED: The query Value is read from a barcode scanner or similar device.
- EMPTY: The query Value is sent with a zero-length Value to indicate it is a return key only.

In the "Display on UI" column the following Values can be used:

- D: the return Value is displayed on the main UI by default.
- C: the return Value is displayed on the main UI if configured.
- N: the return Value is never displayed.

Table 5-2. Supported C-FIND Query Parameters for Modality Worklist - SCU

Attribute Name	Tag	Matching Type	Query Value Source	Value	Display on UI	Comments
Scheduled Procedure Step						
Scheduled Procedure Step Sequence	(0040,0100)	SEQUENCE				
>Scheduled Station AE Title	(0040,0001)	SINGLE_VALUE	GENERATED		D	AE title of the Scanner, displayed and editable as part of Scanner configuration.
Station Name						
>Scheduled Procedure StepStart date	(0040,0002)	RANGE	GENERATED		D	Current date and time minus 25 hours
>Scheduled Procedure StepStart Time	(0040,0003)	RANGE	GENERATED		D	Current date and time minus 25 hours
>Scheduled Procedure StepEnd date	(0040,0002)	RANGE	GENERATED		D	Current date and time minus 1 hour plus 24 hours ahead
>Scheduled Procedure StepEnd Time	(0040,0003)	RANGE	GENERATED		D	Current date and time minus 1 hour plus 24 hours ahead

Attribute Name	Tag	Matching Type	Query Value Source	Value	Display on UI	Comments
>Modality	(0008,0060)	SINGLE_VALUE	FIXED	CT	N	
>Scheduled PerformingPhysician's Name	(0040,0006)	UNIVERSAL	EMPTY		D	

The C-FIND CANCEL request is never issued. The C-FIND Query works with timeout. If the timeout is reached, the Scanner aborts the request and disconnects from the SCP. Operator can initiate new query from UI.

The character sets supported are negotiated as part of the C-FIND Query.

5.2.1 SCP of the Modality Worklist Information Model - FIND SOP Class (N/A)

5.2.2 Modality Performed Procedure Step Service (N/A)

5.2.3 Unified Worklist and Procedure Step Service (N/A)

5.2.4 Instance Availability Notification Service (N/A)

5.2.5 Storage Service

5.2.5.1 SCU of the Storage SOP Classes

As a Service Class User of the Storage Service Class, the Scanner uses the C-STORE-RQ message to request storage of DICOM objects by a remote SCP. See Section 1.1 Content and Transfer in the Overview for the list of supported SOP Classes.

For details regarding the content of SOP Instances that are created by the system, see Section 9, which describes the underlying IOD of the supported SOP Classes.

Automatic storage requests can be configured by the clinical user preferences, including preferred AE for some storage class attributes. Examples: SSF processing; Structured Dose report.

The automatic store is triggered by completion of the scan and images reconstruction, during the ongoing study. The X-ray Dose report storage is triggered when the study is closed and contains the accumulative data for the study.

The storage requests can be manually invoked from the Archive. The operator can initiate manual store to same or other AEs. Store can also be initiated upon "edit patient details" and "split exam" features.

5.2.5.1.1 Transcoding of Transfer Syntaxes (N/A)

5.2.5.2 SCP of the Storage SOP Classes (N/A)

5.2.6 Storage Commitment Service (N/A)

5.2.7 Query/Retrieve Service Class

5.2.7.1 SCU of the Study Root Q/R Information Model - FIND SOP Class

As a Service Class User of the Study Root Q/R - Information Model - FIND SOP Class, the Scanner uses the C-FIND-RQ message and supports the Query Keys listed in Table 5-17 for hierarchical queries.

In the "Matching Type" column the following Values can be used:

- SINGLE_VALUE: SCU can request Single Value matching on this Attribute.
- UID: SCU can request List of UID matching on this Attribute.
- WILDCARD: SCU can request Wildcard matching on this Attribute.
- RANGE: SCU can request Range matching on this Attribute.
- SEQUENCE: SCU can request Sequence matching on this Attribute.
- UNIVERSAL: SCU can request that the Attribute be a return Value (universal matching).

In the "Query Value Source" column the following Values can be used:

- FIXED: The query Value cannot be modified by the user or by configuration
- GENERATED: The query Value is generated by the system (e.g., current date as the study date).
- CONFIGURATION: The query Value is dependent on system configuration
- USER: The query Value is entered by the user.
- SCANNED: The query Value is read from a barcode scanner or similar device.
- EMPTY: The query Value is sent with a zero-length value to indicate it is a return key only.

In the "Display on UI" column the following Values can be used:

- D: the return Value is displayed on the main UI by default.
- C: the return Value is displayed on the main UI if configured.
- N: the return Value is never displayed.

Table 5-17. Supported C-FIND Attribute Matching for Study Root Q/R Model -SCU

Attribute Name	Tag	Matching Type	Query Value Source	Value	Display on UI	Comments
Study Level						
Study Date	(0008,0020)	RANGE	USER		D	

Attribute Name	Tag	Matching Type	Query Value Source	Value	Display on UI	Comments
Study Time	(0008,0030)	RANGE	USER		D	
1. ScheduledStationAETitle 2. ScheduledStationName 3. ScheduledProcedureStepStartDate 4. ScheduledProcedureStepStartTime 5. Modality						
Scheduled Procedure Step Sequence	(0040,0100)					One or more Scheduled Procedure Steps for one Requested Procedure.
>Scheduled Station AE Title	(0040,0001)					The AE title of the modality on which the Scheduled Procedure Step is scheduled to be performed.
>Scheduled Station Name	(0040,0010)					An institution defined name for the modality on which the Scheduled Procedure Step is scheduled to be performed.
>Scheduled Procedure Step Location	(0040,0011)					The location at which the Procedure Step is scheduled to be performed.
>Scheduled Procedure Step Start Date	(0040,0002)					Date on which the Scheduled Procedure Step is scheduled to start.
>Scheduled Procedure Step Start Time	(0040,0003)					Time at which the Scheduled Procedure Step is scheduled to start.
>Scheduled Procedure Step End Date	(0040,0004)					Date on which the Scheduled Procedure Step is scheduled to end.
>Scheduled Procedure Step End Time	(0040,0005)					Time at which the Scheduled Procedure Step is scheduled to end.
>Scheduled Performing Physician's Name	(0040,0006)					Name of the physician scheduled to administer the Scheduled Procedure Step.
>Scheduled Performing Physician Identification Sequence	(0040,000B)					Identification of the physician scheduled to administer the Scheduled Procedure Step. Only a single Item shall be included in this Sequence.

Table 5-17. Supported C-FIND Attribute Matching for Study Root Q/R Model -SCU

Attribute Name	Tag	Matching Type	Query Value Source	Value	Display on UI	Comments
Study Level						
Study Date	(0008,0020)	RANGE	USER		D	
Study Time	(0008,0030)	RANGE	USER		D	
Accession Number	(0008,0050)	SINGLE_VALUE	USER		D	
Patient's Name	(0010,0010)	WILDCARD	USER		D	
Patient ID	(0010,0020)	SINGLE_VALUE	USER, GENERATED		D	
Study Instance UID	(0020,000D)	UNIVERSAL	EMPTY		N	
Modalities in Study	(0008,0061)	SINGLE_VALUE	USER		D	
Study Description	(0008,1030)	WILDCARD	USER		D	
...						
Series Level						
Modality	(0008,0060)	SINGLE_VALUE	USER		D	
Body Part Examined	(0018,0015)	SINGLE_VALUE	USER		C	
...						
Instance Level						
...						
Private Attributes						
Private Creator	(0009,0010)	SINGLE_VALUE	FIXED		N	
Private Value1	(0009,1001)	UNIVERSAL	EMPTY		C	
...						

5.2.7.2 SCU of the Patient Root Q/R Information Model - FIND SOP Class

5.2.7.3 SCU of the Study Root Q/R Information Model - MOVE SOP Class

5.2.7.4 SCU of the Patient Root Q/R Information Model - MOVE SOP Class (N/A)

5.2.7.6 SCP of the Patient Root Q/R Information Model - FIND SOP Class

5.2.7.7 SCP of the Study Root Q/R Information Model - MOVE SOP Class

As the SCP of the Study Root Q/R - Information Model -MOVE, the *Scanner* receives the C-MOVE-RQ and in turn uses the C-STORE-RQ sub operation to send matching SOP Instances to the Move Destination AE included in the C-MOVE-RQ.

As the SCP of the Storage Service Class, all Storage SOP Classes listed in Section 1.1 are supported.

5.2.7.8 SCP of the Patient Root Q/R - Information Model - MOVE SOP Class

5.2.8 Print Management Service (N/A)

5.3 Supported DICOM Web Services (N/A)

5.4 Media Service

The Scanner supports export of DICOM files to an USB media, in NTFS format.

The folders' structure is described in the table below:

Folder Name/ file name	Parent folder	Folder level (from / root)	Description
<yymmdd>	/	1	Date of the export
<hhmmss>	/<yymmdd>	2	Time of the export in seconds
ST<nnnnnn>	/<hhmmss>	3	Study ID
<nnnnnn>	ST<nnnnnn>	4	Series number
I<nnnnn>	<nnnnnn>	5	DICOM image number

One media can store several “exports”. They will be identified with different time (and date).

5.5 Real Time Video Service (N/A)

5.6 Cross Service Considerations (N/A)

5.7 Specific Character Sets (N/A)

6 Configuration

Throughout all subsections the following Values can be used in the "Configurable" column:

- USER: The parameter is configurable by the user.
- SERVICE: The parameter is configurable by service personnel.
- FIXED: The parameter is not configurable (it has a fixed Value). The Value is required for the configuration of the remote system.
- N/A: The parameter is not applicable for the local or the remote system.

6.1 General Configuration Parameters

The scanner uses 3rd party component to implement DICOM Store SCU. For details refer to <https://support.dcmk.org/docs/storescu.html>.

Table 6-1. General Configuration Parameters

Parameter	Configurable	Default Value	Comments
<i>Called AET</i>	<i>USER</i>		<i>The destination AET is defined by the user as part of system preferences</i>
General Parameters			
Timeout waiting for acceptance or rejection Response to an Association Open Request. (Application-Level timeout)	FIXED	5 sec	
<i>General DIMSE level timeout Values</i>			
TCP/IP Settings			
<i>TCP/IP Send Buffer</i>	<i>SERVICE</i>	<i>65535 Bytes</i>	<i>Min: 16Kb, Max: 128Kb</i>
<i>TCP/IP Receive Buffer</i>	<i>FIXED</i>	<i>65535 Bytes</i>	
DICOM Services Parameters			
Maximum number of simultaneous Associations accepted	Not SCP		
Specific Character Set			See supported character sets section
<i>Other parameters</i>			

Table 6-1 lists general configuration parameters applicable across all supported DICOM Services.

Table 6-1. General Configuration Parameters

Parameter	Configurable	Default Value	Comments
General Parameters			
Timeout waiting for acceptance or rejection Response to an Association Open Request. (Application-Level timeout)			
Timeout waiting for a response to an Association release request (Application Level Timeout)			
<i>General DIMSE level timeout Values</i>			
TCP/IP Settings			
TCP/IP Send Buffer	SERVICE	65535 Bytes	Min: 16Kb, Max: 128Kb
TCP/IP Receive Buffer	FIXED	65535 Bytes	
DICOM Services Parameters			
Maximum number of simultaneous Associations accepted			
Specific Character Set			
<i>Other parameters</i>			

6.2 Configuration of DIMSE Services

The tables in the following subsections show the configuration parameters required for DIMSE Services.

In order to identify whether *Scanner* is an SCP and / or an SCU, the following applies:

- SCP: The (Secured) Local Called AET and Remote Calling AET parameters are present.
- SCU: The (Secured) Local Calling AET and Remote Called AET parameters are present.

Local Configuration Parameters - <service name>			
Parameter	Configurable	Default Value	Comments
Calling AE Title (SCU)			
Called AE Title (SCP)			
Port			
TLS-Secured Port			

Local Configuration Parameters - <service name>			
Parameter	Configurable	Default Value	Comments
<Specific service parameter>			
Remote Configuration Parameters - <service name>			
Parameter	Configurable	Default Value	Comments
Calling AE Title (SCU)			
Called AE Title (SCP)			
Port			
TLS-Secured Port			
Host			
<Specific service parameters>			

- 6.2.1 Basic Worklist Management Service Configuration (N/A)
- 6.2.2 Modality Performed Procedure Step Service Configuration (N/A)
- 6.2.3 Unified Worklist and Procedure Step Service Configuration (N/A)
- 6.2.4 Instance Availability Notification Service Configuration (N/A)
- 6.2.5 Storage Service Configuration (N/A)
- 6.2.6 Storage Commitment Service Configuration (N/A)
- 6.2.7 Query/Retrieve Service Configuration (N/A)
- 6.2.8 Print Management Service Configuration (N/A)
- 6.3 Configuration of DICOM Web Services (N/A)
 - 6.3.1 URI Web Service Configuration (N/A)
 - 6.3.2 Studies Web Service Configuration (N/A)
 - 6.3.3 Worklist Web Service Configuration (N/A)
 - 6.3.4 Non-Patient Instances (NPI) Web Service Configuration (N/A)
- 6.4 Configuration of Media Storage Service (N/A)
- 6.5 Configuration of Real Time Video Service (N/A)
- 6.6 Configuration of Audit Trail – Syslog (N/A)

7 Network and Media Communication Details

7.1 General

The cross interaction between the AEs is depicted in the diagrams below.

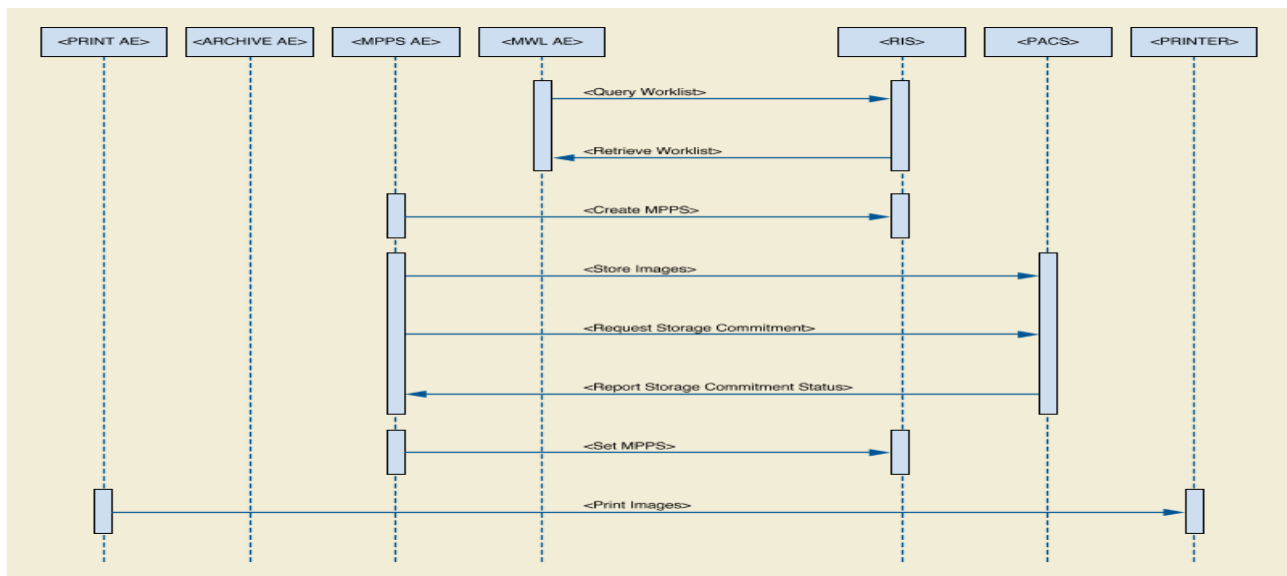

Figure 7-1. Real-World Activity and Cross AE interaction

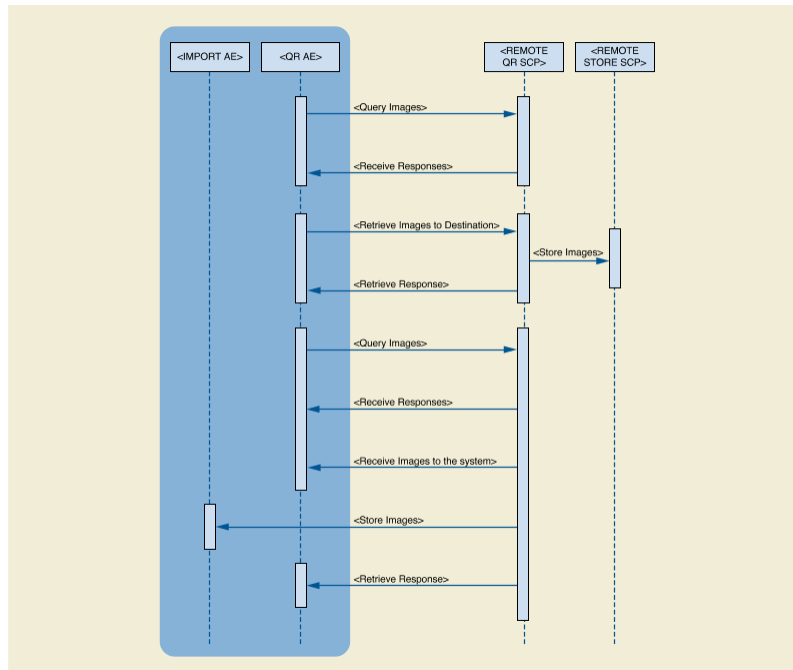

Figure 7-2. Real-World Activity and Cross AE interaction - Query Retrieve

7.1.1 General Association Parameters

Table 7-1 lists Association parameters applicable to all AEs on the system.

Table 7-1. General Association Parameters

	Name	Value
Networking Services	Application Context Name	1.2.840.10008.3.1.1.1
	Implementation Class UID	
	Implementation Version Name	
	Maximum PDU Length	<i>Default: 4096</i>
	ARTIM Timeout	<i>Default: 30s</i>
	Maximum number of simultaneous Associations as Association Initiator	
	Maximum number of simultaneous Associations as Association Acceptor	
	Maximum number of outstanding asynchronous Transactions	
Media Services	File Meta Information Version	

	Name	Value
	Implementation Class UID	
	Implementation Version Name	
Web Services	Maximum number of connections supported as Server	

7.2 Specifications

7.2.1 <AE1> Application Entity

7.2.1.1 Sequencing of Real-World Activities for <AE1>

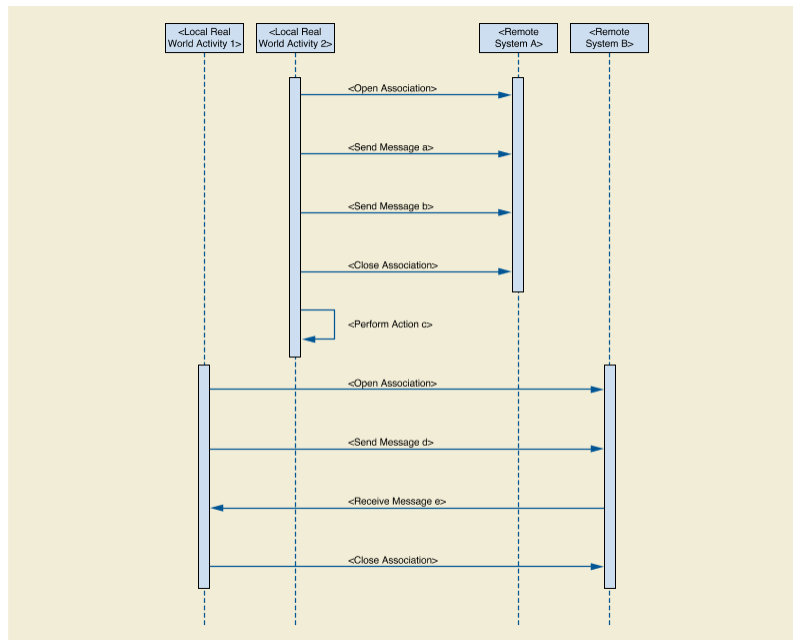

Figure 7-3. Sequencing of Real-World Activities for <AE1>

Also include its use of DICOM-RTV Services, including any proxy functionality between a DICOM-RTV and another service provided through DIMSE Service or RESTful (i.e., storage of received video and audio with associated metadata).

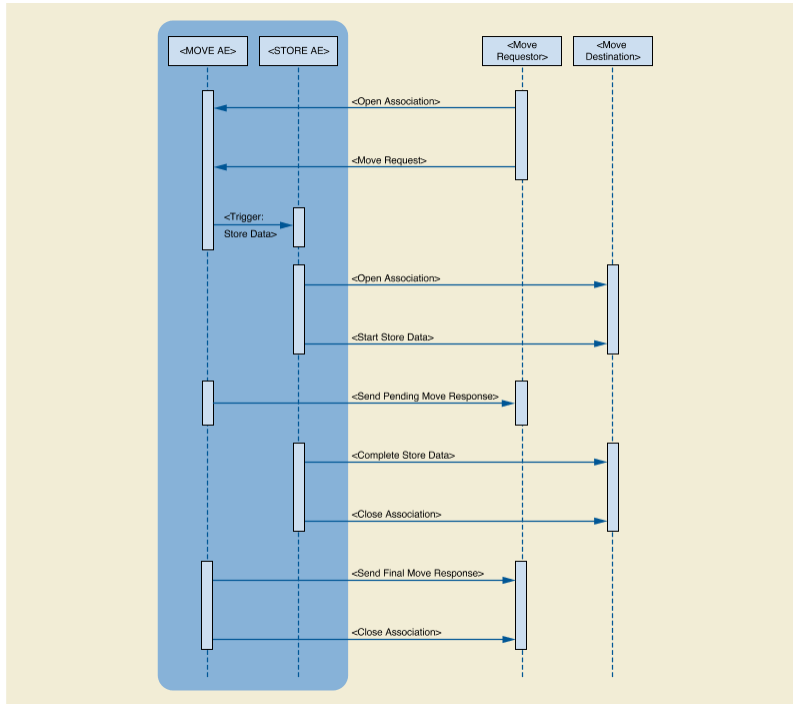

Figure 7-4. Sequencing of Real-World Activities for <QueryRetrieve AE>

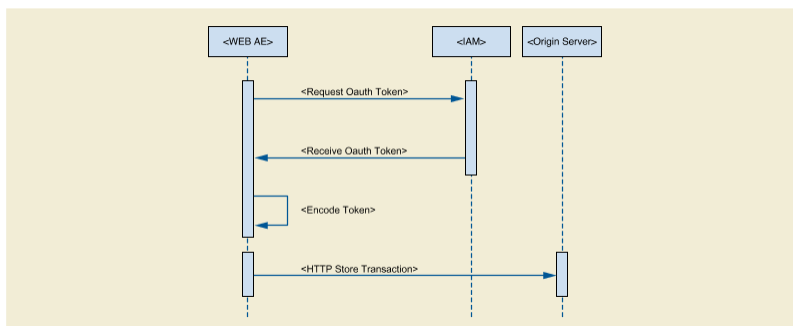

Figure 7-5. Sequencing of Real-World Activities for <Web AE>

7.2.1.2 Association Parameters of <AE1>

Table 7-2 lists Association parameters applicable to <AE1.>

Table 7-2. Association Parameters for <AE1>

	Name	Value
Networking Services	Application Context Name	1.2.840.10008.3.1.1.1
	Implementation Class UID	

	Name	Value
	Implementation Version Name	
	Maximum PDU Length	Default: 4096
	ARTIM Timeout	Default: 30s
	Maximum number of simultaneous Associations as Association Initiator	
	Maximum number of simultaneous Associations as Association Acceptor	
	Maximum number of outstanding asynchronous Transactions	
Media Services	File Meta Information Version	
	Implementation Class UID	
	Implementation Version Name	
Web Services	Maximum number of connections supported as Server	

7.2.1.3 Association Initiation

This section details the Association policies of the Application Entity when it is initiating an Association

7.2.1.3.1 Real-World Activity <Activity 1>

Extended Negotiation

The Extended Negotiation parameters for all services that are supported by the Application Entity for the Real-World Activity <Activity 1> are described in Table 7-3.

Table 7-3. Extended Negotiation for <Activity 1> of <AE1> - Association Initiation

SOP Class	Extended Negotiation	Support	Requested Value
Modality Worklist			
Modality Worklist Information Model - FIND	Fuzzy semantic matching of person names		<0,1>
	Timezone query adjustment		<0,1>
Storage			
Applicable to all Storage SOP Classes listed under Section 5.	Level of support		<3>
	Level of Digital Signature support		<(0),1,2,3>
	Element Coercion		<0,1,(2) >
Query			

SOP Class	Extended Negotiation	Support	Requested Value
Applicable to all Query Retrieve - FIND SOP Classes mentioned under Section 5.	Relational queries		<0,1>
	Date-time matching		<0,1>
	Fuzzy semantic matching of person names		<0,1>
	Timezone query adjustment		<0,1>
	Enhanced Multi-Frame Image Conversion		<0,1>
Retrieve			
Applicable to all Query Retrieve - MOVE SOP Classes mentioned under Section 5.	Relational retrieval		<0,1>
	Enhanced Multi-Frame Image Conversion		<0,1>
	Timezone query adjustment		1
Unified Worklist and Procedure Step			
Unified Worklist and Procedure Step	Fuzzy semantic matching of person names		<0,1>
	Timezone query adjustment		<0,1>

7.2.1.4 Association Acceptance

This section details the Association policies of the Application Entity when it is the acceptor of an Association

7.2.1.4.1 Real-World Activity <Activity 2>

Extended Negotiation

The Extended Negotiation parameters for all services that are requested by the Application Entity for the Real-World Activity <Activity 2> are described in Table 7-4.

Table 7-4. Extended Negotiation for <Activity 2> of <AE1> - Association Acceptance

SOP Class	Extended Negotiation	Support	Requested Value
Modality Worklist			
Modality Worklist Information Model - FIND (1.2.840.10008.5.1.4.31)	Fuzzy semantic matching of person names		<0,1>
	Timezone query adjustment		<0,1>
Storage			
Applicable to all Storage SOP Classes listed under Section 5.	Level of support		<0,1,2,(3) >
	Level of Digital Signature support		<(0) ,1,2,3>

SOP Class	Extended Negotiation	Support	Requested Value
	Element Coercion		<0,1,(2)>
Query			
Applicable to all Query Retrieve - FIND SOP Classes mentioned under Section 5.	Relational queries		<0,1>
	Date-time matching		<0,1>
	Fuzzy semantic matching of person names		<0,1>
	Timezone query adjustment		<0,1>
	Enhanced Multi-Frame Image Conversion		<0,1>
Retrieve			
Applicable to all Query Retrieve - MOVE SOP Classes mentioned under Section 5.	Relational retrieval		<0,1>
	Enhanced Multi-Frame Image Conversion		<0,1>
	Timezone query adjustment		<1>
Unified Worklist and Procedure Step			
Unified Worklist and Procedure Step	Fuzzy semantic matching of person names		<0,1>
	Timezone query adjustment		<0,1>

Transfer Syntax Selection Policies

This section provides tables that describe the Transfer Syntax preference for different SOP Classes or SOP Class groups when there are multiple Transfer Syntaxes provided by the Association initiator for Real-World Activity <Activity 2> of <AE1> of the system.

Table 7-5. Transfer Syntax Selection Preference Order - Image SOP Classes for <AE1>

Preference Order	Transfer Syntax	UID	Comments
1	JPEG Lossless, Hierarchical, First-Order Prediction Transfer Syntax	1.2.840.10008.1.2.4.70	
2	RLE Lossless	1.2.840.10008.1.2.5	
3	Explicit VR Little-Endian Transfer Syntax	1.2.840.10008.1.2.1	
4	Implicit VR Little-Endian Transfer Syntax	1.2.840.10008.1.2	
5	Explicit VR Big-Endian Transfer Syntax	1.2.840.10008.1.2.2	

Table 7-6. Transfer Syntax Selection Preference Order - Video SOP Classes for <AE1>

Preference Order	Transfer Syntax	UID	Comments
1	MPEG2 Main Profile / Main Level	1.2.840.10008.1.2.4.100	
2	MPEG-4 AVC/H.264 Stereo High Profile / Level 4.2	1.2.840.10008.1.2.4.106	
3	Explicit VR Little-Endian Transfer Syntax	1.2.840.10008.1.2.1	
4	Implicit VR Little-Endian Transfer Syntax	1.2.840.10008.1.2	
5	Explicit VR Big-Endian Transfer Syntax	1.2.840.10008.1.2.2	

Table 7-7. Transfer Syntax Selection Preference Order - Non-Image SOP Classes for <AE1>

Preference Order	Transfer Syntax	UID	Comments
1	Explicit VR Little-Endian Transfer Syntax	1.2.840.10008.1.2.1	
2	Implicit VR little-Endian Transfer Syntax	1.2.840.10008.1.2	
3	Explicit VR Big-Endian Transfer Syntax	1.2.840.10008.1.2.2	

7.3 Status Codes

The following sections describe the Status Codes supported by the system for each implemented service as well as the reason for issuing specific Status codes or the associated behavior when receiving it.

7.3.1 General AE Communication and Failure Behavior and Handling

7.3.1.1 Communication Failure Behavior as Association Initiator

Table 7-8 describes behavior of the AE if a communication failure occurs when it initiated an Association

Table 7-8. DICOM Communication Failure Behavior as Association Initiator

Failure	Failure Behavior
Timeout	
Association aborted	
Network Disconnect	

7.3.1.2 Communication Failure Handling as Association Acceptor

Table 7-9 describes how the AE responds when it receives an Association request that leads to a failure in communication

Table 7-9. DICOM Communication Failure Handling as Association Acceptor

Exception	Failure response
Failure during processing of an Association request	
Unrecognized Called AE	
Exceed limit for number of connections supported	

7.3.2 DIMSE Services

7.3.2.1 Basic Worklist Management Service

7.3.2.1.1 SCU of the Modality Worklist Information Model Find SOP Class - C-FIND

Table 7-10 lists the Status Codes that the SCU of the Modality Worklist Information Model Find SOP Class supports for the C-FIND message and defines the application behavior when encountering the listed Status Codes.

Table 7-10. Status Codes for C-FIND of the Modality Worklist Information Model SOP Class - SCU

Service Status	Further Meaning	Status Code	Behavior
Success	Matching is complete - No final identifier is supplied	0000	
Failure	Refused: Out of Resources	A700	
	SOP Class Not Supported	0122	
	Error: Data Set does not match SOP Class	A900	
	Error: Unable to process	C000-CFFF	
Cancel	Matching terminated due to cancel	FE00	
Pending	Matches are continuing - Current Match is supplied and any Optional Keys were supported in the same manner as Required Keys.	FF00	
	Matches are continuing - Warning that one or more Optional Keys were not supported for existence for this Identifier	FF01	
-	Other status codes	anything else	

7.3.2.1.2 SCP of the Modality Worklist Information Model Find SOP Class - C-FIND (N/A)

7.3.2.2 Modality Performed Procedure Step Service (N/A)

7.3.2.3 Unified Worklist and Procedure Step Service (N/A)

7.3.2.4 Instance Availability Notification Service (N/A)

7.3.2.5 Storage Service

7.3.2.5.1 SCU of the Storage SOP Classes - C-STORE

Table 7-42 lists the Status Codes that the SCU of the Storage SOP Class supports for the C-STORE message and defines the application behavior when encountering the listed Status Codes.

Table 7-42. Status Codes C-STORE for the Storage SOP Classes - SCU

Service Status	Further Meaning	Status Code	Behavior
Success	Success	0000	
Warning	Coercion of Data Elements	B000	
	Data Set does not match SOP Class	B007	
	Elements Discarded	B006	
Failure	SOP Class not supported	0112	
	Invalid SOP Instance	0117	
	Duplicate Invocation	0210	
	Unrecognized Operation	0211	
	Mistyped Argument	0212	
	Not authorized	0214	
	Out of Resources	A700-A7FF	
	Data Set does not match SOP Class	A900-A9FF	
	Cannot Understand	C000-CFFF	
-	Other status codes	anything else	

7.3.2.5.2 SCP of the Storage SOP Classes - C-STORE (N/A)
7.3.2.6 Storage Commitment Service (N/A)
7.3.2.7 Query/Retrieve Service
7.3.2.7.1 SCU of the Query/Retrieve FIND SOP Classes - C-FIND

Table 7-48 lists the Status Codes that the SCU of any of the Query/Retrieve FIND SOP Class supports for the C-FIND message and defines the application behavior when encountering the listed Status Codes.

Table 7-48. Status Codes C-FIND for Query/Retrieve FIND SOP Classes - SCU

Service Status	Further Meaning	Status Code	Behavior
Success	Matching is complete - No final identifier is supplied	0000	
Failure	Refused: Out of Resources	A700	
	Error: Data Set does not match SOP Class	A900	

Service Status	Further Meaning	Status Code	Behavior
	Error: Unable to process	C000-CFFF	
	SOP Class Not Supported	0122	
Cancel	Matching terminated due to cancel	FE00	
Pending	Matches are continuing - Current Match is supplied and any Optional Keys were supported in the same manner as Required Keys.	FF00	
	Matches are continuing - Warning that one or more Optional Keys were not supported for existence for this Identifier	FF01	
-	Other status codes	anything else	

7.3.2.7.2 SCU of the Query/Retrieve MOVE SOP Classes - C-MOVE (N/A)

7.3.2.7.3 SCP of the Query/Retrieve FIND SOP Classes - C-FIND (N/A)

7.3.2.7.4 SCP of the Query/Retrieve MOVE SOP Classes - C-MOVE (N/A)

7.3.2.8 Print Management Service N/A

7.3.3 DICOM Web Services N/A

7.3.3.4 Worklist Web Service

7.3.3.4.1 Create Transaction as Origin Server

Table 7-98 lists the Status Codes that an origin server supports for the Create Transaction of the Worklist Web Service and the conditions in which the listed Status Codes are sent:

Table 7-98. Status Codes of Origin Server for Create Transaction

Status	Code	Condition
Success	201 (Created)	
Failure	400 (Bad Request)	
	409 (Conflict)	

7.3.3.4.2 Create Transaction as User Agent

Table 7-99 lists the Status Codes that a user agent supports for the Create Transaction of the Worklist Web Service and defines the application behavior when encountering the listed Status Codes:

Table 7-99. Status Codes of User Agent for Create Transaction

Status	Code	Behavior
Success	201 (Created)	

Status	Code	Behavior
Failure	400 (Bad Request)	
	409 (Conflict)	
-	Other status codes	

7.3.3.4.3 Retrieve Workitem Transaction as Origin Server

Table 7-100 lists the Status Codes that an origin server supports for the Retrieve Workitem Transaction of the Worklist Web Service and the conditions in which the listed Status Codes are sent:

Table 7-100. Status Codes of Origin Server for Retrieve Workitem Transaction

Status	Code	Condition
Success	200 (OK)	
Failure	400 (Bad Request)	
	404 (Not Found)	
	409 (Conflict)	
	410 (Gone)	

7.3.3.4.4 Retrieve Workitem Transaction as User Agent

Table 7-101 lists the Status Codes that a user agent supports for the Retrieve Workitem Transaction of the Worklist Web Service and defines the application behavior when encountering the listed Status Codes:

Table 7-101. Status Codes of User Agent for Retrieve Workitem Transaction

Status	Code	Behavior
Success	200 (OK)	
Failure	400 (Bad Request)	
	404 (Not Found)	
	409 (Conflict)	
	410 (Gone)	
-	Other status codes	

7.3.3.4.5 Update Workitem Transaction as Origin Server

Table 7-102 lists the Status Codes that an origin server supports for the Update Workitem Transaction of the Worklist Web Service and the conditions in which the listed Status Codes are sent:

Table 7-102. Status Codes of Origin Server for Update Workitem Transaction

Status	Code	Condition
Success	200 (OK)	
Failure	400 (Bad Request)	
	404 (Not Found)	
	409 (Conflict)	
	410 (Gone)	

7.3.3.4.6 Update Workitem Transaction as User Agent

Table 7-103 lists the Status Codes that a user agent supports for the Update Workitem Transaction of the Worklist Web Service and defines the application behavior when encountering the listed Status Codes:

Table 7-103. Status Codes of User Agent for Update Workitem Transaction

Status	Code	Behavior
Success	200 (OK)	
Failure	400 (Bad Request)	
	404 (Not Found)	
	409 (Conflict)	
	410 (Gone)	
-	Other status codes	

7.3.3.4.7 Change Workitem State Transaction as Origin Server

Table 7-104 lists the Status Codes that an origin server supports for the Change Workitem State Transaction of the Worklist Web Service and the conditions in which the listed Status Codes are sent:

Table 7-104. Status Codes of Origin Server for Change Workitem State Transaction

Status	Code	Condition
Success	200 (OK)	
Failure	400 (Bad Request)	
	404 (Not Found)	
	409 (Conflict)	

Status	Code	Condition
	410 (Gone)	

7.3.3.4.8 Change Workitem State Transaction as User Agent

Table 7-105 lists the Status Codes that a user agent supports for the Change Workitem Transaction of the Worklist Web Service and defines the application behavior when encountering the listed Status Codes:

Table 7-105. Status Codes of User Agent for Change Workitem State Transaction

Status	Code	Behavior
Success	200 (OK)	
Failure	400 (Bad Request)	
	404 (Not Found)	
	409 (Conflict)	
	410 (Gone)	
-	Other status codes	

7.3.3.4.9 Request Cancellation Transaction as Origin Server

Table 7-106 lists the Status Codes that an origin server supports for the Request Cancellation of the Worklist Web Service and the conditions in which the listed Status Codes are sent:

Table 7-106. Status Codes of Origin Server for Request Cancellation Transaction

Status	Code	Condition
Success	202 (Accepted)	
Failure	400 (Bad Request)	
	404 (Not Found)	
	409 (Conflict)	

7.3.3.4.10 Request Cancellation Transaction as User Agent

Table 7-107 lists the Status Codes that a user agent supports for the Request Cancellation Transaction of the Worklist Web Service and defines the application behavior when encountering the listed Status Codes:

Table 7-107. Status Codes of User Agent for Request Cancellation Transaction

Status	Code	Behavior
Success	202 (Accepted)	

Status	Code	Behavior
Failure	400 (Bad Request)	
	404 (Not Found)	
	409 (Conflict)	
-	Other status codes	

7.3.3.4.11 Search Transaction as Origin Server

Table 7-108 lists the Status Codes that an origin server supports for the Search Transaction of the Worklist Web Service and the conditions in which the listed Status Codes are sent:

Table 7-108. Status Codes of Origin Server for Search Transaction

Status	Code	Condition
Success	200 (OK)	
	204 (No Content)	
	206 (Partial Content)	
Failure	400 (Bad Request)	
	413 (Payload Too Large)	

7.3.3.4.12 Search Transaction as User Agent

Table 7-109 lists the Status Codes that a user agent supports for the Search Transaction of the Worklist Web Service and defines the application behavior when encountering the listed Status Codes:

Table 7-109. Status Codes of User Agent for Search Transaction

Status	Code	Behavior
Success	200 (OK)	
	204 (No Content)	
	206 (Partial Content)	
Failure	400 (Bad Request)	
	413 (Payload Too Large)	
-	Other status codes	

7.3.3.4.13 Subscribe Transaction as Origin Server

Table 7-110 lists the Status Codes that an origin server supports for the Subscribe Transaction of the Worklist Web Service and the conditions in which the listed Status Codes is sent:

Table 7-110. Status Codes of Origin Server for Subscribe Transaction

Status	Code	Condition
Success	201 (Created)	
Failure	400 (Bad Request)	
	403 (Forbidden)	
	404 (Not Found)	

7.3.3.4.14 Subscribe Transaction as User Agent

Table 7-111 lists the Status Codes that a user agent supports for the Subscribe Transaction of the Worklist Web Service and defines the application behavior when encountering the listed Status Codes:

Table 7-111. Status Codes of User Agent for Subscribe Transaction

Status	Code	Behavior
Success	201 (Created)	
Failure	400 (Bad Request)	
	403 (Forbidden)	
	404 (Not Found)	
-	Other status codes	

7.3.3.4.15 Unsubscribe Transaction as Origin Server

Table 7-112 lists the Status Codes that an origin server supports for the Unsubscribe Transaction of the Worklist Web Service and the conditions in which the listed Status Codes are sent:

Table 7-112. Status Codes of Origin Server for Unsubscribe Transaction

Status	Code	Condition
Success	200 (OK)	
Failure	400 (Bad Request)	
	404 (Not Found)	

7.3.3.4.16 Unsubscribe Transaction as User Agent

Table 7-113 lists the Status Codes that a user agent supports for the Unsubscribe Transaction of the Worklist Web Service and defines the application behavior when encountering the listed Status Codes:

Table 7-113. Status Codes of User Agent for Unsubscribe Transaction

Status	Code	Behavior
Success	200 (OK)	
Failure	400 (Bad Request)	
	404 (Not Found)	
-	Other status codes	

7.3.3.4.17 Suspend Global Subscription Transaction as Origin Server

Table 7-114 lists the Status Codes that an origin server supports for the Suspend Global Subscription Transaction of the Worklist Web Service and the conditions in which the listed Status Codes are sent:

Table 7-114. Status Codes of Origin Server for Suspend Global Subscription Transaction

Status	Code	Condition
Success	200 (OK)	
Failure	400 (Bad Request)	
	404 (Not Found)	

7.3.3.4.18 Suspend Global Subscription Transaction as User Agent

Table 7-115 lists the Status Codes that a user agent supports for the Suspend Global Subscription Transaction of the Worklist Web Service and defines the application behavior when encountering the listed Status Codes:

Table 7-115. Status Codes of User Agent for Suspend Global Subscription Transaction

Status	Code	Behavior
Success	200 (OK)	
Failure	400 (Bad Request)	
	404 (Not Found)	
-	Other status codes	

7.3.3.5 Non-Patient Instance Web Service
7.3.3.5.1 Retrieve Transaction as Origin Server

Table 7-116 lists the Status Codes that an origin server supports for the Retrieve Transaction of the Non-Patient Instance Web Service and the conditions in which the listed Status Codes are sent:

Table 7-116. Status Codes of Origin Server for Retrieve Transaction

Status	Code	Condition
Success	200 (OK)	
Failure	400 (Bad Request)	
	404 (Not Found)	
	406 (Unsupported Media Type)	

7.3.3.5.2 Retrieve Transaction as User Agent

Table 7-117 lists the Status Codes that a user agent supports for the Retrieve Transaction of the Non-Patient Instance Web Service and defines the application behavior when encountering the listed Status Codes:

Table 7-117. Status Codes of User Agent for Retrieve Transaction

Status	Code	Behavior
Success	200 (OK)	
Failure	400 (Bad Request)	
	404 (Not Found)	
	406 (Unsupported Media Type)	
-	Other status codes	

7.3.3.5.3 Store Transaction as Origin Server

Table 7-118 lists the Status Codes that an origin server supports for the Store Transaction of the Non-Patient Instance Web Service and the conditions in which the listed Status Codes are sent:

Table 7-118. Status Codes of Origin Server for Search Transaction

Status	Code	Condition
Success	200 (OK)	
	202 (Accepted)	
Failure	400 (Bad Request)	
	404 (Not Found)	
	409 (Conflict)	
	415 (Unsupported Media Type)	

7.3.3.5.4 Store Transaction as User Agent

Table 7-119 lists the Status Codes that a user agent supports for the Store Transaction of the Non-Patient Instance Web Service and defines the application behavior when encountering the listed Status Codes:

Table 7-119. Status Codes of User Agent for Store Transaction

Status	Code	Behavior
Success	200 (OK)	
	202 (Accepted)	
Failure	400 (Bad Request)	
	404 (Not Found)	
	409 (Conflict)	
	415 (Unsupported Media Type)	
-	Other status codes	

7.3.3.5.5 Search Transaction as Origin Server

Table 7-120 lists the Status Codes that an origin server supports for the Search Transaction of the Non-Patient Instance Web Service and the conditions in which the listed Status Codes are sent:

Table 7-120. Status Codes of Origin Server for Search Transaction

Status	Code	Condition
Success	200 (OK)	
Failure	406 (Unsupported Media Type)	
	413 (Payload Too Large)	

7.3.3.5.6 Search Transaction as User Agent

Table 7-121 lists the Status Codes that a user agent supports for the Search Transaction of the Non-Patient Instance Web Service and defines the application behavior when encountering the listed Status Codes:

Table 7-121. Status Codes of User Agent for Search Transaction

Status	Code	Behavior
Success	200 (OK)	
Failure	406 (Unsupported Media Type)	
	413 (Payload Too Large)	
-	Other status codes	

8 Security

8.1 Introduction

The security section describes security features implemented by this product. It includes descriptions of non-DICOM network protocols, information to configure firewalls and application whitelists, lists of supported DICOM security profiles as well as Web Security features. Additionally, secured media storage, VPN, etc. are also specified in this security section.

8.2 External Network Requirements

Table 8-1 describes additional non-DICOM network protocols that are used by Scanner.

The Scanner is based on Windows 10 OS. In the table below, the “Security Support” column is listed as No, but Windows 10 is one of the recent OS implementations and it is assumed to include security support for the attached list of actors.

Table 8-1. External Network Requirements

Profile	Actor	Transaction	Protocol Used	RFCs	Security Support	Reference section
Basic Time Synchronization	NTP Server	Maintain Time	NTP	RFC5905; <<RFC5906 RFC8633>>	N	N.11.1.1
		Find NTP Servers	NTP	RFC5905; <<RFC5906 RFC8633>>		N.11.1.1
	NTP Client	Maintain Time	NTP	RFC5905; <<RFC5906 RFC8633>>	N	N.11.1.1
		Find NTP Servers	NTP	RFC5905; <<RFC5906 RFC8633>>		N.11.1.1
	SNTP Client	Maintain Time	SNTP	RFC2030		N.11.1.1
	DHCP Server	Find NTP Servers	DHCP	RFC2131; RFC2132; RFC2563		N.11.1.1
	DHCP Client	Find NTP Servers	DHCP	RFC2131; RFC2132; RFC2563	N	N.11.1.1
	Basic Network Address Management	DHCP Server	Configure DHCP Server	-	-	
		Find and Use DHCP Server	DHCP	RFC2131; RFC2132; RFC2563		N.11.1.2
		Maintain Lease	DCP	RFC2131; RFC2132		N.11.1.2
		Resolve Hostname	DNS	RFC1035; RFC2181		N.11.1.2
		DDNS Coordination	DNS	RFC2136		N.11.1.2
DHCP Client		Find and Use DHCP Server	DHCP	RFC2131; RFC2132; RFC2563	N	N.11.1.2
		Maintain Lease	DHCP	RFC2131; RFC2132	N	N.11.1.2
DNS Server		DNS Coordination	DNS	RFC2136; <<RFC4033 RFC4034 RFC4035>>		N.11.1.2
		Resolve Hostname	DNS	RFC1035; RFC2181; <<RFC4033 RFC4034 RFC4035>>		N.11.1.2

Profile	Actor	Transaction	Protocol Used	RFCs	Security Support	Reference section
	DNS Client	Resolve Hostname	DNS	RFC1035; RFC2181; <<RFC4033 RFC4034 RFC4035>>		N.11.1.2
Application Configuration Management	LDAP Server	Query LDAP Server	LDAP	RFC2251		N.11.1.3
		Update LDAP Server	LDAP	RFC2251		N.11.1.3
		Maintain LDAP Server	LDAP	RFC2849		N.11.1.3
	LDAP Client	Find LDAP Server	LDAP	RFC2181; RFC2219; RFC2782	N	N.11.1.3
		Query LDAP Server	LDAP	RFC2251	N	N.11.1.3
		Update LDAP Server	LDAP	RFC2251		N.11.1.3
	DNS Server	Find LDAP Server	LDAP	RFC2181; RFC2219; RFC2782		N.11.1.3
DNS Service Discovery	DNS Server	Find DICOM Service	DNS	RFC2136; RFC2181; RFC2219; RFC2782; RFC6762; RFC6763; RFC8553; <<RFC4033 RFC4034 RFC4035>>		N.11.1.4
	DNS Client	Find DICOM Service	DNS	RFC2136; RFC2181; RFC2219; RFC2782; RFC6762; RFC6763; RFC8553; <<RFC4033 RFC4034 RFC4035>>		N.11.1.4
<i>[Any additional profile]</i>						

8.3 TCP Port Configuration

See Section 6 Configuration for information on the usage of ports for DICOM and other protocols. This section contains helpful information for product administrators to configure firewalls, application whitelists, etc.

8.4 DICOM Security Profiles Support

8.4.1 Secure Use and User Identity Profiles

Table 8-2 lists the Secure Use and User Identity Profiles:

Table 8-2. Secure Use and User Identity Profiles

Profile	Creator/Sender	Consumer/Receiver	Reference
Online Electronic Storage Secure Use	N	N	11.2.1
Audit Trail Message Format	N		11.2.2
Audit Trail Message Transmission Profile - SYSLOG-TLS	N		11.2.3
Audit Trail Message Transmission Profile - SYSLOG-UDP	N		11.2.4
Basic User Identity Association	N		8.5
User Identity Plus Passcode Association	N		8.5
Kerberos Identity Negotiation Association	N		8.5
Generic SAML Assertion Identity Negotiation Association	N		8.5

8.4.2 Secure Transport Connection Profiles

Table 8-3 describes the Secure Transport Connection Profiles supported by the product. Accepted cipher suites are described in the section listed in the "Reference" column

Table 8-3. Secure Transport Connection Profiles

Profile	Secured AE	Sender	Receiver	Reference
BCP 195 RFC 8996 TLS Secure Transport Connection Profile	N/A			11.2.5
Modified BCP 195 RFC 8996 TLS Secure Transport Connection Profile	N/A			11.2.5

8.4.3 Media Storage Security Profiles

See Section 1.4 Media Services for information on supported secured Application Profiles and secured media.

Table 8-4 details the encryption mechanisms that are supported with secure media.

Table 8-4. Content Encryption used for Secured Media

Encryption	File Set Creator/File Set Updater	File Set Reader
AES		
Triple-DES		
[Other encryption]		

Table 8-5. Content Types used for Secured Media

Content Types	File Set Creator/File Set Updater	File Set Reader
Signed-data		
Digested-data		
[Other content type]		

Table 8-6. Digest Algorithms used for Secured Media

Digest Algorithms	File Set Creator/File Set Updater	File Set Reader
SHA-1		
SHA256		
SHA384		
SHA512		
[Other digest algorithm]		

8.4.4 Attribute Confidentiality Profiles

Table 8-7 lists supported Attribute Confidentiality Profiles and options:

Table 8-7. Attribute Confidentiality Profiles

Profile	Option	AE	De-identifier	Re-identifier	Configurable
Basic Application Level Confidentiality					
	Basic Profile				
	Clean Pixel Data				
	Clean Recognizable Visual Features				
	Clean Graphics				

Profile	Option	AE	De-identifier	Re-identifier	Configurable
	Clean Structured Content				
	Clean Descriptors				
	Retain Longitudinal Temporal Information with Full Dates				
	Retain Longitudinal Temporal Information with Modified Dates				
	Retain Patient Characteristics				
	Retain Device Identity				
	Retain Institution Identity				
	Retain UIDs				
	Retain Safe Private				

See Section 11.2.6 for implementation details.

8.4.5 Digital Signature Profiles (N/A)

8.4.6 Additional DICOM Security Profiles (N/A)

8.5 User Identity Negotiation Support (N/A)

8.6 Web Services Security Features (N/A)

8.7 Other Security Features (N/A)

9 Annexes

Annex A. Information Object Definitions (IODs)

This section describes all the SOP Instances natively created by *Scanner*, e.g., images created by an acquisition modality or evidence documents created on a review workstation (i.e., all SOP Classes that are marked in the "Created" column in Table 1-1). Details on Attribute coercion are defined in Section 5.2.5.2.

In the "Source" column, the following Values can be used:

- FIXED: The Value is pre-defined and cannot be modified.
- GENERATED: The Value is generated by the system.
- CONFIGURATION: The Value is copied from the system configuration.
- MWL: The Value is copied from a Modality Worklist entry.
- QUERY: The Value is determined by performing a query of any of the supported Query/Retrieve Services.
- USER: The Value is entered by the user.

- SCANNED: The Value is read from a barcode scanner or similar device.
- EMPTY: The Attribute is sent with a zero-length Value.
- SRC_INSTANCE: The Value is copied from previously created/received SOP Instances.

The "Presence" columns reflect the usage of the Module, Functional Group Macro, Attributes, or Value in the *Scanner* Implementation and is not necessarily the same as defined in the DICOM Standard. For the "Presence" column the following Values can be used:

- ALWAYS: the module, functional group macro, Attributes or Value is always present.
- CONDITIONAL: the presence of the module, functional group macro, Attributes or Value is dependent on a condition. The condition must be listed in the "Conditions" column.
- SRC_COPY: The presence of the Attributes and Values depends on the availability of these in the source instances, which are used for copying this information.
- EMPTY: The Attribute is present but without a Value (zero length).

9.A.2 Information Shared Across Multiple IODs

9.A.2.1 Common Modules

All SOP Instances generated by the system use the common modules listed in Table 9-1 to Table 9-12 or a subset of them, as defined in the IOD specific subsections below.

Table 9-1. Patient Module

Attribute Name	Tag	Source	Presence of Attribute	Presence of Value	Value	Conditions	Comments / Reference
Patient's Name	(0010,0010)	MWL; USER	ALWAYS	CONDITIONAL		Value empty if unidentified	Section 12
Patient ID	(0010,0020)	MWL; USER	ALWAYS	CONDITIONAL		Value empty if unidentified Patient	
Patient's Birth Date	(0010,0030)	MWL; USER	ALWAYS	CONDITIONAL		Value empty if unidentified	
Patient's Sex	(0010,0040)	MWL; USER	ALWAYS	CONDITIONAL		Value empty if unidentified	

Table 9-2. General Study Module

Attribute Name	Tag	Source	Presence of Attribute	Presence of Value	Value	Conditions	Comments / Reference
Study Instance UID	(0020,000D)	MWL; GENERATED	ALWAYS	ALWAYS			

Attribute Name	Tag	Source	Presence of Attribute	Presence of Value	Value	Conditions	Comments / Reference
Study Date	(0008,0020)	GENERATED	ALWAYS	ALWAYS	Current Date		
Study Time	(0008,0030)	GENERATED	ALWAYS	ALWAYS	Current Time		
Accession Number	(0008,0050)	MWL; USER; EMPTY	ALWAYS	ALWAYS		Value empty if undefined	Section 12
Referring Physician's Name	(0008,0090)	MWL;USER; EMPTY	ALWAYS	ALWAYS		Value empty if undefined	
Study Description	(0008,1030)	MWL;USER; EMPTY	ALWAYS	ALWAYS		Value empty if undefined	
Study ID	(0020,0010)	GENERATED	ALWAYS	ALWAYS			

Table 9-3. Patient Study Module

Attribute Name	Tag	Source	Presence of Attribute	Presence of Value	Value	Conditions	Comments
Patient's Age	(0010,1010)	MWL;USER;	ALWAYS	CONDITIONAL		Value empty if undefined	
Patient's Size	(0010,1020)	MWL;USER;	ALWAYS	CONDITIONAL		Value empty if undefined	Height
Patient's Weight	(0010,1030)	MWL;USER;	ALWAYS	CONDITIONAL		Value empty if undefined	
Additional Patient History	(0010,21B0)	USER;	EMPTY	CONDITIONAL		Value empty if undefined	

Table 9-3. General Series Module

Attribute Name	Tag	Source	Presence of Attribute	Presence of Value	Value	Conditions	Comments
Modality	(0008,0060)	<i>FIXED</i>	<i>ALWAYS</i>	<i>ALWAYS</i>	<i>CT</i>		
Series Instance UID	(0020,000E)	<i>GENERATED</i>	<i>ALWAYS</i>	<i>ALWAYS</i>			

Attribute Name	Tag	Source	Presence of Attribute	Presence of Value	Value	Conditions	Comments
...							

Table 9-4. Frame of Reference Module

Attribute Name	Tag	Source	Presence of Attribute	Presence of Value	Value	Conditions	Comments
...							

Table 9-5. General Equipment Module

Attribute Name	Tag	Source	Presence of Attribute	Presence of Value	Value	Conditions	Comments
...							

Table 9-6. Enhanced General Equipment Module

Attribute Name	Tag	Source	Presence of Attribute	Presence of Value	Value	Conditions	Comments

Table 9-7. General Image Module

Attribute Name	Tag	Source	Presence of Attribute	Presence of Value	Value	Conditions	Comments
...							

Table 9-8. Image Pixel Module

Attribute Name	Tag	Source	Presence of Attribute	Presence of Value	Value	Conditions	Comments
Photometric Interpretation	(0028,0004)	GENERATED	ALWAYS		See Section 9.1.4		
...							

Table 9-9. Multi-Frame Functional Groups Module

Attribute Name	Tag	Source	Presence of Attribute	Presence of Value	Value	Conditions	Comments
Shared Functional Groups Sequence	(5200,9229)						
Per-frame Functional Groups Sequence	(5200,9230)						
...							

Table 9-10. Multi-Frame Dimension Module

Attribute Name	Tag	Source	Presence of Attribute	Presence of Value	Value	Conditions	Comments
...							

Table 9-11. Acquisition Context Module

Attribute Name	Tag	Source	Presence of Attribute	Presence of Value	Value	Conditions	Comments
...							

Table 9-12. SOP Common Module

Attribute Name	Tag	Source	Presence of Attribute	Presence of Value	Value	Conditions	Comments
SOP Class UID	(008,0016)	GENERATED	ALWAYS	ALWAYS			Value matches SOP Class of generated object
SOP Instance UID	(0008,0018)	GENERATED	ALWAYS	ALWAYS			
Specific Character Set	(0008,0005)	CONFIGURATION	CONDITIONAL	ALWAYS	See Section 5.7	Required if any Character Set other than ISO_IR 100 is used	
...							
Private Data Element Characteristics Sequence	(0008,0300)	GENERATED	CONDITIONAL	CONDITIONAL	Only present in IODs that use private data elements	Used if IOD contains private Attributes	
>>...							

9.1.2 A.A.1.2 Common Functional Group Macros

The tables below list the Common Functional Group Macros that can either be used as part of the Shared Functional Groups Sequence (5200,9229) or as part of the Per-frame Functional Groups Sequence (5200,9230) of enhanced image IODs.

Table 9-13. Pixel Measures Functional Group Macro

Attribute Name	Tag	Source	Presence of Attribute	Presence of Value	Value	Conditions	Comments
<i>Pixel Measures Sequence</i>	(0028,9110)						
> <i>Pixel Spacing</i>	(0028,0030)						
> <i>Slice Thickness</i>	(0018,0050)						
> <i>Spacing Between Slices</i>	(0018,0088)						

Table 9-14. Frame Content Functional Group Macro

Attribute Name	Tag	Source	Presence of Attribute	Presence of Value	Value	Conditions	Comments
<i>Frame Content Sequence</i>	(0020,9111)						

Table 9-15. Plane Position (Patient) Functional Group Macro

Attribute Name	Tag	Source	Presence of Attribute	Presence of Value	Value	Conditions	Comments
<i>Plane Position Sequence</i>	(0020,9113)						

Table 9-16. Plane Orientation (Patient) Functional Group Macro

Attribute Name	Tag	Source	Presence of Attribute	Presence of Value	Value	Conditions	Comments
<i>Plane Orientation Sequence</i>	(0020,9116)						

Table 9-17. Referenced Image Functional Group Macro

Attribute Name	Tag	Source	Presence of Attribute	Presence of Value	Value	Conditions	Comments
<i>Referenced Image Sequence</i>	(0008,1140)						

Table 9-18. Frame Anatomy Functional Group Macro

Attribute Name	Tag	Source	Presence of Attribute	Presence of Value	Value	Conditions	Comments
<i>Frame Anatomy Sequence</i>	(0020,9071)						

Table 9-19. Irradiation Event Identification Functional Group Macro

Attribute Name	Tag	Source	Presence of Attribute	Presence of Value	Value	Conditions	Comments
<i>Irradiation Event Identification Sequence</i>	(0018,9477)						

9.1.3 A.A.1.3 Common Private Modules

The tables below list private Attributes that are used in multiple IODs generated by the system. For documentation convenience and readability, they are organized in modules, although the concept of modules does not exist in the standard for private Attributes.

Table 9-20. Private Module 1

Attribute Name	Tag	VR	VM	Identifiable Information	Source	Presence of Attribute	Presence of Value	Value	Conditions	Comments
Private Creator	(0009,00xx)	LO	1				ALWAYS	PRIVATEDATA1		
Private Attribute 1	(0009,xx01)	CS	1				ALWAYS	VALUE1		
Private Attribute 2	(0009,xx02)	IS	1-n	SAFE			CONDITIONAL	35127145	(0009,xx01) = VALUE1	

Table 9-21. Private Module 2

Attribute Name	Tag	VR	VM	Identifiable Information	Source	Presence of Attribute	Presence of Value	Value	Conditions	Comments
Private Creator	(0029,00xx)	LO	1					PRIVATEDATA2		
Private Attribute 3	(0029,xx01)	DT	1							
Private Attribute 4	(0029,xx02)	TM	1							

9.1.4 A.A.1.4 Coded Values

Table 9-22 lists Coded Values referenced from the "Value" column of the tables above.

Table 9-22. Values and Code Sets shared across IODs

Attribute Name	Tag	Value/Code	Condition	Comments
<i>Requesting Service Code Sequence</i>	(0032,1034)	(309915006, SCT, "Cardiology")		
		(309964003, SCT, "Radiology")		
<i>Photometric Interpretation</i>	(0028,0004)	MONOCHROME1	Grayscale Images	
		YBR_FULL_422	JPEG compressed Images	
		RGB	Uncompressed color images	

A.2 Computed Tomography Image IOD

Table 9-23. CT image IOD

IE	Module Name	Presence (Module)	Condition	Reference
Patient	Patient	ALWAYS		Table 9-1
Study	General Study	ALWAYS		Table 9-2
	Patient Study	ALWAYS		
Series	General Series	ALWAYS		Table 9-3
Frame Of Reference	Frame of Reference	ALWAYS		Table 9-4
Equipment	General Equipment	ALWAYS		Table 9-5
Image	General Image	ALWAYS		Table 9-7
	Image Plane	ALWAYS		Table 9-24
	CT Image	ALWAYS		Table 9-25
	Image Pixel	ALWAYS		Table 9-8
	SOP Common	ALWAYS		Table 9-12
	Contrast/Bolus	CONDITIONAL	if contrast media was used in this image	

IE	Module Name	Presence (Module)	Condition	Reference
	VOI LUT	ALWAYS		
Private	Private Module 1	CONDITIONAL	Present for Acquisition Protocol XXX	Table 9-20
	Private Module 2	ALWAYS		Table 9-21
	Private Module 3	ALWAYS		Table 9-26

9.2.1 A.A.2.1 <Image IOD 1> Specific Modules

The following tables list Modules and Attributes specific for <Image IOD 1>:

Table 9-24. Image Plane Module for <Image IOD 1>

Attribute Name	Tag	Source	Presence of Attribute	Presence of Value	Value	Conditions	Comments
<i>Pixel Spacing</i>	(0028,0030)	GENERATED					
<i>Image Orientation (Patient)</i>	(0020,0037)	GENERATED					
<i>Image Position (Patient)</i>	(0020,0032)	GENERATED					
<i>Slice Thickness</i>	(0018,0050)	GENERATED					

Table 9-25. CT Image Module for <Image IOD 1>

Attribute Name	Tag	Source	Presence of Attribute	Presence of Value	Value	Conditions	Comments
<i>Image Type</i>	(0008,0008)	GENERATED			See section A.2.4		
<i>Samples per Pixel</i>	(0028,0002)	GENERATED			1		
<i>Photometric Interpretation</i>	(0028,0004)	GENERATED			MONOCHROME2		

Attribute Name	Tag	Source	Presence of Attribute	Presence of Value	Value	Conditions	Comments
<i>Bits Allocated</i>	(0028,0100)	GENERATED			16		
<i>Bits Stored</i>	(0028,0101)	GENERATED			12		
<i>High Bit</i>	(0028,0102)	GENERATED			11		
<i>Rescale Intercept</i>	(0028,1052)	GENERATED			1024		
<i>Rescale Slope</i>	(0028,1053)	GENERATED					
<i>KVP</i>	(0018,0060)	GENERATED					
<i>Acquisition Number</i>	(0020,0012)	GENERATED					
<i>Exposure Time</i>	(0018,1150)	GENERATED					
<i>X-Ray Tube Current</i>	(0018,1151)	GENERATED					
<i>Exposure</i>	(0018,1152)	GENERATED					
<i>Anatomic Region Sequence</i>	(0008,2218)	GENERATED			See CID 4 "Anatomic Region"		

9.2.2 A.A.2.2 <Image IOD 1> Functional Group Macros (N/A)

N/A

9.2.3 A.A.2.3 <Image IOD 1> Private Modules

Table 9-26 lists private Modules and Attributes for <Image IOD 1>:

Table 9-26. Private Module3 for <Image IOD 1>

Attribute Name	Tag	VR	VM	Identifiable Information	Presence of Attribute	Presence of Value	Value	Conditions	Description
Private Creator	(0039,00xx)	LO	1			ALWAYS	PRIVATEDATA3		
Private Attribute 5	(0039,xx01)	CS	1	SAFE	ALWAYS	ALWAYS	VALUE1		
...									

9.2.4 A.A.2.3 <Image IOD 1> Coded Values

Table 9-27 lists Coded Values referenced from the "Value" column of the tables above for <Image IOD 1>:

Table 9-27. Values and Code Sets for <Image IOD 1>

Attribute Name	Tag	Value/Code	Condition	Comments
<i>Image Type</i>	(0008,0008)	<i>ORIGINAL</i>	<i>Value for Value 1</i>	
		<i>DERIVED</i>		
		<i>PRIMARY</i>	<i>Value for Value 2</i>	
		<i>SECONDARY</i>		
		<i>AXIAL</i>	<i>Value for Value 3</i>	
		<i>VMI</i>	<i>Value for Value 4</i>	
<i>ELECTRON_DENSITY</i>				
		...		

9.3 A.A.3 <image IOD 2 E.g., Enhanced Computed Tomography Image IOD>

Table 9-28 defines the structure of <Image IOD 2>.

Table 9-28. <Image IOD 2>

IE	Module Name	Presence (Module)	Condition	Reference
<i>Patient</i>	<i>Patient Module</i>	<i>ALWAYS</i>		<i>Table 9-1</i>
<i>Study</i>	<i>General Study Module</i>	<i>ALWAYS</i>		<i>Table 9-2</i>
<i>Series</i>	<i>General Series Module</i>	<i>ALWAYS</i>		<i>Table 9-3</i>
	<i>CT Series Module</i>	<i>ALWAYS</i>		<i>Table 9-30</i>
<i>Frame of Reference</i>	<i>Frame of Reference</i>	<i>ALWAYS</i>		<i>Table 9-4</i>
<i>Equipment</i>	<i>General Equipment Module</i>	<i>ALWAYS</i>		<i>Table 9-5</i>
	<i>Enhanced General Equipment</i>	<i>ALWAYS</i>		<i>Table 9-6</i>
<i>Image</i>	<i>Image Pixel</i>	<i>ALWAYS</i>		<i>Table 9-8</i>
	<i>Multi-Frame Functional Groups</i>	<i>ALWAYS</i>		<i>Table 9-9</i>
	<i>Multi-Frame Dimension</i>	<i>ALWAYS</i>		<i>Table 9-10</i>
	<i>Acquisition Context</i>	<i>ALWAYS</i>		<i>Table 9-11</i>
	<i>Enhanced CT Image</i>	<i>ALWAYS</i>		<i>Table 9-31</i>

IE	Module Name	Presence (Module)	Condition	Reference
	<i>SOP Common Module</i>	ALWAYS		<i>Table 9-12</i>

Table 9-29 lists the Functional group macros used in <Image IOD2>. The "Usage" column defines whether a Macro is used as a shared Macro, on a per frame base or whether depending on the acquisition context can be used in both contexts. The following Values are supported:

- PER_FRAME: The macro is used on a per frame basis, the Attributes are included in the Per-frame Functional Groups Sequence (5200,9230)
- SHARED: The macro is shared across all frames; the Attributes are included in the Shared Functional Groups Sequence (5200,9229)
- CONTEXT_DEPENDENT: Depending on the acquisition context the macro can either be used on a per frame basis or be shared across all frames.

Table 9-29. Functional Group Macros used in < Image IOD 2>

Functional Group Macro	Presence	Condition	Usage	Reference
<i>Pixel Measures</i>	ALWAYS		PER_FRAME	<i>Table 9-13</i>
<i>Frame Content</i>	ALWAYS		PER_FRAME	<i>Table 9-14</i>
<i>Plane Position (Patient)</i>	ALWAYS		SHARED	<i>Table 9-15</i>
<i>Frame Anatomy</i>	ALWAYS		CONTEXT_DEPENDENT	<i>Table 9-18</i>
<i>Irradiation Event Identification</i>	ALWAYS		PER_FRAME	<i>Table 9-19</i>
<i>CT Image Frame Type</i>	ALWAYS		PER_FRAME	<i>Table 9-32</i>
<i>CT Acquisition Type</i>	CONDITIONAL	<i>For images with Image Type (0008,0008) Value 1 as ORIGINAL or MIXED</i>	SHARED	<i>Table 9-33</i>
<i>CT Acquisition Details</i>	CONDITIONAL	<i>For images with Image Type (0008,0008) Value 1 as ORIGINAL or MIXED</i>	SHARED	<i>Table 9-34</i>
<i>CT Table Dynamics</i>	CONDITIONAL	<i>For images with Image Type (0008,0008) Value 1 as ORIGINAL or MIXED</i>	SHARED	<i>Table 9-35</i>
<i>CT Position</i>	CONDITIONAL	<i>For images with Image Type (0008,0008) Value 1 as ORIGINAL or MIXED</i>	SHARED	<i>Table 9-36</i>
<i>CT Geometry</i>	CONDITIONAL	<i>For images with Image Type (0008,0008) Value 1 as ORIGINAL or MIXED</i>	SHARED	<i>Table 9-37</i>

Functional Group Macro	Presence	Condition	Usage	Reference
<i>CT Reconstruction</i>	CONDITIONAL	For images with Image Type (0008,0008) Value 1 as ORIGINAL or MIXED	SHARED	Table 9-38.
<i>CT Exposure</i>	CONDITIONAL	For images with Image Type (0008,0008) Value 1 as ORIGINAL or MIXED	SHARED	Table 9-39
<i>CT X-Ray Details</i>	CONDITIONAL	For images with Image Type (0008,0008) Value 1 as ORIGINAL or MIXED	SHARED	Table 9-40
<i>CT Pixel Value Transformation</i>	ALWAYS		SHARED	Table 9-41
<i>CT Additional X-Ray Source</i>	CONDITIONAL	For systems with multiple X-Ray sources	SHARED	Table 9-42
<i>Multi-energy CT Characteristics</i>	CONDITIONAL	For systems with multiple X-Ray sources	SHARED	Table 9-43
..				

9.3.1 A.A.3.1 <Image IOD 2> Specific Modules

The following tables list Modules and Attributes specific for <Image IOD 2>:

Table 9-30. CT Series Module for <Image IOD 2>

Attribute Name	Tag	Source	Presence of Attribute	Presence of Value	Value	Conditions	Comments

Table 9-31. Enhanced CT Image Module for <Image IOD 2>

Attribute Name	Tag	Source	Presence of Attribute	Presence of Value	Value	Conditions	Comments

9.3.2 A.A.3.2 <Image IOD 2> Functional Group Macro

The tables below list functional group macros and Attributes for <Image IOD 2>:

Table 9-32. CT Frame Type Functional Group Macro for <Image IOD 2>

Attribute Name	Tag	Source	Presence of Attribute	Presence of Value	Value	Conditions	Comments
<i>CT Image Frame Type Sequence</i>	(0018,9329)						

Attribute Name	Tag	Source	Presence of Attribute	Presence of Value	Value	Conditions	Comments
...							

Table 9-33. CT Acquisition Type Functional Group Macro for <Image IOD 2>

Attribute Name	Tag	Source	Presence of Attribute	Presence of Value	Value	Conditions	Comments
<i>CT Acquisition Type Sequence</i>	(0018,9301)						

Table 9-34. CT Acquisition Details Functional Group Macro for <Image IOD 2>

Attribute Name	Tag	Source	Presence of Attribute	Presence of Value	Value	Conditions	Comments
<i>CT Acquisition Details Sequence</i>	(0018,9304)						

Table 9-35. CT Table Dynamics Functional Group Macro for <Image IOD 2>

Attribute Name	Tag	Source	Presence of Attribute	Presence of Value	Value	Conditions	Comments
<i>CT Table Dynamics Sequence</i>	(0018,9308)						

Table 9-36. CT Position Functional Group Macro for <Image IOD 2>

Attribute Name	Tag	Source	Presence of Attribute	Presence of Value	Value	Conditions	Comments
<i>CT Position Sequence</i>	(0018,9326)						

Table 9-37. CT Geometry Functional Group Macro for <Image IOD 2>

Attribute Name	Tag	Source	Presence of Attribute	Presence of Value	Value	Conditions	Comments
<i>CT Geometry Sequence</i>	(0018,9312)						

Table 9-38. CT Reconstruction Functional Group Macro for <Image IOD 2>

Attribute Name	Tag	Source	Presence of Attribute	Presence of Value	Value	Conditions	Comments
<i>CT Reconstruction Sequence</i>	(0018,9314)						

Table 9-39. CT Exposure Functional Group Macro for <Image IOD 2>

Attribute Name	Tag	Source	Presence of Attribute	Presence of Value	Value	Conditions	Comments
<i>CT Exposure Sequence</i>	(0018,9321)						

Table 9-40. CT X-Ray Details Functional Group Macro for <Image IOD 2>

Attribute Name	Tag	Source	Presence of Attribute	Presence of Value	Value	Conditions	Comments
<i>CT X-Ray Details Sequence</i>	(0018,9325)						

Table 9-41. CT Pixel Value Transformation Functional Group Macro for <Image IOD 2>

Attribute Name	Tag	Source	Presence of Attribute	Presence of Value	Value	Conditions	Comments
<i>Pixel Value Transformation Sequence</i>	(0028,9145)						

Table 9-42. CT Additional X-Ray Source Functional Group Macro for <Image IOD 2>

Attribute Name	Tag	Source	Presence of Attribute	Presence of Value	Value	Conditions	Comments
<i>CT Additional X-Ray Source Sequence</i>	(0018,9360)						

Table 9-43. CT Multi-energy CT Characteristics Functional Group Macro for <Image IOD 2>

Attribute Name	Tag	Source	Presence of Attribute	Presence of Value	Value	Conditions	Comments
<i>Multi-energy CT Processing Sequence</i>	(0018,9363)						

9.3.3 A.A.3.3 <Image IOD 2> Private Modules

9.3.4 A.A.3.4 <Image IOD 2> Coded Values

Table 9-44 lists Coded Values referenced from the "Value" column of the tables above for <Image IOD 2>:

Table 9-44. Values and Code Sets for <Image IOD 2>

Attribute Name	Tag	Value/Code	Condition	Comments

9.4 A.A.4. <SR IOD 1 E.g., Comprehensive SR IOD>

Table 9-45 defines the structure of <SR IOD 1>.

Table 9-45. <SR IOD 1>

IE	Module Name	Presence (Module)	Condition	Reference
<i>Patient</i>	<i>Patient Module</i>	<i>ALWAYS</i>		<i>Table 9-1</i>
<i>Study</i>	<i>General Study Module</i>	<i>ALWAYS</i>		<i>Table 9-2</i>
<i>Series</i>	<i>SR Document Series Module</i>	<i>ALWAYS</i>		<i>Table 9-47</i>
<i>Equipment</i>	<i>General Equipment Module</i>	<i>ALWAYS</i>		<i>Table 9-5</i>
<i>Document</i>	<i>SR Document General Module</i>	<i>ALWAYS</i>		<i>Table 9-47</i>
	<i>SR Document Content</i>	<i>ALWAYS</i>		<i>Table 9-48</i>
	<i>SOP Common Module</i>	<i>ALWAYS</i>		<i>Table 9-12</i>

9.4.1 A.A.4.1 <SR IOD 1> Specific Modules

The tables below list modules and Attributes used in <SR IOD1>:

Table 9-46. SR Document Series Module used in <SR IOD 1>

Attribute Name	Tag	Source	Presence of Attribute	Presence of Value	Value	Conditions	Comments
Modality	(0008,0060)	<i>FIXED</i>		<i>ALWAYS</i>	<i>SR</i>		
Referenced Performed Procedure Step Sequence	(0008,1111)	<i>GENERATED</i>	<i>ALWAYS</i>	<i>CONDITIONAL</i>	<i>(See Section 12 for details)</i>	<i>See Section 12</i>	
..							

Table 9-47. SR Document General Module used in <SR IOD 1>

Attribute Name	Tag	Source	Presence of Attribute	Presence of Value	Value	Conditions	Comments
Completion Flag	(0040,A491)	GENERATED	ALWAYS	ALWAYS	<<PARTIAL COMPLETE>>		
Verification Flag	(0040,A493)	GENERATED	ALWAYS	ALWAYS	<<UNVERIFIED VERIFIED>>		
Content Date	(0008,0023)	GENERATED	ALWAYS	ALWAYS	Current date		
Content Time	(0008,0033)	GENERATED	ALWAYS	ALWAYS	Current time		
Referenced Request Sequence	(0040,A370)	GENERATED	ALWAYS	CONDITIONAL	See Section 12	See Section 12	
...							

Table 9-48. SR Document Content Module used in <SR IOD 1>

Attribute Name	Tag	Source	Presence of Attribute	Presence of Value	Value	Conditions	Comments
Value Type	(0040,A040)	FIXED	ALWAYS	ALWAYS	CONTAINER		
Continuity of Content	(0040,A050)	FIXED	ALWAYS	ALWAYS	SEPARATE		
Content Template Sequence	(0040,A504)	GENERATED	ALWAYS	ALWAYS	See Section 10 for encoding on supported TIDs		

9.4.2 A.A.4.2 <SR IOD 1> Functional Group Macros (N/A)

N/A

9.4.3 A.A.4.3 <SR IOD 1> Private Modules

9.4.4 A.A.4.4 <SR IOD 1> Coded Values

Table 9-49 lists Coded Values referenced from the "Value" column of the tables above for <SR IOD1>:

Table 9-49. SR IOD 1>

Attribute Name	Tag	Value/Code	Condition	Comments

9.5 A.A.5 Basic Directory IOD

Table 9-50 defines the structure of the Basic Directory IOD.

Table 9-50. Basic Directory IOD

Attribute Name	Tag	Source	Presence of Attribute	Presence of Value	Value	Conditions	Comments
File Set Identification Module							
File-set ID	(0004,1130)	GENERATED					
Specific Character Set of File-set Descriptor File	(0004,1142)	GENERATED					
Directory Information Module							
Offset of the First Directory Record of the Root Directory Entity	(0004,1200)	GENERATED					
Offset of the Last Directory Record of the Root Directory Entity	(0004,1202)	GENERATED					
File-set Consistency Flag	(0004,1212)	GENERATED					
Directory Record Sequence	(0004,1220)	GENERATED					
>Offset of the Next Directory Record	(0004,1400)	GENERATED					
>Record In-use Flag	(0004,1410)	GENERATED					
>Offset of Referenced Lower-Level Directory Entity	(0004,1420)	GENERATED					
>Directory Record Type	(0004,1430)	GENERATED					
>Referenced File ID	(0004,1500)	GENERATED					
>Referenced SOP Class UID in File	(0004,1510)	SRC_INSTANCE					
>Referenced SOP Instance UID in File	(0004,1511)	SRC_INSTANCE					

Attribute Name	Tag	Source	Presence of Attribute	Presence of Value	Value	Conditions	Comments
>Referenced Transfer Syntax UID in File	(0004,1512)	SRC_INSTANCE					
Patient Keys							
>Specific Character Set	(0008,0005)	GENERATED					
>Patient's Name	(0010,0010)	SRC_INSTANCE					
>Patient ID	(0010,0020)	SRC_INSTANCE					
...							
Study Keys							
>Study Date	(0008,0020)	SRC_INSTANCE					
>Study Time	(0008,0030)	SRC_INSTANCE					
>Study Description	(0008,1030)	SRC_INSTANCE					
>Study Instance UID	(0020,000D)	SRC_INSTANCE					
>Study ID	(0020,0010)	SRC_INSTANCE					
>Accession Number	(0008,0050)	SRC_INSTANCE					
...							
Series Keys							
>Specific Character Set	(0008,0005)	GENERATED					
>Modality	(0008,0060)	SRC_INSTANCE					
>Series Instance UID	(0020,000E)	SRC_INSTANCE					
>Series Number	(0020,0011)	SRC_INSTANCE					
...							
Image Keys							
>Specific Character Set	(0008,0005)	GENERATED					

Attribute Name	Tag	Source	Presence of Attribute	Presence of Value	Value	Conditions	Comments
>Instance Number	(0020,0013)	SRC_INSTANCE					
>Samples per Pixel	(0028,0002)	SRC_INSTANCE					
>Photometric Interpretation	(0028,0004)	SRC_INSTANCE					
>Rows	(0028,0010)	SRC_INSTANCE					
>Columns	(0028,0011)	SRC_INSTANCE					
>Bits Allocated	(0028,0100)	SRC_INSTANCE					
>Bits Stored	(0028,0101)	SRC_INSTANCE					
>High Bit	(0028,0102)	SRC_INSTANCE					
>Pixel Representation	(0028,0103)	SRC_INSTANCE					
...							
SR Document Keys							
>Specific Character Set	(0008,0005)	GENERATED					
>Instance Number	(0020,0013)	SRC_INSTANCE					
>Completion Flag	(0040, A491)	SRC_INSTANCE					
>Verification Flag	(0040, A493)	SRC_INSTANCE					
>Content Date	(0008,0023)	SRC_INSTANCE					
>Content Time	(0008,0033)	SRC_INSTANCE					
>Verification DateTime	(0040,A030)	SRC_INSTANCE					
>Concept Name Code Sequence	(0040,A043)	SRC_INSTANCE					
>>Code Value	(0008,1000)						
>>Coding Scheme Designator	(0008,1002)						
>>Coding Scheme Version	(0008,1003)						

Attribute Name	Tag	Source	Presence of Attribute	Presence of Value	Value	Conditions	Comments
>>Code Meaning	(0008,1004)						

9.6 A.A.6 <Private IOD 1>

Table 9-51 defines the structure of <Private IOD 1>.

Table 9-51. <Private IOD 1>

IE	Module Name	Presence (Module)	Condition	Reference
<i>Patient</i>	<i>Patient Module</i>	ALWAYS		<i>Table 9-1</i>
<i>Study</i>	<i>General Study Module</i>	ALWAYS		<i>Table 9-2</i>
<i>Series</i>	<i>General Series Module</i>	ALWAYS		<i>Table 9-3</i>
<i>Frame of Reference</i>	<i>Frame of Reference</i>	ALWAYS		<i>Table 9-4</i>
<i>Equipment</i>	<i>General Equipment Module</i>	ALWAYS		<i>Table 9-5</i>
	<i>Private Module 1</i>	CONDITIONAL	<i>Present for Acquisition Protocol XXX</i>	<i>Table 9-20</i>
	<i>Private Module 2</i>	ALWAYS		<i>Table 9-21</i>
	<i>Private Module 4</i>	ALWAYS		<i>Table 9-52</i>
	<i>Private Module 5</i>	ALWAYS		<i>Table 9-54</i>
<i>Image</i>	<i>SOP Common Module</i>	ALWAYS		<i>Table 9-12</i>

9.6.1 A.A.6.1 <Private IOD 1> Specific Modules (N/A)

N/A

9.6.2 A.A.6.2 <Private IOD 1> Functional Group Macros

9.6.3 A.A.6.3 <Private IOD 1> Private Modules

The tables below list Private Modules and Attributes specific for <Private IOD 1>:

Table 9-52. Private Module 4 for <Private IOD 1>

Attribute Name	Tag	VR	VM	Identifiable Information	Source	Presence of Attribute	Presence of Value	Value	Condition	Description
Private Module 4										

Attribute Name	Tag	VR	VM	Identifiable Information	Source	Presence of Attribute	Presence of Value	Value	Condition	Description
Private Creator	(0035,00xx)	LO	1							
Private Attribute 6	(0035,xx01)	CS	1	SAFE				PRIVATECREATOR		
								TERM1		

Table 9-53. Private Module 5 for <Private IOD 1>

Attribute Name	Tag	VR	VM	Identifiable Information	Source	Presence of Attribute	Presence of Value	Value	Condition	Description
Private Module 5										
Private Creator	(0039,00yy)	LO	1					PRIVATECREATOR5		
Private Attribute 7	(0039,yy01)	CS	1	UN SAFE				See Table 9-54		

9.6.4 A.A.6.4 <Private IOD 1> Coded Values

Table 9-54 lists Coded Values referenced from the "Value" column of the tables above for <Private IOD 1>:

Table 9-54. Values and Code Sets for <Private IOD 1>

Attribute Name	Tag	Value/Code	Condition	Comments
Private Attribute 7	(0039,yy01)	TERM1	Color Image	
		TERM2	Grayscale Image	

10 A.B Structured Report Content Encoding

This section provides the detailed content encoding for all TIDs supported by *Scanner*.

Throughout the tables listed in Section 10 the following codes are used for the "Source" and "Presence of Content Item" columns.

In the "Source" column, the following Values can be used:

- FIXED: The Value is pre-defined and cannot be modified.
- GENERATED: The Value is generated by the system.

- CONFIGURATION: The Value is copied from the system configuratio
- MWL: The Value is copied from a Modality Worklist entry.
- QUERY: The Value is determined by performing a query of any of the supported Query/Retrieve Services.
- USER: The Value is entered by the user.
- SCANNED: The Value is read from a barcode scanner or similar device.
- EMPTY: The Attribute is sent with a zero-length Value.
- SRC_INSTANCE: The Value is copied from previously created/received SOP Instances.

In the "Presence of Content Item" the following Values can be used:

- ALWAYS: the module, functional group macro, Attributes or Value is always present.
- CONDITIONAL: the presence of the the module, functional group macro, Attributes or Value is dependent on a conditio The condition must be listed in the "Comments" colum
- SRC_COPY: The presence of the Attributes and Values depends on the availability of these in the source instances, which are used for copying this informatio
- EMPTY: The Attribute is present but without a Value (zero length).

10.1 A.B.1 Mammography CAD SR (TID 4000) N/A

Table 10-1 shows the encoding of content of a DICOM Mammography CAD SR (TID 4000).

Table 10-1. Mammography CAD SR (TID 4000)

NL	Rel with Parent	VT	Concept Name	Source	Presence of Content Item	Values	TID	Comments
		CONTAINER	(111036, DCM, "Mammography CAD Report")				4000	
>	HAS CONCEPT MOD	CODE	(121049, DCM, "Language of Content Item and Descendants")	CONFIGURATION		(en, RFC3066, "English")	1204	
>>	HAS CONCEPT MOD	CODE	(121046, DCM, "Country of Language")	CONFIGURATION		(US, ISO3166_1, "United States of America (the)")	1204	
>	CONTAINS	CONTAINER	(111028, DCM, "Image Library")				4020	
>>	CONTAINS	IMAGE					4020	

NL	Rel with Parent	VT	Concept Name	Source	Presence of Content Item	Values	TID	Comments
>>>	HAS ACQ CONTEXT	CODE	(111027, DCM, "Image Laterality")	SRC_INSTANCE		See CID 6023 "Side"	4020	
>>>	HAS ACQ CONTEXT	CODE	(111031, DCM, "Image View")	SRC_INSTANCE		See CID 4014 "View for Mammography"	4020	
>>>>	HAS CONCEPT MOD	CODE	(111032, DCM, "Image View Modifier")	SRC_INSTANCE		See Table 10-2	4020	
>>>	HAS ACQ CONTEXT	TEXT	(111044, DCM, "Patient Orientation Row")	SRC_INSTANCE			4020	
>>>	HAS ACQ CONTEXT	TEXT	(111043, DCM, "Patient Orientation Column")	SRC_INSTANCE			4020	
>>>	HAS ACQ CONTEXT	DATE	(111060, DCM, "Study Date")	SRC_INSTANCE			4020	
>>>	HAS ACQ CONTEXT	TIME	(111061, DCM, "Study Time")	SRC_INSTANCE			4020	
>>>	HAS ACQ CONTEXT	DATE	(111018, DCM, "Content Date")	SRC_INSTANCE			4020	
>>>	HAS ACQ CONTEXT	TIME	(111019, DCM, "Content Time")	SRC_INSTANCE			4020	
>>>	HAS ACQ CONTEXT	NUM	(111026, DCM, "Horizontal Pixel Spacing")	SRC_INSTANCE			4020	
>>>	HAS ACQ CONTEXT	NUM	(111066, DCM, "Vertical Pixel Spacing")	SRC_INSTANCE			4020	
>	CONTAINS	CODE	(111017, DCM, "CAD Processing and Findings Summary")	GENERATED		See CID 6047 "CAD and Processing Findings Summary"	4001	
>>	HAS PROPERTIES	TEXT	(111033, DCM, "Impression Description")	GENERATED		(Description, e.g., Breast density evaluation)	4002	

NL	Rel with Parent	VT	Concept Name	Source	Presence of Content Item	Values	TID	Comments
>>	HAS PROPERTIES	TEXT	(111001, DCM, "Algorithm Name")	GENERATED		(Algorithm Name, e.g., Breast Density Assessment)	4019	
>>	HAS PROPERTIES	TEXT	(111003, DCM, "Algorithm Version")	GENERATED		(Version, e.g., 1.1.1.1)	4019	
>>	HAS PROPERTIES	NUM	See CID 6142 Calculated Value	GENERATED			4002	
>>>	HAS CONCEPT MOD	CODE	(272741003, SCT, "Laterality")	GENERATED		See CID 6023 "Side"	4002	
>>>	HAS CONCEPT MOD	CODE	(121401, DCM, "Derivation")	GENERATED		See CID 6140 "Calculation Mehtod"	4002	
>>	INFERRED FROM	CONTAINER	(111034, DCM, "Individual Impression/ Recommendation")	GENERATED			4003	
>>>	HAS CONCEPT MOD	CODE	(111056, DCM, "Rendering Intent")	GENERATED		See CID 6034 "Intended Use of CAD Output"	4003	
>>>	CONTAINS	CODE	(111059, DCM, "Single Image Finding")	GENERATED		See Table 10-3	4006	
>>>>	HAS CONCEPT MOD	CODE	(111056, DCM, "Rendering Intent")	GENERATED		See CID 6034 "Intended Use of CAD Output"	4006	
>>>>	HAS PROPERTIES	TEXT	(111001, DCM, "Algorithm Name")	GENERATED			4019	
>>>>	HAS PROPERTIES	TEXT	(111003, DCM, "Algorithm Version")	GENERATED			4019	
>>>>	HAS PROPERTIES	SCOORD	(111010, DCM, "Center")	GENERATED			4021	
>>>>>	R-SELECTED FROM	IMAGE		GENERATED			4021	

NL	Rel with Parent	VT	Concept Name	Source	Presence of Content Item	Values	TID	Comments
>>>>	HAS PROPERTIES	SCoord	(111041, DCM, "Outline")	GENERATED			4021	
>>>>>	R-SELECTED FROM	IMAGE		GENERATED			4021	
>>>	CONTAINS	CODE	(111059, DCM, "Single Image Finding")	GENERATED		(129715009, SCT, "Breast Composition")	4006	
>>>>	HAS CONCEPT MOD	CODE	(111056, DCM, "Rendering Intent")	GENERATED		See CID 6034 "Intended Use of CAD Output"	4006	
>>>>	HAS PROPERTIES	TEXT	(111001, DCM, "Algorithm Name")	GENERATED			4019	
>>>>	HAS PROPERTIES	TEXT	(111003, DCM, "Algorithm Version")	GENERATED			4019	
>>>	HAS PROPERTIES	CODE	(SCT, 129715009, "Breast Composition")	GENERATED		See DCID 6000, "Overall Breast Composition"	4007	
>	CONTAINS	CODE	(111064, DCM, "Summary of Detections")	GENERATED		See CID 6042 "Status of Results"	4000	
>>	INFERRED FROM	CONTAINER	(111063, DCM, "Successful Detections")	GENERATED			4015	
>>>	CONTAINS	CODE	(111022, DCM, "Detection Performed")	GENERATED		See Table 10-3	4017	
>>>>	HAS PROPERTIES	TEXT	(111001, DCM, "Algorithm Name")	GENERATED			4019	
>>>>	HAS PROPERTIES	TEXT	(111003, DCM, "Algorithm Version")	GENERATED			4019	
>>>>>	R-SELECTED FROM	IMAGE		GENERATED			4021	

NL	Rel with Parent	VT	Concept Name	Source	Presence of Content Item	Values	TID	Comments
>	CONTAINS	CODE	(111065, DCM, "Summary of Analyses")	GENERATED		See DICID 6042, "Status of Results"	4000	
>>	INFERRED FROM	CONTAINER	(111062, DCM, "Successful Analyses")	GENERATED			4016	
>>>	CONTAINS	CODE	(111004, DCM, "Analysis Performed")			See CID 6043, "Types of Mammography CAD Analysis"	4018	
>>>>	HAS PROPERTIES	TEXT	(111001, DCM, "Algorithm Name")	GENERATED			4019	
>>>>	HAS PROPERTIES	TEXT	(111003, DCM, "Algorithm Version")	GENERATED			4019	
>>>>>	R-HAS PROPERTIES	IMAGE		GENERATED			4021	

10.1.1 A.B.1.1 Code Sets N/A

The following tables list specific code sets referenced from the Mammography CAD SR (TID 4000).

Table 10-2. Mammography CAD SR - Image View Modifier Codes

Coding Scheme Designator	Code Value	Code Meaning
SCT	399161006	Cleavage
SCT	399011000	Axillary Tail
SCT	399197002	Rolled Lateral
SCT	399226006	Rolled Medial
SCT	414493004	Rolled Inferior
SCT	415670009	Rolled Superior

Table 10-3. Mammography CAD SR - Single Image Finding Codes

Coding Scheme Designator	Code Value	Code Meaning
SCT	129793001	Mammography breast density
SCT	129770007	Individual Calcification
SCT	129769006	Calcification Cluster

10.2 A.B.2 Echocardiography Procedure Result SR (TID 5200) N/A

Table 10-4 shows the encoding of content of a DICOM Echocardiography Procedure Report (TID 5200).

Table 10-4. Echocardiography Procedure Report SR (TID 5200)

NL	Rel with Parent	VT	Concept Name	Source	Presence of Content Item	Values	TID	Comments
		CONTAINER	EV (125200, DCM, "Adult Echocardiography Procedure Report")				5200	
>	HAS CONCEPT MOD	CODE	(121049, DCM, "Language of Content Item and Descendants")	CONFIGURATION		(en, RFC3066, "English")	1204	
>>	HAS CONCEPT MOD	CODE	(121046, DCM, "Country of Language")	CONFIGURATION		(US, ISO3166_1, "United States of America (the) ")	1204	
>	HAS OBS CONTEXT	CODE	(121005, DCM, "Observer Type")	GENERATED		(121006, DCM, "Person")	1002	
>	HAS OBS CONTEXT	PNAME	EV (121008, DCM, "Person Observer Name")	CONFIGURATION			1003	
>	CONTAINS	CONTAINER	EV (121118, DCM, "Patient Characteristics")	GENERATED			5201	
>>	CONTAINS	NUM	(121118, DCM, "Subject Age")	GENERATED			5201	Calculated from Date of Birth
>>	CONTAINS	CODE	EV (121032, DCM, "Subject Sex")	MWL		See CID 7455 "Sex"	5201	

NL	Rel with Parent	VT	Concept Name	Source	Presence of Content Item	Values	TID	Comments
>>	CONTAINS	NUM	(8277-6, LN, "Body Surface Area")	GENERATED			5201	
>>>	INFERED FROM	CODE	(8278-4, LN, "Body Surface Area Formula")	GENERATED		See CID 3663 "Body Surface Area Equations"	5201	
>	CONTAINS	CONTAINER	(59776-5, LN, "Findings")	GENERATED		One Container for each supported Finding Site, see Section 10.2.1	5202	

The following rows are supported for all Finding Sites listed in Section 10.2.1. Values for supported concepts are listed in the "Modifier" column of the Tables in the respective subsections of Section 10.2.1.

>>	HAS CONCEPT MOD	CODE	(363698007, SCT "Finding Site")	GENERATED		See TID 5200 for supported Finding Sites	5202	
>>	CONTAINS	CONTAINER	(125007, DCM, "Measurement Group")				5202	
>>>	CONTAINS	NUM	See Section 10.2.1 for measurements and supported Modifiers for each Finding Site				300	
>>>>	HAS CONCEPT MOD	CODE	(370129005, SCT, "Measurement Method")	GENERATED		See CID 12227 "Echocardiography Measurement Method"	300	
>>>>	HAS CONCEPT MOD	CODE	(363698007, SCT, "Finding Site")	GENERATED		See CID 12236 "Echo Anatomic Sites"	300	
>>>>	HAS CONCEPT MOD	CODE	(26067400, SCT, "Flow Direction")	GENERATED		See CID 12221 "Flow Direction"	5203	
>>>>	HAS CONCEPT MOD	CODE	(272517003, SCT, "Respiratory Cycle Point")	GENERATED		See CID 12234 "Respiration State"	5203	
>>>>	HAS CONCEPT MOD	CODE	(272518008, SCT, "Cardiac Cycle Point")	GENERATED		See CID 12233 "Cardiac Phase"	5203	

NL	Rel with Parent	VT	Concept Name	Source	Presence of Content Item	Values	TID	Comments
>>>>	HAS CONCEPT MOD	CODE	(399264008, SCT, "Image Mode")	GENERATED		See CID 12224 "Ultrasound Image Modes"	5203	
>>>>	HAS CONCEPT MOD	CODE	(111031, DCM, "Image View")	GENERATED		See CID 12002 "Ultrasound Protocol Stage Types"	5203	

10.2.1 A.B.2.1 Measurement Encoding

The following Sections provide a list of measurements encoded for each Finding Site.

Details about the supported measurements can be found at [<link to external document>](#).

10.2.1.1 A.B.2.1.1 Left Ventricle

Table 10-5 lists the measurements supported by Scanner. The first column lists the label that is used on [<products reporting screen>](#) to select the respective measurements.

Table 10-5. Left Ventricle Measurements

Label	Measurement	Modifier		Unit
<i>Echo Section (TID 5202) - Left Ventricle, (363698007, SCT, "Finding Site") : (87878005, SCT, " Left Ventricle")</i>				
LV CI A2C MOD	(54993008, "SCT, Cardiac Index")	(399264008, SCT, "Image Mode")	(399064001, SCT, "2D mode")	(l/min/m2, UCUM, "l/min/m2")
		(111031, DCM, "Image View")	(399232001, SCT, "Apical two chamber")	
		(370129005, SCT, "Measurement Method")	(125208, DCM, "Method of Disks, Single Plane")	
LVID d PSAX A-P	(LVID_AP, 99VENDOR_X, Left Ventricle Internal Dimension A-P")	(272518008, SCT, "Cardiac Cycle Point")	(90892000, SCT, "Diastole")	(l/min/m2, UCUM, "l/min/m2")
		(111031, DCM, "Image View")	(399271003, SCT, "Parasternal short axis at the Papillary Muscle level")	
		(399264008, SCT, "Image Mode")	(399064001, SCT, "2D mode")	
...				

10.2.1.2 A.B.2.1.2 Right Ventricle

Table 10-6 list the measurements supported by Scanner. The first column lists the label that is used on <products reporting screen>to select the respective measurements.

Table 10-6. Right Ventricle Measurements

Label	Measurement	Modifier		Unit
<i>Echo Section (TID 5202) - Right Ventricle, (363698007, SCT, "Finding Site") : (53085002, SCT, "Right Ventricle")</i>				
RV Area s A4C	(42798000, SCT "Area")	(272518008, SCT, "Cardiac Cycle Point")	(111973004, SCT, "Systole")	(cm2/m2, UCUM, "cm2/m2")
		(111031, DCM, "Image View")	(399214001, SCT "Apical four chamber")	
		(399264008, SCT, "Image Mode")	(399064001, SCT, "2D mode")	
		(370129005, SCT, "Measurement Method")	(125208, DCM, "Method of Disks, Single Plane")	
...				

11 A.C Security Details

This section provides additional details about security features that are formally described in Section 8.

11.1 A.C.1 External Network Requirement Details

11.1.1 A.C.1.1 Basic Time Synchronization

11.1.2 A.C.1.2 Basic Network Address Management

11.1.3 A.C.1.3 Application Configuration Management

Table 11-1 defines the security patterns supported :

Table 11-1. LDAP Security Patterns

Actor	LDAP Security Pattern	Supported	Comments
LDAP Server	TLS		
	TLS-Manual		
	Basic		
	Basic-Manual		
	Anonymous		

Actor	LDAP Security Pattern	Supported	Comments
	Anonymous-Manual		
	[Additional pattern]		
LDAP Client	TLS		
	TLS-Manual		
	Basic		
	Basic-Manual		
	Anonymous		
	Anonymous-Manual		
	[Additional pattern]		

11.1.4 A.C.1.4 DNS Service Discovery (N/A)

11.2 A.C.2 DICOM Security Profile Details

11.2.1 A.C.2.1 Online Electronic Storage Secure Use

11.2.2 A.C.2.2 Audit Trail Messages

Table 11-2 specifies the DICOM Audit Messages that *Scanner* can detect and report. It defines the list of triggers that will cause the Audit Message to be generated and if these triggers can be configured or not. It also specifies whether the content of the Audit Message can be configured or not.

Table 11-2. DICOM Specific Audit Messages

Audit Message	Used	Supported Triggers	Configurable Triggers	Configurable Message	Comments
<i>Application Activity</i>					
<i>Audit Log Used</i>					
<i>Begin Transferring DICOM Instances</i>					
<i>Data Export</i>					
<i>Data Import</i>					
<i>DICOM Instance Accessed</i>					
<i>DICOM Instance Transferred</i>					

Audit Message	Used	Supported Triggers	Configurable Triggers	Configurable Message	Comments
<i>DICOM Study Deleted</i>					
<i>Network Entry</i>					
<i>Query</i>					
<i>Security Alert</i>					
<i>User Autdentication</i>					
<i>Order Record</i>					
<i>Patient Record</i>					
<i>Procedure Record</i>					

Table 11-3 specifies the implementation details of each audit message supported by this product.

Table 11-3. Audit Message Details

Real-World Entities	Field Name	Supported	Value Constraints
Application Activity Message			
<i>Event</i>	<i>EventID</i>		<i>EV (110100, DCM, "Application Activity")</i>
	<i>EventActionCode</i>		
	<i>EventDateTime</i>		
	<i>EventOutcomeIndicator</i>		
	<i>EventTypeCode</i>		
<i>Active Participant: Application started (1)</i>	<i>UserID</i>		
	<i>AlternativeUserID</i>		
	<i>UserName</i>		
	...		
...
<i>[Any extension]</i>
Audit Log Used Message			
...

<i>Real-World Entities</i>	<i>Field Name</i>	<i>Supported</i>	<i>Value Constraints</i>
...			
<i>[Other message]</i>			

11.2.3 A.C.2.3 Audit Trail Message Transmission Profile - SYSLOG - TLS

See Section 6.6 Audit Trail Syslog Configuration for information about Syslog-TLS parameters.

11.2.4 A.C.2.4 Audit Trail Message Transmission Profile - SYSLOG - UDP

See Section 6.6 Audit Trail Syslog Configuration for information about Syslog-UDP parameters.

11.2.5 A.C.2.5 Secure Transport Connection Details

Table 11.2.5-1 lists the secure transport connection profiles and cipher suites supported for TLS 1.3:

Table 11.2.5-1. Secure Transport Connection Profiles and Cipher Suites

Profile	Cipher Suite	Default Preference Order (from 1=preferred to n=less preferred)
Modified BCP 195 RFC 8996 TLS Secure Transport Connection Profile	TLS_AES_256_GCM_SHA384	
	TLS_CHACHA20_POLY1305_SHA256	
	TLS_AES_128_GCM_SHA256	
	TLS_AES_128_GCM_SHA256	
	TLS_AES_128_GCM_SHA256	
	TLS_AES_128_CCM_8_SHA256	
<i>[Any TLS Profile supported by Scanner]</i>	<i>[Any Cypher suite]</i>	

Table 11.2.5-2 lists the secure transport connection profiles and key exchange algorithms supported for TLS 1.3:

Table 11.2.5-2. Secure Transport Connection Profiles and TLS 1.3 Key Exchange Algorithms

Profile	Cipher Suite	Default Preference Order (from 1=preferred to n=less preferred)
Modified BCP 195 RFC 8996 TLS Secure Transport Connection Profile	ECDHE	
	DHE	
<i>[Any TLS Profile supported by Scanner]</i>	<i>[Any key exchange algorithm]</i>	

Table 11.2.5-3 lists the secure transport connection profiles and signature algorithms supported for TLS 1.3:

Table 11.2.5-3. Secure Transport Connection Profiles and TLS 1.3 Signature Algorithms

Profile	Cipher Suite	Default Preference Order (from 1=preferred to n=less preferred)
Modified BCP 195 RFC 8996 TLS Secure Transport Connection Profile	ECDSA	
	RSASSA PKCS#1 v1.5 (RSA)	
	RSASSA-PSS	
<i>[Any TLS Profile supported by Scanner]</i>	<i>[Any signature algorithm]</i>	

Table 11-4 lists the secure transport connection profiles and cipher suites supported for TLS 1.2:

Table 11-4. Secure Transport Connection Profiles and Cipher Suites

Profile	Cipher Suite	Default Preference Order (from 1=preferred to n=less preferred)
<i>Modified BCP 195 RFC 8996 TLS Secure Transport Connection Profile</i>	<i>TLS_ECDHE_ECDSA_WITH_AES_256_GCM_SHA384</i>	
	<i>TLS_ECDHE_RSA_WITH_AES_256_GCM_SHA384</i>	
	<i>TLS_ECDHE_ECDSA_WITH_CAMELLIA_256_GCM_SHA384</i>	
	<i>TLS_ECDHE_RSA_WITH_CAMELLIA_256_GCM_SHA384</i>	
	<i>TLS_ECDHE_ECDSA_WITH_AES_256_CCM</i>	
	<i>TLS_ECDHE_ECDSA_WITH_AES_256_CCM_8</i>	
	<i>TLS_ECDHE_ECDSA_WITH_CHACHA20_POLY1305_SHA256</i>	
	<i>TLS_ECDHE_RSA_WITH_CHACHA20_POLY1305_SHA256</i>	
	<i>TLS_ECDHE_RSA_WITH_AES_128_GCM_SHA256</i>	
	<i>TLS_ECDHE_RSA_WITH_AES_128_GCM_SHA256</i>	
	<i>TLS_ECDHE_ECDSA_WITH_CAMELLIA_128_GCM_SHA256</i>	
	<i>TLS_ECDHE_RSA_WITH_CAMELLIA_128_GCM_SHA256</i>	
	<i>TLS_ECDHE_RSA_WITH_CAMELLIA_128_GCM_SHA256</i>	
	<i>TLS_ECDHE_ECDSA_WITH_AES_128_CCM_8</i>	

Profile	Cipher Suite	Default Preference Order (from 1=preferred to n=less preferred)
	[Other Cipher Suites]	

Table 11-5 describes the configurable parameters and behaviors supported by this product for the Secure Transport Connection:

Table 11-5. Secure Transport Connection Configuration

Local Secure Transport Connection Configuration			
Parameter/Behavior	Configurable	Default Value	Comments
Common Secure Transport Connection parameters			
Port	See Section 6 Configuration		
A-P-ABORT provider reason in case of integrity check failure			
...	...		
BCP 195 RFC 8996 TLS Secure Transport Connection			
[List specific configurable parameters for the local system]			
Modified BCP 195 RFC 8996 TLS Secure Transport Connection Parameters			
[List specific configurable parameters for the local system]			
Other Profile Secure Transport Connection parameters			
Remote Secure Transport Connection Configuration Parameters			
Parameter	Configurable	Default Value	Comments
Common Secure Transport Connection Parameters			
Port	See Section 6 Configuration		
A-P-ABORT provider reason in case of integrity check failure			
...	...		
BCP 195 RFC 8996 TLS Secure Transport Connection			

Local Secure Transport Connection Configuration			
Parameter/Behavior	Configurable	Default Value	Comments
<i>[List specific configurable parameters for the local system]</i>			
Modified BCP 195 RFC 8996 TLS Secure Transport Connection Parameters			
<i>[List specific configurable parameters for the local system]</i>			
<Other Profile> Secure Transport Connection Parameters			

11.2.6 A.C.2.6 Attribute Confidentiality Details

Table 11-6 provides the list of Attributes and the action when de-identifying instances. Supported Action Codes are defined in PS 3.15 Section E.1.

Table 11-6. De-identified Elements and Actions

Attribute Name	Tag	Action	Encrypted	Comments
<i>Basic Profile Option</i>				
<Element name>	<(xxxx,yyyy) >			<i>[In case of dummy Value, describe here the algorithm that produces the Value]</i>
<i>[Additional Private Option]</i>				

Also mention if Encrypted Attributes Data Set is to be used and which Transfer Syntaxes are supported for encoding/decoding the Encrypted Attributes Data Set.

11.2.7 A.C.2.7 Digital Signature Details (N/A)

11.2.8 A.C.2.8 Additional DICOM Security Profile Details (N/A)

12 A.D Mapping of Attributes (N/A)

12.1 A.D.1 Mapping Between Modality Worklist Instances and MPPS (N/A)

13 A.E Code Set Usage

